



BOCCOLE
BUSHINGS



CATALOGO TECNICO GENERALE
GENERAL TECHNICAL CATALOGUE
isb-industries.com





I N D U S T R I E S



Headquarter **ITALCUSCINETTI S.p.A. a Socio Unico** - C.F. e P.I. CEE IT 00966080350

Via Caponnetto, 15 - 42048 Rubiera (Reggio Emilia) ITALIA - R.E.A. C.C.I.A.A. RE 153325 - Capitale Sociale € 1.000.000 i.v - info@isb-industries.com

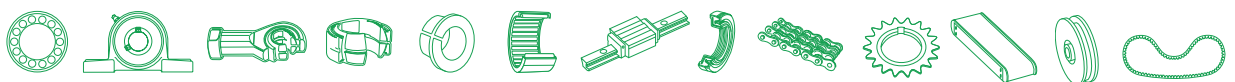

isb-industries.com

PROGRAMMA GENERALE DI VENDITA

GENERAL SALES PROGRAM



Cuscinetti e componenti
Bearings and components



Cuscinetti a rullini
Needle bearings

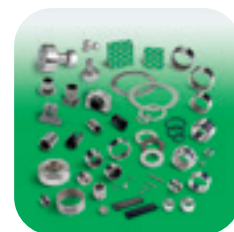

Supporti autoallineanti
Self-aligning bearing units



**Snodi sferici
teste a snodo - forcelle**
*Spherical plain bearings
rod ends - clevises*



Boccole
Bushings



Ruote libere
Free wheels

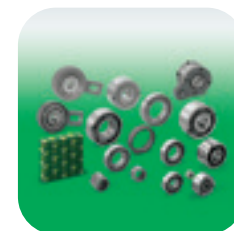

**Cuscinetti Micro /
Applicazioni silenziose**
*Micro bearings /
Low noise application*



Cuscinetti di grandi dimensioni
Large bearings



Cuscinetti a sfere polimerici
Polymeric ball bearings



Cuscinetti di precisione
Precision bearings

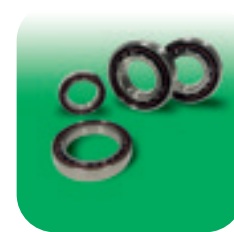

**Componenti per la
movimentazione lineare**
Components for linear motion



Cuscinetti di base
Slewing bearings





Distributore / Distributor



Distribuido por:







ISB[®] WORLD



PLANTS  

BRANCHES 

REPRESENTATIVE OFFICE 

DISTRIBUTORI in oltre 90 paesi nel mondo

60+ ISB SERVICES

2000+ DISTRIBUTORI e PUNTI VENDITA

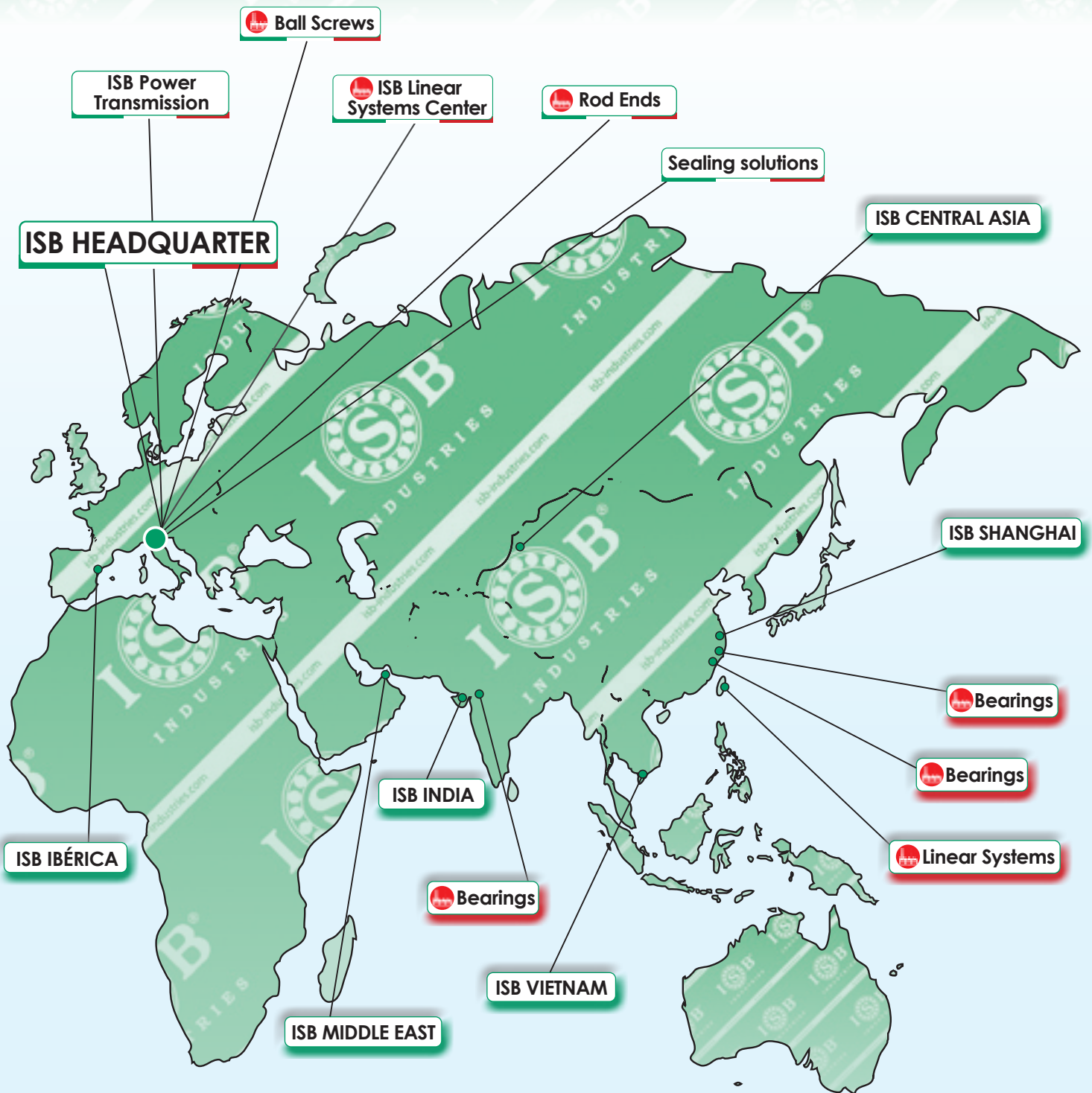

DISTRIBUTORS in over 90 countries in the world

60+ ISB SERVICES

2000+ DISTRIBUTORS and SALES POINTS

PRODUZIONE PRODUCTION

Tutti i prodotti **ISB**® sono costruiti esclusivamente da aziende con Sistema Qualità certificato secondo le norme UNI EN ISO 9001

All products **ISB**® are manufactured exclusively by companies with UNI EN ISO 9001 certified Quality System.



Suministros Industriales y Servicios



... un'ulteriore serie di controlli vengono eseguiti da laboratori esterni specializzati, attrezzati con moderne strumentazioni.

... an additional series of tests are conducted by specialised third party Laboratories using the latest instruments.



CONTROLLO QUALITÀ QUALITY CONTROL

... centro di controllo qualità dell'HQ con uno staff di Ingegneri tecnici al vostro servizio.

... a quality control centre in the HQ with a staff of technical engineers at your service.

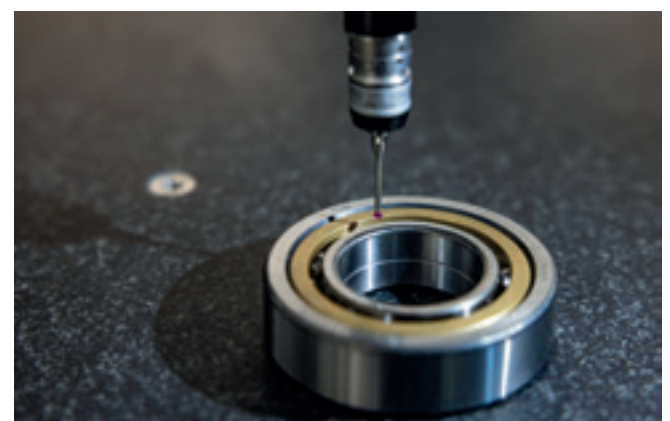

APPLICAZIONI APPLICATIONS

AGRICOLTURA
CASA
INDUSTRIA
MACCHINARI
TEMPO LIBERO
UFFICIO
VEICOLI

AGRICULTURE
HOME
INDUSTRY
MACHINERIES
FREE TIME
OFFICE
VEHICLES

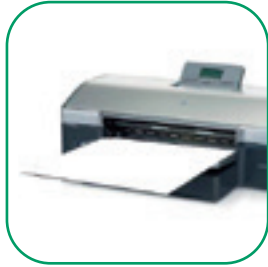

mayoral

Suministros Industriales y Servicios

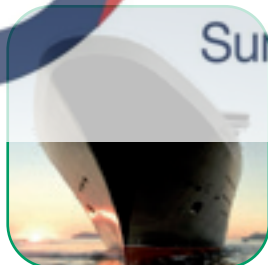

Le numerose linee di cuscinetti e componenti **ISB®** consentono, di soddisfare le esigenze nei più svariati settori applicativi. L'ampia gamma e la qualità dei prodotti è tale da garantire applicazioni anche in condizioni d'impiego gravose. I cuscinetti e componenti **ISB®**, vantano una produzione articolata e completa di tutte le tipologie, indicata pertanto a soddisfare le più svariate esigenze applicative.

*The diverse product lines of **ISB®** bearings and components, make it possible to satisfy the needs of a wide variety of fields of application. The wide range and quality of products is also a guarantee for heavy duty applications. **ISB®** bearings and components are available in versions across-the-board and can meet the requirements of a wide variety of demanding applications.*



L'assoluta qualità di una gamma senza eguali
The absolute quality of a peerless range

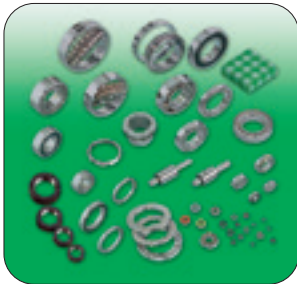

CUSCINETTI E COMPONENTI
 Bearings and components

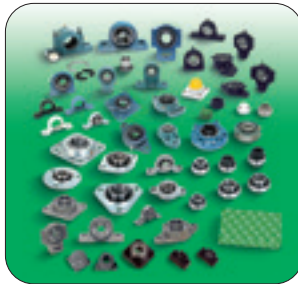

SUPPORTI AUTOALLINEANTI
 Self-aligning bearing units



SNODI SFERICI, TESTE A SNODO,
 FORCELLE - Spherical plain
 bearings, Rod ends, Clevises



BOCCOLE
 Bushings

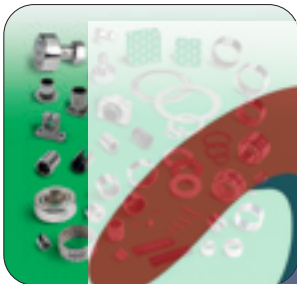

CUSCINETTI A RULLINI
 Needle bearings



CUSCINETTI DI BASE
 Slewing bearings



CUSCINETTI PER APPLICAZIONI
 A BASSA RUMOROSITÀ
 Bearings for low noise applications



RUOTE LIBERE
 Free wheels



CUSCINETTI A SFERE
 IN MATERIALI POLIMERICI
 Polymeric ball bearings



CUSCINETTI BONDERIZZATI
 High temperature bearings



SFERE PORTANTI - SFERE DI PRECISIONE
 RULLI E RULLINI DI PRECISIONE
 Ball transfer units - Precision balls
 Precision rollers and needles



ANELLI KOPRO
 KOPRO Rings



PRODOTTI IN ACCIAIO INOX
 INOX products



SISTEMI LINEARI
 Linear systems



GUARNIZIONI INDUSTRIALI
 Industrial Seals

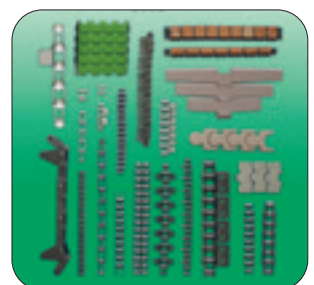

CATENE
 Chains



ISB® marchio sinonimo di qualità

ISB è una consolidata realtà nella produzione e distribuzione nel mondo della componentistica industriale. Una **vasta gamma** di prodotti di **alta qualità** sempre disponibili a magazzino e con un **servizio** di consegna just in time. Tre quindi sono i fattori combinati in un unico brand, una formula che proietta ISB tra i leader di mercato e che risponde pienamente alle esigenze tecniche e commerciali dei migliori punti di distribuzione, delle grandi case costruttrici e delle grandi manutenzioni.

La produzione abbraccia tutto il settore delle boccole; per boccole con caratteristiche tecniche e costruttive particolari è a disposizione un ufficio tecnico in grado di offrire al cliente un supporto di application-engineering. Questo catalogo ha il compito di aiutare ed accompagnare i progettisti di macchine ed equipaggiamenti, fornendo loro un valido contributo nella ricerca delle soluzioni ottimali di impiego delle boccole illustrandone le caratteristiche tecniche, dimensionali, applicative e qualitative. Ogni sezione del catalogo, dedicata ad una specifica tipologia di boccola, comprende un'introduzione che illustra le caratteristiche tecniche della tipologia di prodotto, con le tolleranze dimensionali e le altre informazioni tecniche necessarie alla scelta del tipo di boccola da utilizzare. La seconda parte della sezione include le tabelle dei prodotti disponibili a programma, che sono organizzate in funzione del diametro del foro. Tutte le caratteristiche tecniche costruttive sono standardizzate in accordo alle norme ISO di riferimento, al fine di fornire un prodotto intercambiabile e normato.

Tutti i prodotti ISB® sono costruiti nel rispetto della normativa RoHS.

ISB® is a trademark which identifies quality

*ISB is a leading manufacturer and distributor in the world of industrial components. We offer a **huge range of high-quality products** that are always available in stock and a just in time delivery **service**. There are thus three factors combined in a single brand, a formula that has made ISB a market leader and that fully meets technical and commercial needs of the best distribution points, major industrial manufacturers and important maintenance projects.*

The production includes all bushings, for bushings with particular technical and construction characteristics, a technical office is available to offer our clients application-engineering support. This catalogue has the purpose of helping the designers of machines and equipment, providing them with a valid contribution in the search for optimal solutions for the use of bushings by illustrating their technical, dimensional, applicative and qualitative characteristics. Each section of the catalogue, dedicated to a specific type of bushing, includes an introduction that illustrates the technical characteristics of the product type, with the dimensional tolerances and other technical information, necessary to choose the type of bushing to be used. The second part of the section includes the tables of the available products that are organized according to the bore diameter. All the technical construction characteristics are standardized in accordance with the related ISO standards, in order to provide an interchangeable product, and standardized.

All ISB® products are produced according to RoHS regulation.

CAPITOLO 1.		CHAPTER 1.	
1.	Caratteristiche boccole SF-1..... pag. 1	1.	SF-1 bushings characteristics..... pag. 1
1.1	Caratteristiche e funzionalità..... pag. 1	1.1	Functionality and characteristics..... pag. 1
1.2	Utilizzo..... pag. 2	1.2	Use..... pag. 2
1.3	Capacità di carico..... pag. 3	1.3	Load capacity..... pag. 3
1.4	Fluidi lubrificanti..... pag. 4	1.4	Lubricants fluids..... pag. 4
1.5	Temperatura..... pag. 4	1.5	Temperature..... pag. 4
	Tabella dimensionali e tolleranze..... pag. 5		Tolerances and dimensions tables..... pag. 5
CAPITOLO 2.		CHAPTER 2.	
2.	Caratteristiche boccole SF-2..... pag. 21	2.	SF-2 bushings characteristics..... pag. 21
2.1	Struttura SF-2..... pag. 21	2.1	SF-2 structure..... pag. 21
2.2	Caratteristiche tecniche..... pag. 22	2.2	Technical features..... pag. 22
2.3	Prova di durata..... pag. 22	2.3	Durability test..... pag. 22
	Tabella dimensionali e tolleranze..... pag. 23		Tolerances and dimensions tables..... pag. 23
CAPITOLO 3.		CHAPTER 3.	
3.	Caratteristiche boccole sinterizzate BNZ e FE..... pag. 35	3.	BNZ and FE sintered bushings characteristics..... pag. 35
3.1	Materiale..... pag. 35	3.1	Material..... pag. 35
	Tabella dimensionali e tolleranze..... pag. 36		Tolerances and dimensions tables..... pag. 36
CAPITOLO 4.		CHAPTER 4.	
4.	Caratteristiche boccole in bronzo 090 e 092..... pag. 49	4.	090 and 092 bronze bushings characteristics..... pag. 49
4.1	Caratteristiche tecniche..... pag. 50	4.1	Technical features..... pag. 50
4.2	Lubrificazione..... pag. 50	4.2	Lubrication..... pag. 50
	Tabella dimensionali e tolleranze..... pag. 51		Tolerances and dimensions tables..... pag. 51
CAPITOLO 5.		CHAPTER 5.	
5.	Caratteristiche boccole bimetalliche BM..... pag. 57	5.	BM bimetal bushings characteristics..... pag. 57
5.1	Caratteristiche tecniche..... pag. 58	5.1	Technical features..... pag. 58
5.2	Specifica dei materiali..... pag. 59	5.2	Material specifications..... pag. 59
	Tabella dimensionali e tolleranze..... pag. 60		Tolerances and dimensions tables..... pag. 60
CAPITOLO 6.		CHAPTER 6.	
6.	Caratteristiche boccole con lubrificante solido BG..... pag. 67	6.	BG bushings with solid lubricant characteristics..... pag. 67
6.1	Caratteristiche tecniche..... pag. 67	6.1	Technical features..... pag. 67
6.2	Specifica dei materiali..... pag. 68	6.2	Material specifications..... pag. 68
	Tabella dimensionali e tolleranze..... pag. 69		Tolerances and dimensions tables..... pag. 69
CAPITOLO 7.		CHAPTER 7.	
7.	Caratteristiche boccole con sfere ingabbiate BSI (allineate o a spirale)..... pag. 89	7.	BSI ball retainer bushings characteristics (spiral or straight line array)..... pag. 89
7.1	Caratteristiche tecniche..... pag. 89	7.1	Technical features..... pag. 89
7.2	Tolleranze..... pag. 89	7.2	Tolerances..... pag. 89
CAPITOLO 8.		CHAPTER 8.	
8.	Programma generale di vendita ISB®..... pag. 93	8.	ISB® general sales program..... pag. 93
CAPITOLO 9.		CHAPTER 9.	
9.	Tabella d'intercambiabilità..... pag. 97	9.	Interchangeability table..... pag. 97
CAPITOLO 10.		CHAPTER 10.	
10.	Tabella di conversione pollici/millimetri..... pag. 99	10.	Inches/millimetres conversion table..... pag. 99



Foto prodotto Product photo	Tipo Type	Dimensioni Dimensions	Pagina Page
	Boccole SF-1 Rivestimento in bronzo - Misure metriche <i>SF-1 Bushings</i> Bronze covering - Metric sizes Su richiesta disponibili in altre esecuzioni (vedi pag. 93) Under request, available also in other execution (see page. 93)	2 - 445	6
	Boccole flangiate SF-1 F Rivestimento in bronzo - Misure metriche <i>SF-1 F Flanged bushings</i> Bronze covering - Metric sizes Su richiesta disponibili in altre esecuzioni (vedi pag. 93) Under request, available also in other execution (see page. 93)	3 - 120	9
	Ralle WC SF-1 Rivestimento in bronzo - Misure metriche <i>WC SF-1 Thrust washers</i> Bronze covering - Metric sizes Su richiesta disponibili in altre esecuzioni (vedi pag. 93) Under request, available also in other execution (see page. 93)	9 - 90	11
	Nastri NSTR-S Rivestimento in acciaio - Misure metriche <i>NSTR-S Strips</i> Steel covering - Metric sizes Su richiesta disponibili in altre esecuzioni (vedi pag. 93) Under request, available also in other execution (see page. 93)	500 x 125 500 x 250	12
	Boccole SF-1 Rivestimento in bronzo - Misure in pollici <i>SF-1 Bushings</i> Bronze covering - Inches sizes richiesta disponibili in altre esecuzioni (vedi pag. 93) Under request, available also in other execution (see page. 93)	1/8 - 7	13
	Boccole flangiate SF-1 F Rivestimento in bronzo - Misure in pollici <i>SF-1 F Flanged bushings</i> Bronze covering - Inches sizes Su richiesta disponibili in altre esecuzioni (vedi pag. 93) Under request, available also in other execution (see page. 93)	3/8 - 1 3/4	17
	Ralle WC SF-1 Rivestimento in bronzo - Misure in pollici <i>WC SF-1 Thrust washers</i> Bronze covering - Inches sizes Su richiesta disponibili in altre esecuzioni (vedi pag. 93) Under request, available also in other execution (see page. 93)	0,5 - 2,25	18

Foto prodotto Product photo	Tipo Type	Dimensioni Dimensions	Pagina Page
	Nastri NSTR-S Rivestimento in acciaio - Misure in pollici <i>NSTR-S Strips</i> Steel covering - Inches sizes Su richiesta disponibili in altre esecuzioni (vedi pag.93) Under request, available also in other execution (see page. 93)	19,69 x 2,75 19,69 x 4,00	19
	Boccole SF-2 Superficie alveolata - Rivestimento in bronzo - Misure metriche <i>SF-2 Bushings</i> Honey cones surface - Bronze covering - Metric sizes	6 - 300	24
	Ralle WCSF-2 Superficie alveolata - Rivestimento in bronzo - Misure metriche <i>WCSF-2 Thrust washers</i> Honey cones surface - Bronze covering - Metric sizes	9 - 62	26
	Nastri NSTR-1 Superficie alveolata - Misure metriche <i>NSTR-1 Strips</i> Honey cones surface - Metric sizes	500 x 120 500 x 200	27
	Nastri NSTR-2 Struttura con sovravello e superficie alveolata - Misure metriche <i>NSTR-2 Strips</i> Honey cones surface with plate - Metric sizes	500 x 120 500 x 180	28
	Nastri NSTR-3 Struttura con sovravello e superficie non alveolata - Misure metriche <i>NSTR-3 Strips</i> With plate and without honey cones surface - Metric sizes	500 x 120 500 x 180	29
	Boccole SF-2 Superficie alveolata - Rivestimento in bronzo - Misure in pollici <i>SF-2 bushings</i> Honey cones surface - Bronze covering - Inches sizes	3/8 - 4	30

Foto prodotto Product photo	Tipo Type	Dimensioni Dimensions	Pagina Page
	<p>Ralle WC SF-2 Superficie alveolata - Rivestimento in bronzo - Misure in pollici</p> <p><i>WC SF-2 Thrust washers</i> <i>Honey cones surface - Bronze covering - Inches sizes</i></p>	0,5 - 2,25	32
	<p>Nastri NSTR-I Superficie alveolata - Misure in pollici</p> <p><i>NSTR-I Strips</i> <i>Honey cones surface - Inches sizes</i></p>	19,69 x 2,75 19,69 x 4,00	33
	<p>Boccole sinterizzate in bronzo BNZ/FE Misure metriche</p> <p><i>BNZ/IRON Sintered bronze bushings</i> <i>Metric sizes</i></p>	2 - 125	37
	<p>Boccole sinterizzate in bronzo flangiate BNZF/FF Misure metriche</p> <p><i>BNZF/IRON Sintered bronze flanged bushings</i> <i>Metric sizes</i></p>	2 - 100	43
	<p>Boccole 090/092 Rivestimento in bronzo - Misure metriche Disponibili con tasche a losanga ed a calotta</p> <p><i>090/092 Bushings - Bronze covering - Metric sizes</i> <i>Available with lozenge and spherical cap pockets</i></p>	10 - 300	52
	<p>Boccole flangiate 090F/092F Rivestimento in bronzo - Misure metriche Disponibili con tasche a losanga ed a calotta</p> <p><i>090F/092F Flanged bushings</i> <i>Bronze covering - Metric sizes Available with lozenge and spherical cap pockets</i></p>	12 - 300	55
	<p>Boccole bimetalliche BM1 Misure metriche</p> <p><i>BM1 Bimetal bushings</i> <i>Metric sizes</i></p> <p>Su richiesta disponibili in altre esecuzioni (vedi pag. 94/95) <i>Under request, available also in other execution (see page. 94/95)</i></p>	10 - 300	61

Foto prodotto Product photo	Tipo Type	Dimensioni Dimensions	Pagina Page
	Boccole bimetalliche flangiate BM1 F Misure metriche <i>BM1 F Bimetal flanged bushings</i> Metric sizes Su richiesta disponibili in altre esecuzioni (vedi pag. 94/95) <i>Under request, available also in other execution (see page. 94/95)</i>	40 - 95	63
	Ralle bimetalliche BM1 R Misure metriche <i>BM1 R Bimetal washers</i> Metric sizes Su richiesta disponibili in altre esecuzioni (vedi pag. 94/95) <i>Under request, available also in other execution (see page. 94/95)</i>	10 - 62	64
	Nastri NSTR-BM Rivestimento bimetallico - Misure metriche <i>NSTR-BM Strips</i> Bimetal covering - Metric sizes Su richiesta disponibili in altre esecuzioni (vedi pag. 94/95) <i>Under request, available also in other execution (see page. 94/95)</i>	500 x 150	65
	Boccole BG1 Ottone e grafite - Misure metriche <i>BG1 Bushings</i> Brass and graphite - Metric sizes Su richiesta disponibili in altre esecuzioni (vedi pag. 95/96) <i>Under request, available also in other execution (see page. 95/96)</i>	8 - 160	70
	Boccole flangiate BG1-F Ottone e grafite - Misure metriche <i>BG1-F Flanged bushings</i> Brass and graphite - Metric sizes Su richiesta disponibili in altre esecuzioni (vedi pag. 95/96) <i>Under request, available also in other execution (see page. 95/96)</i>	8 - 120	73
	Ralle BG1-W Ottone e grafite - Misure metriche <i>BG1-W Thrust washers</i> Brass and graphite - Metric sizes Su richiesta disponibili in altre esecuzioni (vedi pag. 95/96) <i>Under request, available also in other execution (see page. 95/96)</i>	10,2 - 120,5	75
	Piastre scorrevoli BG1-SP Ottone e grafite - Misure metriche <i>BG1-SP Sliding plates</i> Brass and graphite - Metric sizes Su richiesta disponibili in altre esecuzioni (vedi pag. 95/96) <i>Under request, available also in other execution (see page. 95/96)</i>	18 x 75 75 x 500	76

Foto prodotto Product photo	Tipo Type	Dimensioni Dimensions	Pagina Page
	Piastre lineari scorrevoli BG1-SPL Ottone e grafite - Misure metriche <i>BG1-SPL Linear sliding plates</i> Brass and graphite - Metric sizes Su richiesta disponibili in altre esecuzioni (vedi pag. 95/96) <i>Under request, available also in other execution (see page. 95/96)</i>	20 x 100 45 x 350	77
	Guide piane BG1-GP Ottone e grafite - Misure metriche <i>BG1-GP Plane guides</i> Brass and graphite - Metric sizes Su richiesta disponibili in altre esecuzioni (vedi pag. 95/96) <i>Under request, available also in other execution (see page. 95/96)</i>	28 x 75 200 x 300	78
	Guide piane scorrevoli BG1-GPS Ottone e grafite - Misure metriche <i>BG1-GPS Plane sliding guides</i> Brass and graphite - Metric sizes Su richiesta disponibili in altre esecuzioni (vedi pag. 95/96) <i>Under request, available also in other execution (see page. 95/96)</i>	50 x 80 160 x 80	79
	Boccole BG2 Ottone e grafite - Misure metriche <i>BG2 Bushings</i> Brass and graphite - Metric sizes Su richiesta disponibili in altre esecuzioni (vedi pag. 95/96) <i>Under request, available also in other execution (see page. 95/96)</i>	8 - 160	80
	Boccole flangiate BG2-F Ottone e grafite - Misure metriche <i>BG2-F Flanged bushings</i> Brass and graphite - Metric sizes Su richiesta disponibili in altre esecuzioni (vedi pag. 95/96) <i>Under request, available also in other execution (see page. 95/96)</i>	8 - 130	83
	Boccole BG4 Ghisa e grafite - Misure metriche <i>BG4 Bushings</i> Cast iron and graphite - Metric sizes Su richiesta disponibili in altre esecuzioni (vedi pag. 95/96) <i>Under request, available also in other execution (see page. 95/96)</i>	30 - 120	85
	Boccole flangiate BG4-F Ghisa e grafite - Misure metriche <i>BG4-F Flanged bushings</i> Cast iron and graphite - Metric sizes Su richiesta disponibili in altre esecuzioni (vedi pag. 95/96) <i>Under request, available also in other execution (see page. 95/96)</i>	30 - 100	86

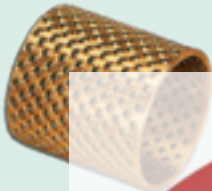
Foto prodotto Product photo	Tipo Type	Dimensioni Dimensions	Pagina Page
	<p>Boccole flangiate BG4-AF (con inserti di grafite anche sulla flangia) Ghisa e grafite - Misure metriche</p> <p><i>BG4-AF Flanged bushings (with graphite insert on the flange)</i> <i>Cast iron and graphite - Metric sizes</i></p> <p>Su richiesta disponibili in altre esecuzioni (vedi pag. 95/96) <i>Under request, available also in other execution (see page. 95/96)</i></p>	<p>12 - 60</p>	<p>87</p>
	<p>Boccole con sfere ingabbiate allineate BSI-A Misure metriche</p> <p><i>BSI-A Ball retainer straight line array</i> <i>Metric sizes</i></p> <p>Su richiesta disponibili con struttura in rame, alluminio e plastica (POM) <i>Under request copper, aluminium and plastic (POM) type available</i></p>	<p>19 - 80</p>	<p>90</p>
	<p>Boccole con sfere ingabbiate a spirale BSI-S Misure metriche</p> <p><i>BSI-S Ball retainer spiral array</i> <i>Metric sizes</i></p> <p>Su richiesta disponibili con struttura in rame, alluminio e plastica (POM) <i>Under request copper, aluminium and plastic (POM) type available</i></p>	<p>10 - 100</p>	<p>91</p>

1. Caratteristiche boccole SF-1

1. SF-1 bushings characteristics

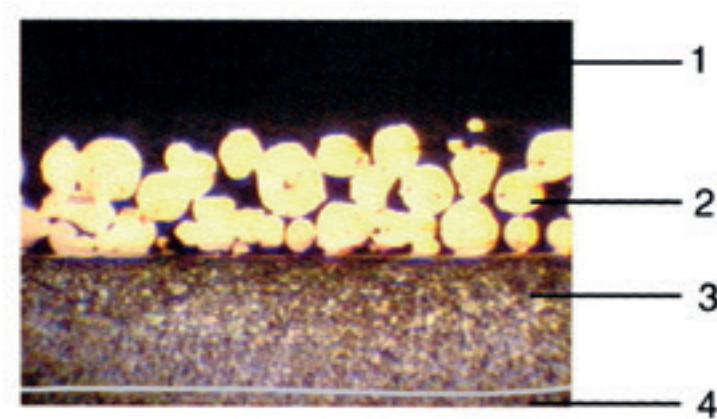

1. PTFE <i>PTFE</i>	0,01 ~ 0,03 mm
2. Bronzo poroso <i>Porous bronze</i>	0,2 ~ 0,30 mm
3. Armatura d'acciaio <i>Steel backing</i>	0,70 ~ 2,30 mm
4. Stagnatura <i>Tin plating</i>	~ 0,005 mm
Ramatura <i>Copper-plating</i>	~ 0,008 mm

1.1 Caratteristiche e funzionalità

1.1 Functionality and characteristics

Le boccole SF-1 presentano molteplici caratteristiche che si possono così riassumere:

The SF-1 bushings present multiple characteristics which can be summarized as follows:

- esenti da lubrificazione
- elevata capacità di carico - 140 N/mm² grazie alla distribuzione del carico su ampie superfici elasto-plastiche
- elevata scorrevolezza e basso coefficiente d'attrito sia statico sia dinamico (nessun effetto stick-slip)
- temperatura d'esercizio da -195 °C a +250 °C
- vibrazioni, rumore ed inquinamento ridottissimi. Possibilità di utilizzare metalli di accoppiamento a bassa durezza facilitandone la lavorazione e riducendone i costi
- materiale leggero, compatto e con minimi ingombri
- facilità di montaggio
- non assorbono olio o acqua, presentano una bassa espansione ed un'alta conducibilità nonché una buona stabilità termica
- elevata resistenza chimica: possono essere ricoperti o placcati con materiali resistenti a liquidi, gas o solidi chimicamente aggressivi attraverso uno strato galvanico supplementare.

- exempt from lubrication
- elevated load capacities - 140 N/mm² due to large elasto-plastic surfaces
- elevated flow and low friction coefficients both static and dynamic (no stick-slip effect)
- the exercising temperature is from -195 °C to +250 °C.
- vibration, noise and pollution maximally reduced. The possibility to use coupling metals which have low hardness facilitating the work and reducing costs
- light weight materials, compact and with minimum encumbrance
- ease of mounting
- oil or water are not absorbed, presenting low expansion, high conductivity and excellent thermal stability
- elevated chemical resistance: easily covered with materials resistant to liquid, gas or solids which are chemically aggressive using a supplementary galvanic layer.

1.2 Utilizzo

Le boccole SF-1 trovano largo impiego nei veicoli idraulici, automobili, motociclette, macchine agricole, macchine tessili, macchine per la stampa, attrezzature ginniche e molte altre applicazioni.

Le boccole SF-1 hanno solitamente un buon adattamento iniziale (rodaggio) con un usura di 0,01 ~ 0,02 mm.

Durante la fase di rodaggio una parte della superficie in PTFE si deposita sull'albero o sulla superficie di strisciamento (fig. 1) formando così un film autolubrificante in grado di ridurre l'attrito e l'usura.

Dopo questa fase iniziale e con il progressivo aumento delle ore di funzionamento, al raggiungimento dell'80% di consumo di PTFE, si considera la boccia esaurita e quindi da sostituire.

La rugosità di superficie deve essere solitamente inferiore a 0,8 µ. La curva tipica di usura viene mostrata nella fig. 2.

1.2 Use

SF-1 bushings are widely used in hydraulic vehicles, automobiles, motorcycles, agricultural machines, textile machines, printing machines, gymnastic equipment and many other applications.

SF-1 bushings generally have good initial adaptability with a wear of 0,01 ~ 0,02mm.

During the adjustment period a part of the surface in PTFE is deposited on the shaft or on the contact surface (fig. 1) forming a self-lubricating film capable of reducing friction and wear.

After this initial phase and with progressive increases in the functioning hours, once 80% of the PTFE is consumed, the bushing is considered depleted and therefore should be replaced.

The roughness of the surface must generally be inferior to 0,8 µ. The typical wear curve is shown in fig. 2.

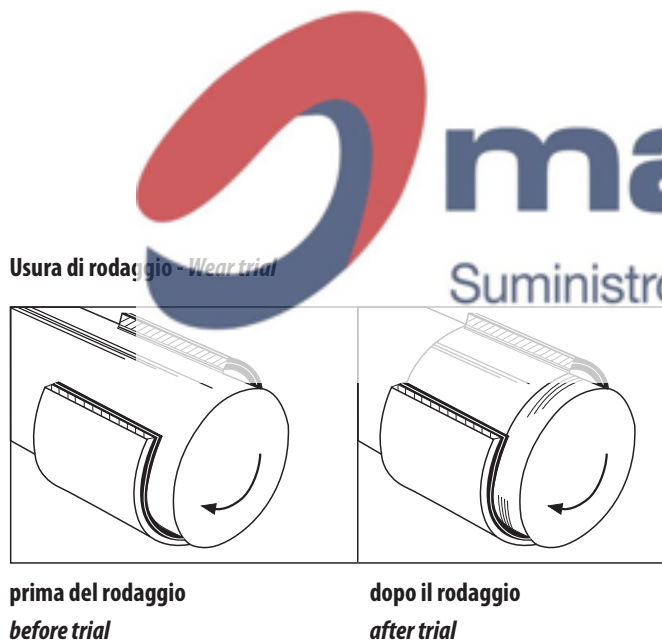

Fig. 1

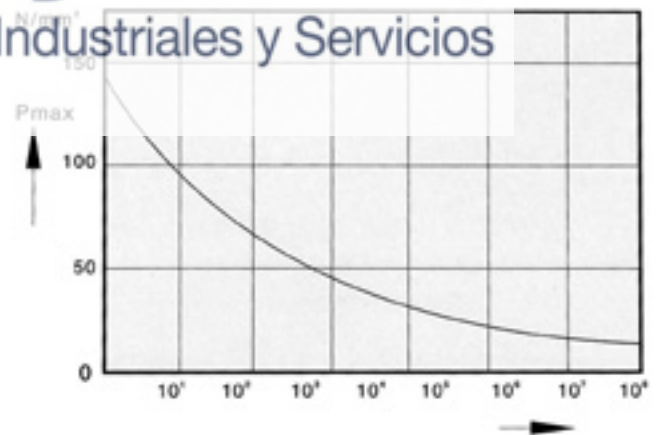

Fig. 2

1.3 Capacità di carico

La capacità di carico delle boccole è espressa attraverso il fattore di carico Pv ($N/mm^2 \cdot m/s$) dove P rappresenta il carico specifico e v la velocità. Il carico specifico massimo applicabile in condizioni costanti può raggiungere il valore di $140 N/mm^2$, mentre in condizioni dinamiche, quindi con movimenti rotatori ed oscillanti, il limite del carico specifico può scendere a $56 N/mm^2$.

La capacità di carico può essere influenzata dalla temperatura: è importante quindi mantenerla costante per ottenere le migliori prestazioni aumentando così la durata della boccola.

Se consideriamo F come carico totale, d il diametro interno e b la lunghezza, il limite del carico equivale a:

$$p = \frac{F}{d \cdot b}$$

Anche la lubrificazione può influenzare il fattore di carico, infatti il carico specifico p massimo ammissibile dipende dalle condizioni di ingrassaggio come riportato nella fig. 3.

1.3 Load capacity

The load capacity of the bushing is expressed using the load factor Pv ($N/mm^2 \cdot m/s$) where P represents the specific load and v the velocity. The specific maximum load applicable in constant conditions can reach a value of ($140 N/mm^2$), while in dynamic conditions, therefore with rotary and oscillating movement, the specific load limit can decrease to $56 N/mm^2$. The limit of the load can be influenced by the temperature: it is important to maintain constant temperature in order to obtain the best performances and therefore to increase the duration of the bushing.

If we consider F as total load, d the internal diameter and b the length, the load limit will be equal to:

The lubrication can influence the load factor too: in fact the maximum specific load p depends on the conditions of the greasing, as shown in fig. 3.

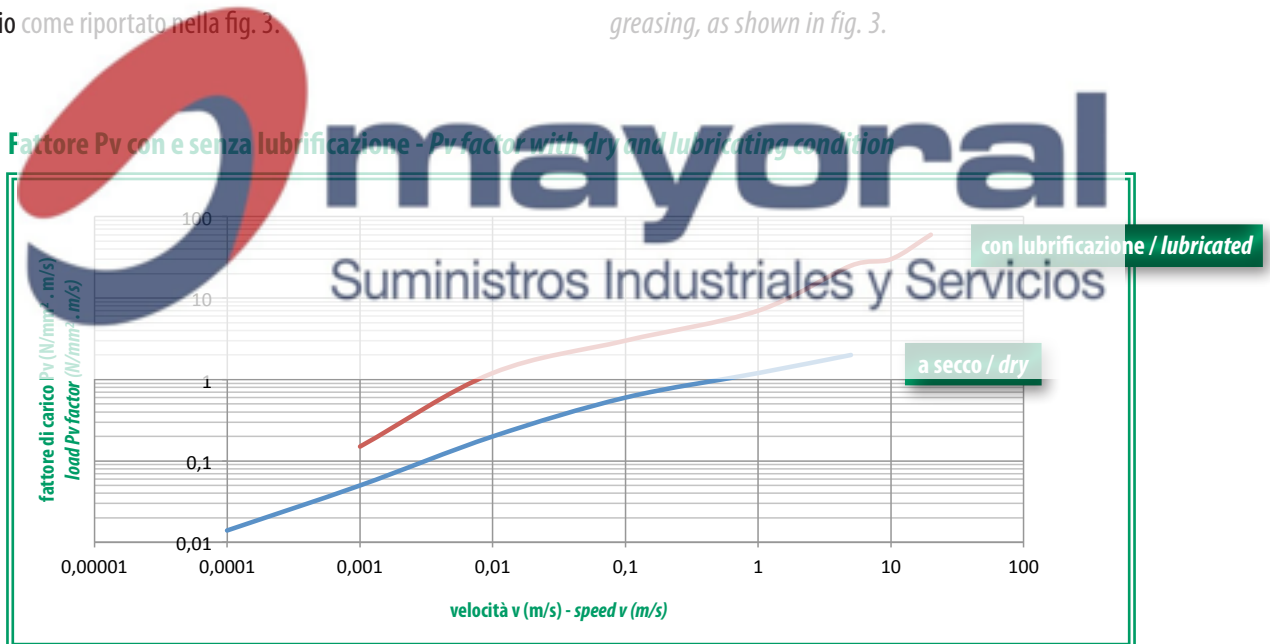

Fig. 3

1.4 Fluidi lubrificanti

Sebbene il materiale utilizzato per la costruzione del SF-1 sia di buona qualità ed utilizzabile a secco, qualora fosse impiegato in presenza di fluidi, liquidi e/o lubrificanti il limite Pv aumenterebbe sensibilmente; infatti la presenza di fluidi rende possibile lo smaltimento del calore d'attrito ed il contatto tra le superfici, aumentando la durata utile della boccia. La presenza di fluidi lubrificanti crea le condizioni adatte per il funzionamento idrodinamico, incrementando notevolmente la velocità di strisciamento a parità di carico specifico p. È opportuno verificare sempre la compatibilità della boccia, con il fluido presente, in quanto potrebbero verificarsi situazioni di controindicazione nell'utilizzo di un fluido piuttosto che un altro.

È consigliabile provare ad immergere metà boccia nel fluido per circa due settimane e verificare che la boccia risulti inalterata in ogni sua parte.

1.4 Lubricants fluids

Despite the material used for the construction of the SF-1 is of good quality and usable when dry, when used in the presence of fluids, liquids and or lubricants the limits Pv increase sensibly; in fact, the presence of fluids allows the dispersion of the friction heat possible and the contact between the surfaces, increasing the useful duration of the bushing. The presence of lubricating fluids creates the adapt conditions for the hydrodynamic functioning, incrementing noticeably the sliding velocity bling the specific load the seme. It is worthwhile to always verify the compatibility of the bushing with the fluid present because an undesirable effect could be experienced in the use of one fluid rather than another.

It is advisable to try to immerge hall of the bushing in the fluid for approximately 2 weeks to verify that the bushing remains unchanged in every part.

1.5 Temperatura

Nel caso in cui la temperatura rimanga tra 0 °C e 100 °C, l'impatto sul coefficiente d'attrito è piuttosto limitato; qualora superasse questo limite, il coefficiente d'attrito aumenterebbe rapidamente all'incirca del 50%. Con una temperatura stimata oltre i 200 °C ed a parità di fattore di carico, la durata della boccia si ridurrebbe dell'80% rispetto a quella registrata a 20 °C (tabella 1).

1.5 Temperature

In case the temperature remains between 0 °C and 100 °C, the impact of the friction coefficient is rather limited; once this limit is surpassed, the friction coefficient increases rapidly by approximately 50%. With an estimated temperature of over 200 °C and with costant load factor, the duration of the bushing would be reduced by 80% with respect to that registered at 20 °C (table 1).



Velocità (m/s) Speed (m/s)	Carico (N/mm ²) Load (N/mm ²)	Limite - Temperatura fattore Pv - Limit Pv at various temperature		
		20 °C	100 °C	200 °C
0,0001	140	0,014	0,014	0,014
0,001	50	0,5	0,3	0,1
0,01	6	0,6	0,35	0,12
1,0	1,2	1,2	0,72	0,24
5,0	0,4	2,0	1,0	0,40

SF-1 - SF-1F

Diametro esterno Outer diameter D	Tolleranze diametro esterno Outer diameter tolerances D	Tolleranze spessore Thickness tolerances S _B		Dimensioni smusso Chamfer dimensions S _B f ₁ f ₂		
≤ 10	+0,055 +0,025	0,75	0 -0,020	0,75	0,5 ± 0,3	-0,05 -0,30
10 < ≤ 18	+0,065 +0,030	1	+0,005 -0,020	1	0,6 ± 0,4	-0,1 -0,4
18 < ≤ 30	+0,075 +0,035	1,5	+0,005 -0,025	1,5	0,6 ± 0,4	-0,1 -0,6
30 < ≤ 50	+0,085 +0,045	2	+0,005 -0,030	2	1,2 ± 0,4	-0,1 -0,7
50 < ≤ 80	+0,100 +0,055	2,5	D ≤ 80 +0,005 -0,040	2,5	1,8 ± 0,6	-0,2 -1,0
80 < ≤ 120	+0,120 +0,070	2,5	80 < D ≤ 120 -0,010 -0,060	2,5	1,8 ± 0,6	-0,2 -1,0
120 < ≤ 180	+0,170 +0,100	2,5	D > 120 -0,035 -0,085	2,5	1,8 ± 0,6	-0,2 -1,0
180 < ≤ 305	+0,255 +0,125	2,5	D > 120 -0,035 -0,085	2,5	1,8 ± 0,6	-0,2 -1,0

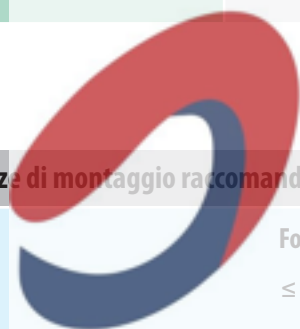

mayoral
Suministros Industriales y Servicios

Tolleranze di montaggio raccomandate:

Recommended mounting tolerances:

Albero:

≤ 4 = h 6

da 5 a 75 = f7

≥ 80 = h 8

Foro:

≤ 4 = H 6

> 4 = H 7

Shaft:

≤ 4 = h 6

from 5 to 75 = f7

≥ 80 = h 8

Bore:

≤ 4 = H 6

> 4 = H 7

Tolleranze di montaggio raccomandate SF-1F:

Recommended mounting tolerances SF-1F:

Albero:

f7

Foro:

≤ 4 = H 6

> 4 = H 7

Shaft:

f7

Bore:

≤ 4 = H 6

> 4 = H 7

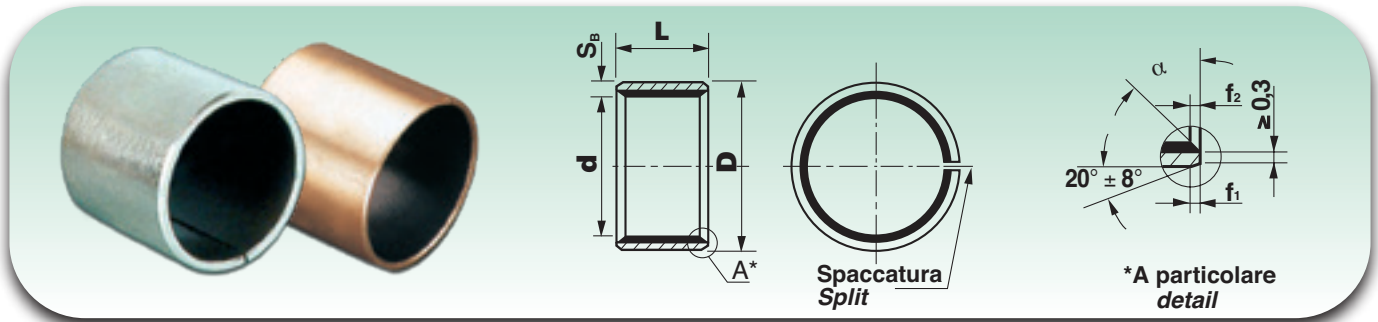

Dimensioni (mm) Dimensions (mm)		
d	D	L ^{±0,25}
2	3,5	3
		5
3	4,5	3
		4
		5
		6
		8
4	5,5	3
		4
		5
		6
		7
		8
		9
5	7	4
		5
		6
		7
		8
		10
		12
		14
		16
		20
6	8	4
		5
		6
		7
		8
		10
		12
7	9	10
		15
		20
		25
		30
8	10	4
		5
		6
		7
		8
		10
		12
		15
		16
		20
9	11	8
		10
		15
		20
10	12	5
		6
		7
		8
		10
		12
		13,5
		15
		20
		25
11	13	7,5
		10

Dimensioni (mm) Dimensions (mm)		
d	D	L ^{±0,25}
12	14	5
		6
		8
		10
		12
		15
		20
		25
		30
		30
13	15	8
		10
		15
		20
		5
		8
14	16	10
		12
		14
		15
		20
		25
		30
		32
		6
		8
15	17	10
		12
		15
		20
		25
		30
16	18	5
		8
		10
		12
		15
		16
		20
		25
		30
		35
17	19	10
		12
		15
		17
		20
		25
18	20	8
		9
		10
		12
		15
		16
		18
		20
		25
		30

Dimensioni (mm) Dimensions (mm)		
d	D	L ^{±0,25}
18	20	22
		25
		45
20	22	10
		15
		20
		22
		25
		30
		30
21	23	5
		10
		12
		15
		20
		25
		30
		20
		17
		10
22	25	12
		15
		17
		20
		25
		30
		30
24	27	14
		15
		20
		25
		28
25	28	30
		15
		20
		24
		25
		30
		5
		10
		12
		15
28	32	10
		12
		13
		15
		15



mayoral
Suministros Industriales y Servicios

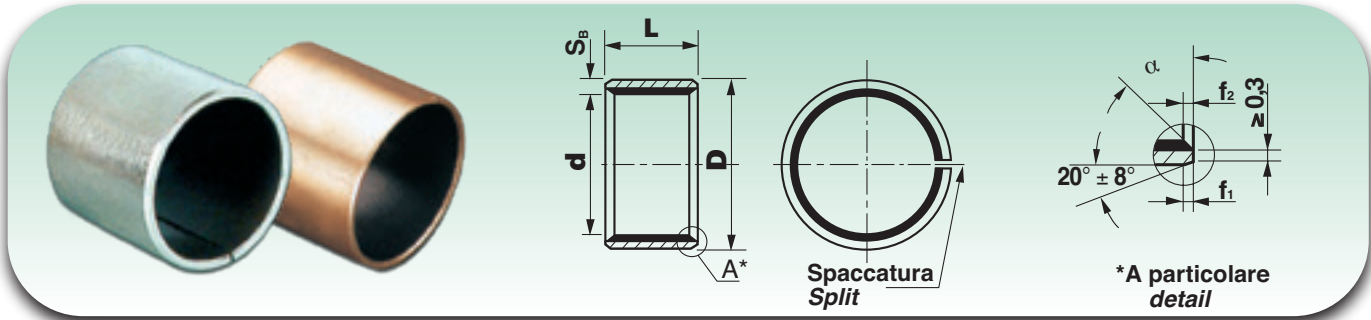

Dimensioni (mm) Dimensions (mm)		
d	D	L ^{±0,25}
28	32	20
		24
		25
		28
		30
		40
		43
30	34	50
		10
		12
		15
		20
		23
		25
		30
		32
		35
32	35	40
		50
		14
		8
		15
32	36	20
		25
		30
		40
		50
35	39	12
		14
		15
		20
		25
		26
		30
		35
		40
		50
36	40	40
37	41	20
38	42	15
		20
		25
		30
		38
40	44	40
		12
		15
		20
		25
		30
		35
40		

Dimensioni (mm) Dimensions (mm)		
d	D	L ^{±0,25}
40	44	45
41	45	50
45	50	15
		20
		25
		30
		40
		45
		50
50	55	15
		20
		25
		30
		40
		45
		50
		60
		70
		15
55	60	20
		30
		35
		40
		50
56	61	60
		20
		25
		30
		35
		40
		50
60	65	55
		60
		70
		80
		25
		30
		35
		40
		50
		60
65	70	65
		70
		75
		80
		25
		30
		35
70	75	40
		50
		60
		70
		80
		90
		100

Dimensioni (mm) Dimensions (mm)		
d	D	L ^{±0,25}
70	75	70
75	80	80
		30
		40
		50
		60
		70
		75
80	85	80
		85
		90
		25
		30
		35
		40
		50
		60
		70
85	90	80
		100
		30
		40
		50
90	95	60
		70
		80
		90
		100
		120
		20
		30
		40
		50
95	100	60
		80
		95
		100
		140
		50
		60
100	105	70
		80
		100
		115
		60
		70
		80
105	110	60
		80

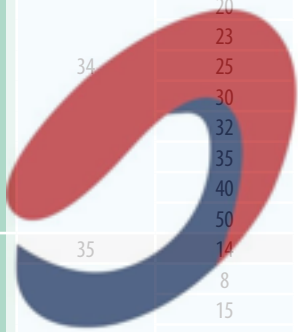

mayoral
Suministros Industriales y Servicios

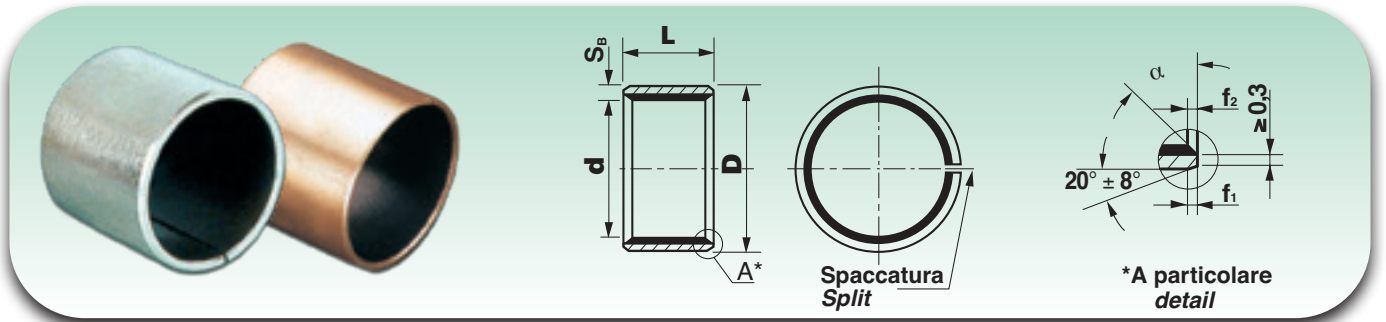

Dimensioni (mm) Dimensions (mm)		
d	D	L ^{±0,25}
105	110	100
		105
		115
110	115	50
		60
		80
		100
		115
		120
115	120	50
		60
		70
		115
120	125	40
		50
		60
		70
		80
		95
		100
		120
125	130	50
		60
		100
130	135	115
		125
		25
		50
		60
		80
135	140	100
		130
		40
		60
		70

Dimensioni (mm) Dimensions (mm)		
d	D	L ^{±0,25}
140	145	50
		60
		80
		90
145	150	100
		120
		140
		60
150	155	100
		50
		60
		80
		100
		150
		60
155	160	100
		40
		50
		60
160	165	80
		115
		160
165	170	60
		100
		65
170	175	100
		60
		100
175	180	60
		100
		60
180	185	80
		100
		180
		60
190	195	80
		100
		60
		100

Dimensioni (mm) Dimensions (mm)		
d	D	L ^{±0,25}
190	195	190
		60
200	205	80
		100
		200
		60
205	210	100
		60
210	215	100
		60
215	220	60
		100
		50
220	225	60
		80
		100
		220
		185
225	230	60
		100
		230
230	235	100
		60
		240
240	245	100
		60
		80
		100
250	255	100
		80
		250
260	265	80
		100
		260
280	285	60
		80
		100
		280
300	305	60
		80
		100
		300
445	450	125

Per ordinare specificare: SF-1 + d + L

To order, please specify: SF-1 + d + L

Possano essere fornite boccole a disegno per quantità.

Bushings made according drawings can be supplied if large quantities are ordered.

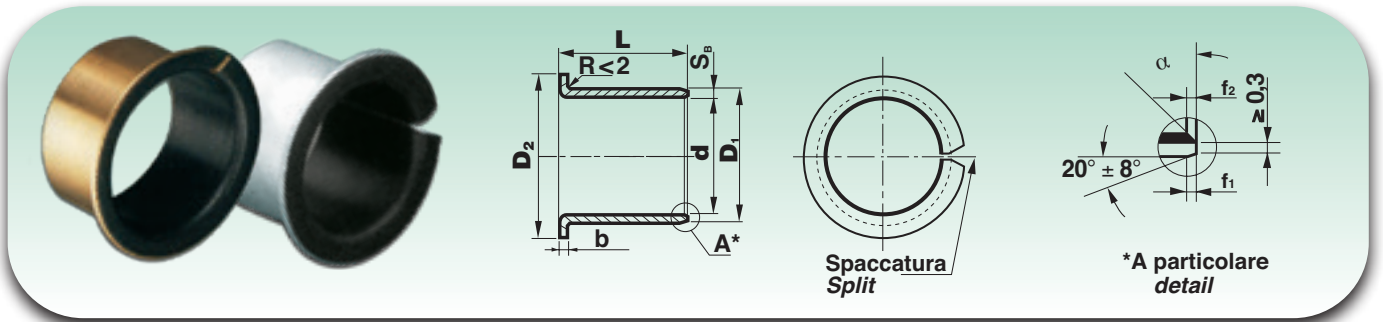

Sigla Designation	Dimensioni (mm) Dimensions (mm)				
	d	D ₁	D ₂ ^{±0,50}	L ^{±0,25}	b ^{-0,2}
F 3-4	3	4,5	7	4	0,75
F 4-3,7	4	5,5	9	3,7	0,75
F 4-4				4	
F 4-5				5	
F 4-6				6	
F 4-7				7	
F 4-8				8	
F 5-4	5	7	10	4	1
F 5-5				5	
F 5-6	5	7	10	6	1
F 5-7				7	
F 5-8				8	
F 6-4	6	8	12	4	1
F 6-7				7	
F 6-8				8	
F 6-12,7	6	8	12	12,7	1,5
F 8-4				4	
F 8-5,5				5,5	
F 8-6				6	
F 8-7,5				7,5	
F 8-8				8	
F 8-9,5	8	10	15	9,5	2
F 8-10				10	
F 10-5	10	12	18	5	1
F 10-5,5				5,5	
F 10-7				7	
F 10-9				9	
F 10-12				12	
F 10-17				17	
F 12-7	12	14	20	7	1
F 12-8				8	
F 12-9				9	
F 12-12				12	
F 12-15				15	
F 12-17	17				
F 14-12	14	16	22	12	1
F 14-17				17	
F 15-9	15	17	23	9	1
F 15-12				12	
F 15-17				17	
F 16-9	16	18	24	9	1
F 16-11				11	
F 16-12				12	
F 16-17				17	
F 18-12	18	20	26	12	1
F 18-17				17	
F 18-20				20	
F 18-22				22	

Sigla Designation	Dimensioni (mm) Dimensions (mm)								
	d	D ₁	D ₂ ^{±0,50}	L ^{±0,25}	b ^{-0,2}				
F 20-6	20	23	30	6	1,5				
F 20-6,5				6,5					
F 20-7,5				7,5					
F 20-11				11					
F 20-11,5				11,5					
F 20-12				12					
F 20-15				15					
F 20-16,5				16,5					
F 20-17				17					
F 20-21,5				21,5					
F 20-22	22	25	32	22	1,5				
F 22-11,5				12					
F 22-15				15					
F 22-16,5				17					
F 22-20	25	28	35	20	1,5				
F 25-11,5				11,5					
F 25-12				12					
F 25-16,5				16,5					
F 25-17				17					
F 25-21,5				21,5					
F 25-22	30	34	42	22	2				
F 30-16				16					
F 30-26				26					
F 30-30	32	36	43	30	2				
F 32-25				25					
F 35-9				35		39	47	9	2
F 35-16								16	
F 35-20	20								
F 35-26	26								
F 38-30	38	42	52	30	2				
F 40-16	40	44	53	16	2				
F 40-26				26					
F 40-40				40					
F 45-16	45	50	60	16	2,5				
F 45-20				20					
F 45-25				25					
F 45-26				26					
F 45-30				30					
F 45-32,5				32,5					
F 45-40	55	60	70	40	2,5				
F 45-50				50					
F 50-20	50	55	65	20	2,5				
F 50-30				30					
F 50-40				40					
F 55-30	55	60	70	30	2,5				
F 55-40				40					
F 60-30	60	65	75	30	2,5				
F 60-40				40					
F 60-50				50					



mayoral
Suministros Industriales y Servicios

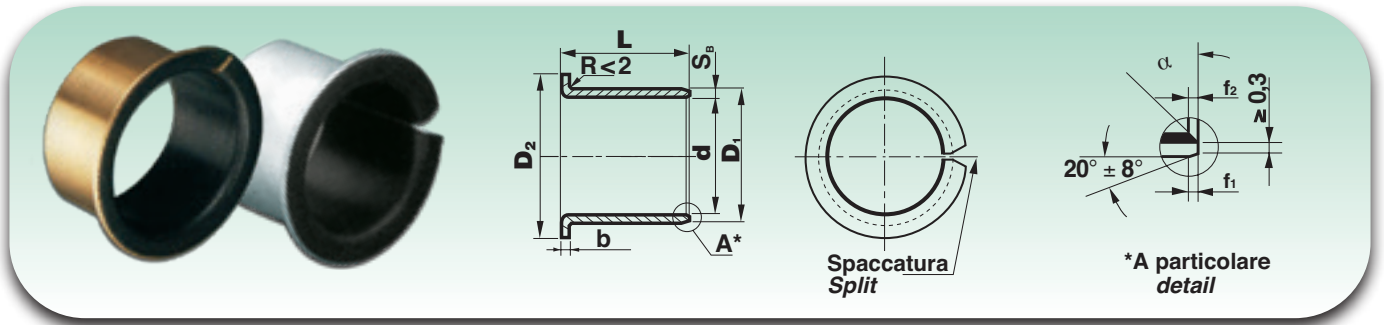

Sigla Designation	Dimensioni (mm) Dimensions (mm)				
	d	D ₁	D ₂ ^{±0,50}	L ^{±0,25}	b ^{-0,2}
F 65-30	65	70	80	30	2,5
F 65-40				40	
F 70-30	70	75	85	30	2,5
F 70-40				40	
F 75-30	75	80	90	30	2,5
F 75-40				40	
F 80-30	80	85	95	30	2,5
F 80-40				40	

Sigla Designation	Dimensioni (mm) Dimensions (mm)				
	d	D ₁	D ₂ ^{±0,50}	L ^{±0,25}	b ^{-0,2}
F 85-30	85	90	100	30	2,5
F 85-40				40	
F 90-30	90	95	105	30	2,5
F 90-40				40	
F 95-30	95	100	110	30	2,5
F 95-40				40	
F 120-90	120	125	140	90	2,5
-	-	-	-	-	-



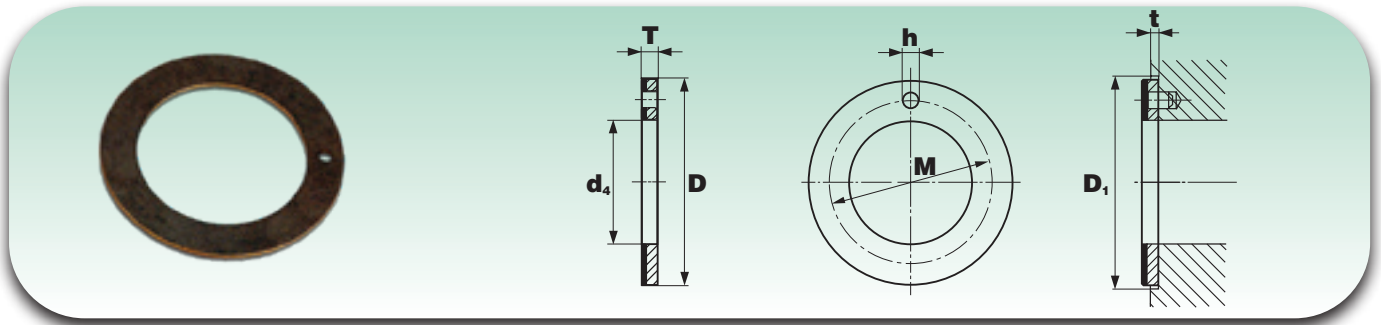

Sigla Designation	Dimensioni (mm) Dimensions (mm)				Dimensioni di montaggio (mm) Mounting dimensions (mm)		
	$d_4^{\pm 0,25}$	$D^{-0,25}$	$T^{-0,05}$	$M^{\pm 0,15}$	$h^{\begin{smallmatrix} +0,4 \\ +0,1 \end{smallmatrix}}$	$t^{\pm 0,2}$	$D_1^{+0,12}$
WC-1B 9	9	19	1	14	2	0,5	19
WC-1B 10	10	20	1,5	15	1,5	1	20
WC-1B 12	12	24	1,5	18	1,5	1	24
WC-1B 14	14	26	1,5	20	2	1	26
WC-1B 15	15	28	1	21,5	2	1	28
WC-1B 16	16	30	1,5	23	2	1	30
WC-1B 18	18	32	1,5	25	2	1	32
WC-1B 20	20	36	1,5	28	3	1	36
WC-1B 22	22	38	1,5	30	3	1	38
WC-1B 24	24	42	1,5	33	3	1	42
WC-1B 26	26	44	1,5	35	4	1	44
WC-1B 28	28	48	1,5	38	4	1	48
WC-1B 30	30	52	1,5	41	4	1	52
WC-1B 32	32	54	1,5	43	4	1	54
WC-1B 35	35	58	1,5	46,5	4	1	58
WC-1B 38	38	62	1,5	50	4	1	62
WC-1B 40	40	64	1,5	52	4	1	64
WC-1B 42	42	66	1,5	54	4	1	66
WC-1B 45	45	70	1,5	57,5	4	1	70
WC-1B 48	48	74	2	61	4	1,5	74
WC-1B 50	50	78	2	65	4	1,5	76
WC-1B 52	52	78	2	65	4	1,5	78
WC-1B 60	60	90	2	75	5	1,5	90
WC-1B 62	62	90	2	76	4	1,5	90
WC-1B 90	90	130	2	110	5	2	130

Per ordinare specificare: sigla

To order, please specify: designation

Le tolleranze riportate in questa pagina rispettano la norma ISO 6525:1983

The tolerance values given on this page comply with standard ISO 6525:1983

Consigliamo l'utilizzo di un perno o di una vite di arresto per evitare la rotazione. Il fermo deve essere incassato sotto il piano della ralla di almeno 0,25 mm.

A dowel or counter grub screw should be used to prevent rotation, but the head must be recessed at least 0,25 mm below the thrust washer surface.

Su richiesta disponibili:

• senza foro

On request, available also:

• without hole

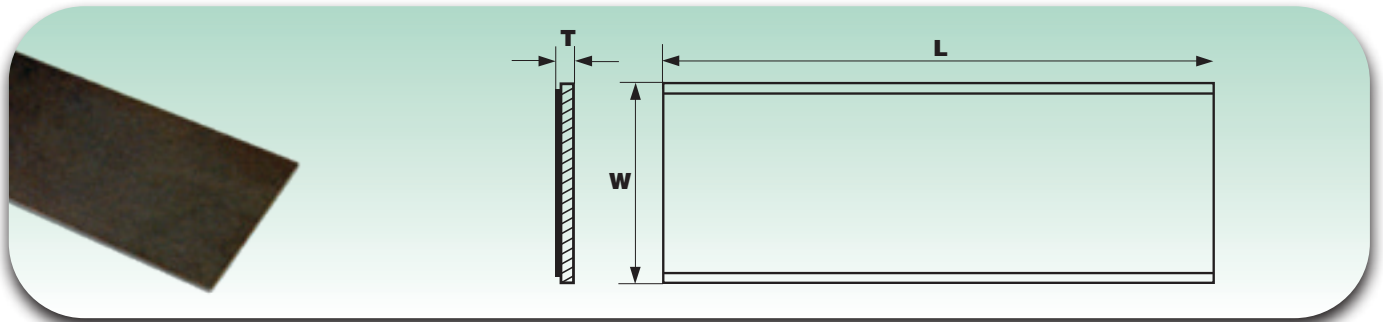

Sigla <i>Designation</i>	Dimensioni (mm) - <i>Dimensions (mm)</i>		
	Lunghezza <i>Length</i> L ±1	Altezza <i>Width</i> W ±1	Spessore <i>Thickness</i> T -0.05
NSTR-S 050125	500	125	0,50
NSTR-S 075125	500	125	0,75
NSTR-S 100125	500	125	1,0
NSTR-S 150125	500	125	1,5
NSTR-S 200125	500	125	2,0
NSTR-S 250125	500	125	2,5
NSTR-S 300125	500	125	3
NSTR-S 150200	500	200	1,5
NSTR-S 200200	500	200	2,0
NSTR-S 250200	500	200	2,5
NSTR-S 300200	500	200	3,0
NSTR-S 200250	500	250	2,0
NSTR-S 250250	500	250	2,5
NSTR-S 300250	500	250	3,0

Per ordinare specificare: sigla

To order, please specify: designation



mayoral

Suministros Industriales y Servicios

Su richiesta disponibili:

- con rivestimento in bronzo (NSTR-SB)
- versione 090 (NSTR 090)

On request, available also:

- with bronze covering (NSTR-SB)
- 090 version (NSTR 090)

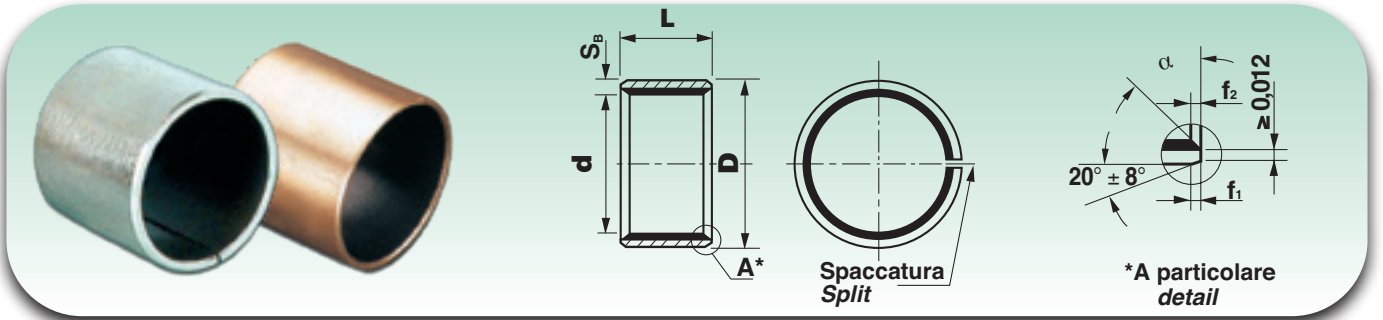

Sigla Designation	Dimensioni (pollici/mm) Dimensions (inches/mm)					
	d		D		L ±0,010"	
	inch.	mm	inch.	mm	inch.	mm
1/8-1/8	1/8	3,18	3/16	4,76	1/8	3,18
1/8-3/16					3/16	4,76
5/32-5/32	5/32	3,97	7/32	5,56	5/32	3,97
5/32-1/4					1/4	6,35
3/16-3/16	3/16	4,76	1/4	6,35	3/16	4,76
3/16-1/4					1/4	6,35
3/16-3/8					3/8	9,53
1/4-1/4	1/4	6,35	5/16	7,94	1/4	6,35
1/4-3/8					3/8	9,53
5/16-3/8	5/16	7,94	3/8	9,53	3/8	9,53
5/16-1/2					1/2	12,70
3/8-3/16	3/8	9,53	15/32	11,91	3/16	4,76
3/8-1/4					1/4	6,35
3/8-3/8					3/8	9,53
3/8-1/2	3/8	9,53	15/32	11,91	1/2	12,70
3/8-5/8					5/8	15,88
3/8-3/4	3/8	9,53	17/32	13,49	3/4	19,05
7/16-3/8					3/8	9,53
7/16-1/2	7/16	11,11	17/32	13,49	1/2	12,70
7/16-3/4					3/4	19,05
1/2-1/4	1/2	12,70	19/32	15,80	1/4	6,35
1/2-3/8					3/8	9,53
1/2-1/2					1/2	12,70
1/2-5/8	1/2	12,70	19/32	15,80	5/8	15,88
1/2-3/4					3/4	19,05
1/2-7/8	1/2	12,70	19/32	15,80	7/8	22,23
9/16-5/16					9/16	14,29
9/16-3/8	3/8	9,53				
9/16-1/2	1/2	12,70				
9/16-5/8	9/16	14,29	21/32	16,67	5/8	15,88
9/16-3/4					3/4	19,05
5/8-1/4	5/8	15,88	23/32	18,26	1/4	6,35
5/8-1/2					1/2	12,70
5/8-5/8					5/8	15,88
5/8-3/4	5/8	15,88	23/32	18,26	3/4	19,05
5/8-7/8					7/8	22,23
5/8-1	5/8	15,88	23/32	18,26	1	25,40
11/16-7/8					11/16	17,46
3/4-1/4	3/4	19,05	7/8	22,23	1/4	6,35
3/4-3/8					3/8	9,53
3/4-1/2					1/2	12,70
3/4-5/8	3/4	19,05	7/8	22,23	5/8	15,88
3/4-3/4					3/4	19,05
3/4-1	3/4	19,05	7/8	22,23	1	25,40
13/16-3/4					13/16	20,64
13/16-1/2	13/16	20,64	15/16	23,81	1/2	12,70
7/8-1/4					7/8	22,23

Sigla Designation	Dimensioni (pollici/mm) Dimensions (inches/mm)					
	d		D		L ±0,010"	
	inch.	mm	inch.	mm	inch.	mm
7/8-3/8	7/8	22,23	1	25,40	3/8	9,53
7/8-3/4					3/4	19,05
7/8-7/8					7/8	22,23
7/8-1					1	25,40
7/8-1 1/4					1 1/4	31,75
1-3/8	1	25,40	1 1/8	28,58	3/8	9,53
1-1/2					1/2	12,70
1-3/4					3/4	19,05
1-1	1	25,40	1 1/8	28,58	1	25,40
1-1 1/4					1 1/4	31,75
1-1 1/2	1	25,40	1 1/8	28,58	1 1/2	38,10
1 1/8-1 1/8					3/8	9,53
1 1/8-5/8	1 1/8	28,58	1 9/32	32,54	5/8	15,88
1 1/8-3/4					3/4	19,05
1 1/8-1	1 1/8	28,58	1 9/32	32,54	1	25,40
1 1/4-3/8					3/8	9,53
1 1/4-3/4	1 1/4	31,75	1 13/32	35,72	3/4	19,05
1 1/4-7/8					7/8	22,23
1 1/4-1	1 1/4	31,75	1 13/32	35,72	1	25,40
1 1/4-1 1/4					1 1/4	31,75
1 1/4-1 1/2	1 1/4	31,75	1 13/32	35,72	1 1/2	38,10
1 1/4-3/4					3/4	19,05
1 1/2-1/4	1 1/2	38,10	1 11/32	42,07	1 3/4	44,45
1 1/2-3/8					5/8	15,88
1 1/2-1/2	1 1/2	38,10	1 11/32	42,07	3/4	19,05
1 1/2-5/8					1	25,40
1 1/2-3/4	1 1/2	38,10	1 11/32	42,07	1 3/8	34,93
1 1/2-7/8					1 1/2	38,10
1 3/8-1	1 3/8	34,93	1 17/32	38,89	1	25,40
1 3/8-1 3/8					1 3/8	34,93
1 3/8-1 1/2	1 3/8	34,93	1 17/32	38,89	1 1/2	38,10
1 3/8-1 3/4					1 3/4	44,45
1 1/2-1/2	1 1/2	38,10	1 21/32	42,07	1/2	12,70
1 1/2-1					1	25,40
1 1/2-1 1/8	1 1/2	38,10	1 21/32	42,07	1 1/8	28,58
1 1/2-1 1/4					1 1/4	31,75
1 1/2-1 1/2	1 1/2	38,10	1 21/32	42,07	1 1/2	38,10
1 1/2-2					2	50,80
1 5/8-1	1 5/8	41,28	1 25/32	45,24	1	25,40
1 5/8-1 1/2					1 1/2	38,10
1 3/4-1	1 3/4	44,45	1 15/16	49,21	1	25,40
1 3/4-1 1/2					1 1/2	38,10
1 3/4-1 3/4	1 3/4	44,45	1 15/16	49,21	1 3/4	44,45
1 7/8-3/4					3/4	19,05
1 7/8-1	1 7/8	47,63	2 1/16	52,39	1	25,40
1 7/8-1 7/8					1 7/8	47,63
1 7/8-2 1/4	1 7/8	47,63	2 1/16	52,39	2 1/4	57,15
2-1/2					1/2	12,70
2-1	2	50,80	2 3/16	55,56	1	25,40
2-1 1/2					1 1/2	38,10
2-1 3/4	1 3/4	44,45				



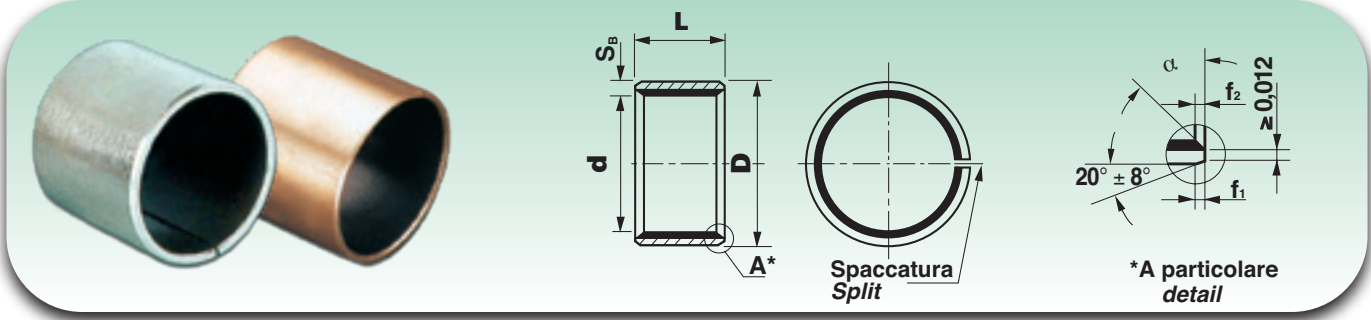

Sigla Designation	Dimensioni (pollici/mm) Dimensions (inches/mm)					
	d		D		L ±0,010"	
	inch.	mm	inch.	mm	inch.	mm
2 - 2					2	50,80
2 - 2 1/2	2	50,80	2 3/16	55,56	2 1/2	63,50
2 1/8 - 3	2 1/8	53,98	2 5/16	58,74	3	76,20
2 1/4 - 1 3/4					1 3/4	44,45
2 1/4 - 2					2	50,80
2 1/4 - 2 1/4					2 1/4	57,15
2 1/4 - 2 1/2					2 1/2	63,50
2 1/4 - 3	2 1/4	57,15	2 7/16	61,91	3	76,20
2 1/4 - 3 1/2					3 1/2	88,90
2 1/4 - 3 3/4					3 3/4	95,25
2 1/4 - 4					4	101,60
2 1/4 - 4 1/4					4 1/4	107,95
2 1/2 - 1					1	25,40
2 1/2 - 1 5/8					1 5/8	41,28
2 1/2 - 2					2	50,80
2 1/2 - 2 1/2					2 1/2	63,50
2 1/2 - 3	2 1/2	63,50	2 11/16	68,26	3	76,20
2 1/2 - 3 1/2					3 1/2	88,90
2 1/2 - 3 3/4					3 3/4	95,25
2 1/2 - 4					4	101,60
2 1/2 - 4 1/2					4 1/2	114,30
2 1/2 - 4 3/4					4 3/4	120,65
2 3/4 - 2					2	50,80
2 3/4 - 2 1/4					2 1/4	57,15
2 3/4 - 2 1/2					2 1/2	63,50
2 3/4 - 3					3	76,20
2 3/4 - 3 1/2	2 3/4	69,85	2 15/16	74,61	3 1/2	88,90
2 3/4 - 3 3/4					3 3/4	95,25
2 3/4 - 4					4	101,60
2 3/4 - 4 1/2					4 1/2	114,30
2 3/4 - 4 3/4					4 3/4	120,65
2 3/4 - 5					5	127,00
2 7/8 - 2					2	50,80
2 7/8 - 2 1/4					2 1/4	57,15
2 7/8 - 2 1/2					2 1/2	63,50
2 7/8 - 3					3	76,20
2 7/8 - 3 1/2	2 7/8	73,03	3 1/16	77,79	3 1/2	88,90
2 7/8 - 3 3/4					3 3/4	95,25
2 7/8 - 4					4	101,60
2 7/8 - 4 1/2					4 1/2	114,30
2 7/8 - 4 3/4					4 3/4	120,65
2 7/8 - 5					5	127,00
3 - 2					2	50,80
3 - 2 1/4					2 1/4	57,15
3 - 2 1/2	3	76,20	3 3/16	80,96	2 1/2	63,50
3 - 3					3	76,20
3 - 3 1/2					3 1/2	88,90

Sigla Designation	Dimensioni (pollici/mm) Dimensions (inches/mm)					
	d		D		L ±0,010"	
	inch.	mm	inch.	mm	inch.	mm
3 - 3 3/4					3 3/4	95,25
3 - 4					4	101,60
3 - 4 1/2	3	76,20	3 3/16	80,96	4 1/2	114,30
3 - 4 3/4					4 3/4	120,65
3 - 5					5	127,00
3 1/4 - 2					2	50,80
3 1/4 - 2 3/8					2 3/8	60,33
3 1/4 - 2 1/2					2 1/2	63,50
3 1/4 - 3					3	76,20
3 1/4 - 3 1/2	3 1/4	82,55	3 7/16	87,31	3 1/2	88,90
3 1/4 - 3 3/4					3 3/4	95,25
3 1/4 - 4					4	101,60
3 1/4 - 4 1/2					4 1/2	114,30
3 1/4 - 4 3/4					4 3/4	120,65
3 1/4 - 5					5	127,00
3 1/2 - 2					2	50,80
3 1/2 - 2 3/8					2 3/8	60,33
3 1/2 - 2 1/2					2 1/2	63,50
3 1/2 - 3					3	76,20
3 1/2 - 3 1/2	3 1/2	88,90	3 9/16	93,66	3 1/2	88,90
3 1/2 - 3 3/4					3 3/4	95,25
3 1/2 - 4					4	101,60
3 1/2 - 4 1/2					4 1/2	114,30
3 1/2 - 4 3/4					4 3/4	120,65
3 1/2 - 5					5	127,00
3 5/8 - 2					2	50,80
3 5/8 - 2 1/4					2 1/4	57,15
3 5/8 - 2 1/2					2 1/2	63,50
3 5/8 - 3					3	76,20
3 5/8 - 3 1/2	3 5/8	92,08	3 13/16	96,84	3 1/2	88,90
3 5/8 - 3 3/4					3 3/4	95,25
3 5/8 - 4					4	101,60
3 5/8 - 4 1/2					4 1/2	114,30
3 5/8 - 4 3/4					4 3/4	120,65
3 5/8 - 5					5	127,00
3 3/4 - 2					2	50,80
3 3/4 - 2 1/4					2 1/4	57,15
3 3/4 - 2 1/2					2 1/2	63,50
3 3/4 - 3					3	76,20
3 3/4 - 3 1/2	3 3/4	95,25	3 15/16	100,01	3 1/2	88,90
3 3/4 - 3 3/4					3 3/4	95,25
3 3/4 - 4					4	101,60
3 3/4 - 4 1/2					4 1/2	114,30
3 3/4 - 4 3/4					4 3/4	120,65
3 3/4 - 5					5	127,00
4 - 2					2	50,80
4 - 2 1/4	4	101,60	3 3/16	80,96	2 1/4	57,15



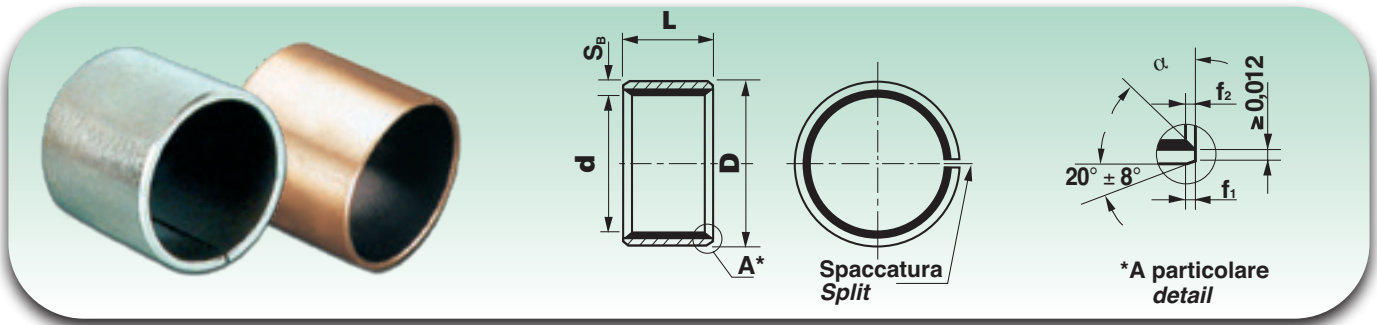

Sigla Designation	Dimensioni (pollici/mm) Dimensions (inches/mm)					
	d		D		L ±0,010"	
	inch.	mm	inch.	mm	inch.	mm
4-2 1/2	4	101,60	3 3/16	80,96	1 1/2	63,50
4-3					3	76,20
4-3 1/2					3 1/2	88,90
4-3 3/4					3 3/4	95,25
4-4					4	101,60
4-4 1/2					4 1/2	114,30
4-4 3/4					4 3/4	120,65
4-5					5	127,00
4 1/4-2					2	50,80
4 1/4-2 1/4					2 1/4	57,15
4 1/4-2 1/2	2 1/2	63,50				
4 1/4-3	3	76,20				
4 1/4-3 1/2	3 1/2	88,90				
4 1/4-3 3/4	3 3/4	95,25				
4 1/4-4	4	101,60				
4 1/4-4 1/2	4 1/2	114,30				
4 1/4-4 3/4	4 3/4	120,65				
4 1/4-5	5	127,00				
4 3/8-2	2	50,80				
4 3/8-2 1/4	2 1/4	57,15				
4 3/8-2 1/2	2 1/2	63,50				
4 3/8-3	3	76,20				
4 3/8-3 1/2	3 1/2	88,90				
4 3/8-3 3/4	3 3/4	95,25				
4 3/8-4	4	101,60				
4 3/8-4 1/2	4 1/2	114,30				
4 3/8-4 3/4	4 3/4	120,65				
4 3/8-5	5	127,00				
4 1/2-2	4 1/2	114,30	4 11/16	119,06	2	50,80
4 1/2-2 1/4					2 1/4	57,15
4 1/2-2 1/2					2 1/2	63,50
4 1/2-3					3	76,20
4 1/2-3 1/2					3 1/2	88,90
4 1/2-3 3/4					3 3/4	95,25
4 1/2-4					4	101,60
4 1/2-4 1/2					4 1/2	114,30
4 1/2-4 3/4					4 3/4	120,65
4 1/2-5					5	127,00
4 3/4-2	4 3/4	120,65	4 15/16	125,41	2	50,80
4 3/4-2 1/4					2 1/4	57,15
4 3/4-2 1/2					2 1/2	63,50
4 3/4-3					3	76,20
4 3/4-3 1/2					3 1/2	88,90
4 3/4-3 3/4					3 3/4	95,25
4 3/4-4					4	101,60
4 3/4-4 1/2					4 1/2	114,30
4 3/4-4 3/4					4 3/4	120,65
4 3/4-5					5	127,00

Sigla Designation	Dimensioni (pollici/mm) Dimensions (inches/mm)					
	d		D		L ±0,010"	
	inch.	mm	inch.	mm	inch.	mm
4 3/4-5	4 3/4	120,65	4 15/16	125,41	5	127,00
5-2	5	127,00	5 3/16	131,76	2	50,80
5-2 1/4					2 1/4	57,17
5-2 1/2					2 1/2	63,50
5-3					3	76,20
5-3 1/2					3 1/2	88,90
5-3 3/4					3 3/4	95,25
5-4					4	101,60
5-4 1/2					4 1/2	114,30
5-4 3/4					4 3/4	120,65
5-5					5	127,00
5 1/4-2	2	50,80				
5 1/4-2 1/4	2 1/4	57,15				
5 1/4-2 1/2	2 1/2	63,50				
5 1/4-3	3	76,20				
5 1/4-3 1/2	3 1/2	88,90				
5 1/4-3 3/4	3 3/4	95,25				
5 1/4-4	4	101,60				
5 1/4-4 1/2	4 1/2	114,30				
5 1/4-4 3/4	4 3/4	120,65				
5 1/4-5	5	127,00				
5 1/2-2	2	50,80				
5 1/2-2 1/4	2 1/4	57,15				
5 1/2-2 1/2	2 1/2	63,50				
5 1/2-3	3	76,20				
5 1/2-3 1/2	3 1/2	88,90				
5 1/2-3 3/4	3 3/4	95,25				
5 1/2-4	4	101,60				
5 1/2-4 1/2	4 1/2	114,30				
5 1/2-4 3/4	4 3/4	120,65				
5 1/2-5	5	127,00				
5 3/4-2	5 3/4	146,05	5 15/16	150,81	2	50,80
5 3/4-2 1/4					2 1/4	57,15
5 3/4-2 1/2					2 1/2	63,50
5 3/4-3					3	76,20
5 3/4-3 1/2					3 1/2	88,90
5 3/4-3 3/4					3 3/4	95,25
5 3/4-4					4	101,60
5 3/4-4 1/2					4 1/2	114,30
5 3/4-4 3/4					4 3/4	120,65
5 3/4-5					5	127,00
6-2	6	152,40	6 3/16	157,16	2	50,80
6-2 1/4					2 1/4	57,15
6-2 1/2					2 1/2	63,50
6-3					3	76,20
6-3 1/2					3 1/2	88,90
6-3 3/4					3 3/4	95,25



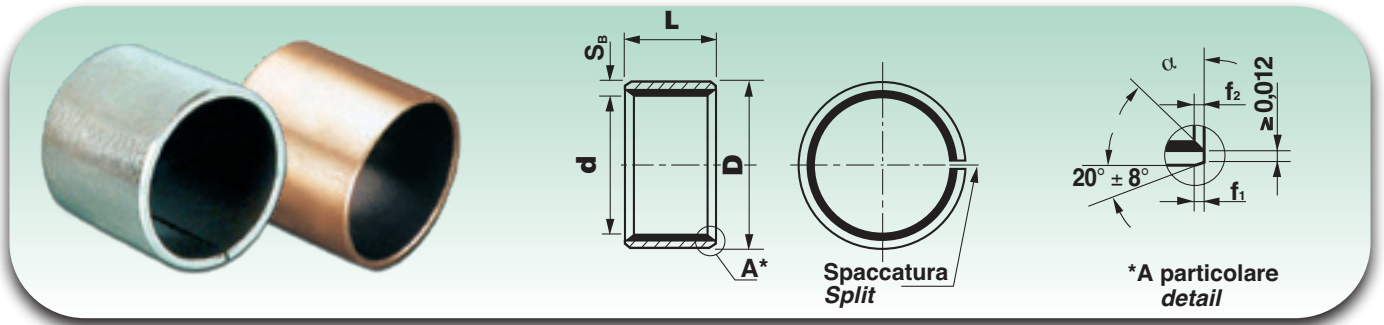

Sigla Designation	Dimensioni (pollici/mm) Dimensions (inches/mm)					
	d		D		L ±0,010"	
	inch.	mm	inch.	mm	inch.	mm
6 - 4	6	152,40	6 ³ / ₁₆	157,16	4	101,60
6 - 4 1/2					4 1/2	114,30
6 - 14 3/4					4 3/4	120,65
6 - 5					5	127,00
6 1/4 - 2	6 1/4	57,15	6 7/16	163,51	2	50,80
6 1/4 - 2 1/4					2 1/4	57,15
6 1/4 - 2 1/2					2 1/2	63,50
6 1/4 - 3					3	76,20
6 1/4 - 3 1/2					3 1/2	88,90
6 1/4 - 3 3/4					3 3/4	95,25
6 1/4 - 4					4	101,60
6 1/4 - 4 1/2	4 1/2	114,30				
6 1/4 - 4 3/4	4 3/4	120,65				
6 1/4 - 5	5	127,00				
6 1/2 - 2	6 1/2	165,10	6 11/16	169,86	2	50,80
6 1/2 - 2 1/4					2 1/4	57,15
6 1/2 - 2 1/2					2 1/2	63,50
6 1/2 - 3					3	76,20
6 1/2 - 3 1/2					3 1/2	88,90
6 1/2 - 3 3/4					3 3/4	95,25
6 1/2 - 4					4	101,60
6 1/2 - 4 1/2					4 1/2	114,30
6 1/2 - 5					5	127,00
6 1/2 - 6					6	152,40

Sigla Designation	Dimensioni (pollici/mm) Dimensions (inches/mm)									
	d		D		L ±0,010"					
	inch.	mm	inch.	mm	inch.	mm				
6 1/2 - 4 3/4	6 1/2	165,10	6 11/16	169,86	4 3/4	120,65				
6 1/2 - 5					5	127,00				
6 3/4 - 2					2	50,80				
6 3/4 - 2 1/4					2 1/4	57,15				
6 3/4 - 2 1/2	6 3/4	171,45	6 15/16	176,21	2 1/2	63,50				
6 3/4 - 3					3	76,20				
6 3/4 - 3 1/2					3 1/2	88,90				
6 3/4 - 3 3/4					3 3/4	95,25				
6 3/4 - 4					4	101,60				
6 3/4 - 4 1/2					4 1/2	114,30				
6 3/4 - 4 3/4					4 3/4	120,65				
6 3/4 - 5					5	127,00				
7 - 2					7	177,80	7 3/16	182,56	2	50,80
7 - 2 1/4									2 1/4	57,15
7 - 2 1/2	2 1/2	63,50								
7 - 3	3	76,20								
7 - 3 1/2	3 1/2	88,90								
7 - 3 3/4	3 3/4	95,25								
7 - 4	4	101,60								
7 - 4 1/2	4 1/2	114,30								
7 - 4 3/4	4 3/4	120,65								
7 - 5	5	127,00								

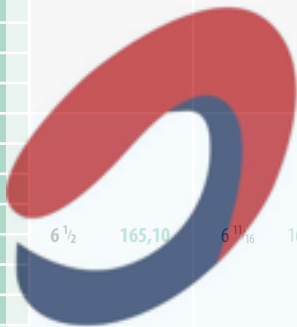

mayoral
Suministros Industriales y Servicios

Per ordinare specificare: SF-1 + sigla

To order, please specify: SF-1 + designation

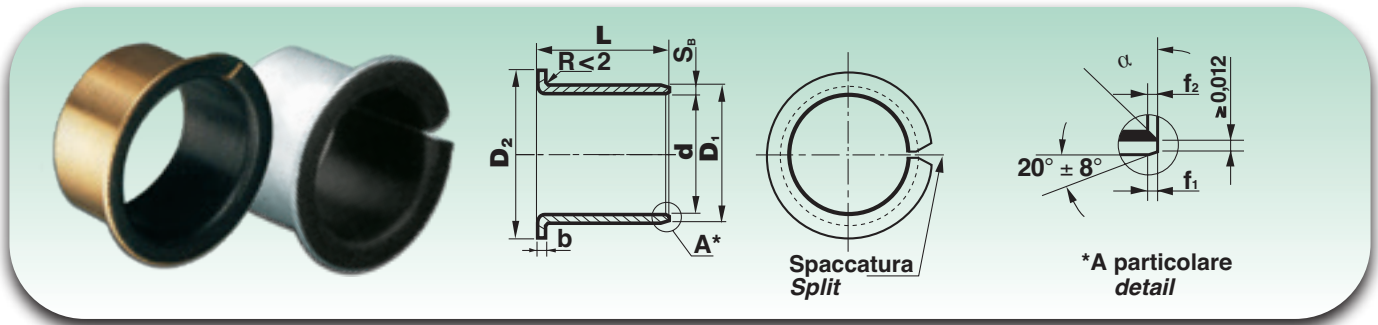

Sigla Designation	Dimensioni (pollici/mm) Dimensions (inches/mm)							
	d		D ₁		D ₂ ±0,020"		L ±0,010"	
	inch.	mm	inch.	mm	inch.	mm	inch.	mm
F 3/8-1/4	3/8	9,53	15/32	11,91	11/16	17,46	1/4	6,35
F 3/8-3/8							3/8	9,53
F 3/8-1/2							1/2	12,70
F 3/8-1/2							3/4	19,05
F 1/2-1/4	1/2	12,70	19/32	15,08	13/16	20,64	1/4	6,35
F 1/2-3/8							3/8	9,53
F 1/2-1/2							1/2	12,70
F 1/2-3/4							3/4	19,05
F 5/8-3/8	5/8	15,88	23/32	18,26	15/16	23,81	3/8	9,53
F 5/8-1/2							1/2	12,70
F 5/8-5/8							5/8	15,88
F 5/8-3/4							3/4	19,05
F 3/4-3/8	3/4	19,05	7/8	22,23	1 1/8	28,58	3/8	9,53
F 3/4-1/2							1/2	12,70
F 3/4-3/4							3/4	19,05
F 3/4-1							1	25,40
F 7/8-1/2	7/8	22,23	1	25,40	1 1/4	31,75	1/2	12,70
F 7/8-3/4							3/4	19,05
F 7/8-1							1	25,40
F 7/8-1 1/4							1 1/4	31,75
F 1-1/2	1	25,40	1 1/8	28,58	1 3/8	34,93	1/2	12,70
F 1-3/4							3/4	19,05
F 1-1							1	25,40
F 1-1 1/4							1 1/4	31,75
F 1 1/4-1	1 1/4	31,75	1 13/32	35,72	1 3/4	44,45	1	25,40
F 1 1/4-1 1/4							1 1/4	31,75
F 1 1/4-1 1/2							1 1/2	38,10
F 1 1/2-1							1	25,40
F 1 1/2-1 1/2	1 1/2	38,10	1 21/32	42,07	2	50,80	1 1/2	38,10
F 1 1/2-2							2	50,80
F 1 3/4-1							1	25,40
F 1 3/4-1 1/2							1 1/2	38,10
F 1 3/4-2	1 3/4	44,45	1 15/16	49,21	2 3/8	60,33	2	50,80

Per ordinare specificare: SF-1 + sigla

To order, please specify: SF-1 + designation

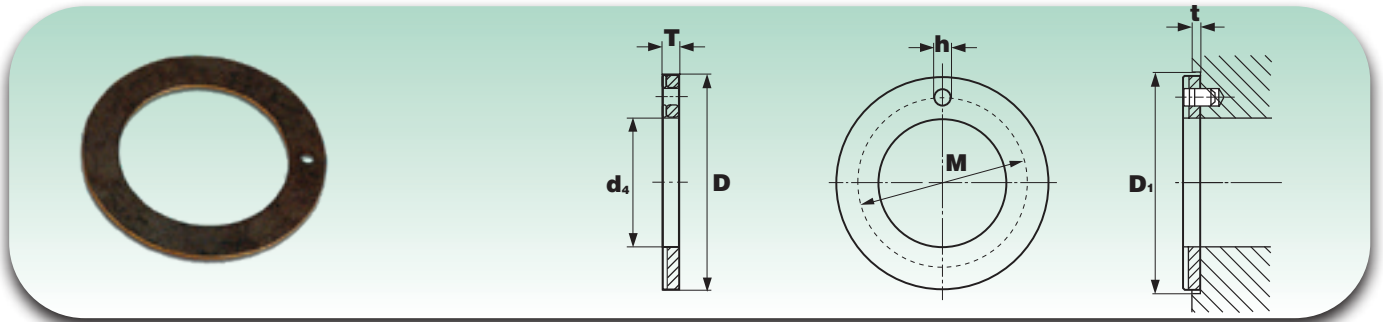

Sigla Designation	Dimensioni (pollici/mm) Dimensions (inches/mm)								Dimensioni di montaggio (pollici/mm) Mounting dimensions (inches/mm)					
	$d_4^{+0,010''}$		$D^{-0,010''}$		$T^{+0,0020''}$		$M^{-0,010''}$		$h^{+0,010''}$		$t^{\pm 0,010''}$		$D_1^{+0,010''}$	
	inch.	mm	inch.	mm	inch.	mm	inch.	mm	inch.	mm	inch.	mm	inch.	mm
WC-1 0500	0,500	12,70	0,875	22,23	0,061	1,549	0,692	17,58	0,067	1,70	0,04	1,02	0,875	22,23
WC-1 0562	0,562	14,27	1,000	25,40	0,061	1,549	0,786	19,96	0,067	1,70	0,04	1,02	1,000	25,40
WC-1 0625	0,625	15,88	1,125	28,58	0,061	1,549	0,880	22,35	0,099	2,51	0,04	1,02	1,125	28,58
WC-1 0687	0,687	17,45	1,187	30,15	0,061	1,549	0,942	23,93	0,099	2,51	0,04	1,02	1,187	30,15
WC-1 0750	0,750	19,05	1,250	31,75	0,061	1,549	1,005	25,53	0,099	2,51	0,04	1,02	1,250	31,75
WC-1 0812	0,812	20,62	1,375	34,93	0,061	1,549	1,009	27,91	0,099	2,51	0,04	1,02	1,375	34,93
WC-1 0875	0,875	22,23	1,500	38,10	0,061	1,549	1,192	30,28	0,130	3,30	0,04	1,02	1,500	38,10
WC-1 0937	0,937	23,80	1,625	41,28	0,061	1,549	1,286	32,66	0,130	3,30	0,04	1,02	1,625	41,28
WC-1 1000	1,000	25,40	1,750	44,45	0,061	1,549	1,380	35,05	0,130	3,30	0,04	1,02	1,750	44,45
WC-1 1125	1,125	28,58	2,000	50,80	0,061	1,549	1,567	39,80	0,161	4,09	0,04	1,02	2,000	50,80
WC-1 1250	1,250	31,75	2,125	53,98	0,061	1,549	1,692	42,98	0,161	4,09	0,04	1,02	2,125	53,98
WC-1 1375	1,375	34,93	2,250	57,15	0,061	1,549	1,817	46,15	0,161	4,09	0,04	1,02	2,250	57,15
WC-1 1500	1,500	38,10	2,500	63,50	0,061	1,549	2,005	50,93	0,192	4,88	0,04	1,02	2,500	63,50
WC-1 1625	1,625	41,28	2,625	66,68	0,061	1,549	2,130	54,10	0,192	4,88	0,04	1,02	2,625	66,68
WC-1 1750	1,750	44,45	2,750	69,85	0,061	1,549	2,255	57,28	0,192	4,88	0,04	1,02	2,750	69,85
WC-1 2000	2,000	50,80	3,000	76,20	0,091	2,311	2,505	63,63	0,192	4,88	0,07	1,78	3,000	76,20
WC-1 2125	2,125	53,98	3,125	79,38	0,091	2,311	2,630	66,80	0,192	4,88	0,07	1,78	3,125	79,38
WC-1 2250	2,250	57,15	3,250	82,55	0,091	2,311	2,755	69,98	0,192	4,88	0,07	1,78	3,250	82,55



mayoral

Suministros Industriales y Servicios

Per ordinare specificare: sigla

To order, please specify: designation

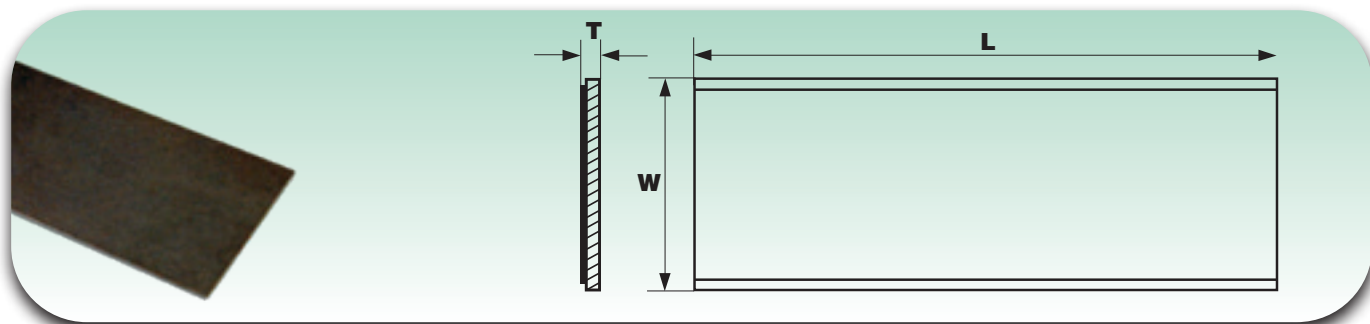

Sigla Designation	Dimensioni (pollici/mm) - Dimensions (inches/mm)					
	Lunghezza Length L +0,2"		Altezza Width W +0,1"		Spessore Thickness T -0,05"	
	inch.	mm	inch.	mm	inch.	mm
NSTR-S 00293-275	19,69	500,13	2,75	69,85	0,0293 ⁰ _{-0,0016}	0,74 ⁰ _{-0,0406}
NSTR-S 00447-400	19,69	500,13	4,00	101,60	0,0447 ⁰ _{-0,0016}	1,14 ⁰ _{-0,0406}
NSTR-S 00602-400	19,69	500,13	4,00	101,60	0,0602 ⁰ _{-0,0016}	1,53 ⁰ _{-0,0406}
NSTR-S 00756-400	19,69	500,13	4,00	101,60	0,0756 ⁰ _{-0,0016}	1,92 ⁰ _{-0,0406}
NSTR-S 00913-400	19,69	500,13	4,00	101,60	0,0913 ⁰ _{-0,0016}	2,32 ⁰ _{-0,0406}
NSTR-S 01210-400	19,69	500,13	4,00	101,60	0,1210 ⁰ _{-0,0020}	3,07 ⁰ _{-0,0508}

Per ordinare specificare: sigla

To order, please specify: designation



mayoral
Suministros Industriales y Servicios

Su richiesta disponibili:

- con rivestimento in bronzo (NSTR-SB)
- versione 090 (NSTR 090)

On request, available also:

- with bronze covering (NSTR-SB)
- 090 version (NSTR 090)



2. Caratteristiche boccole SF-2

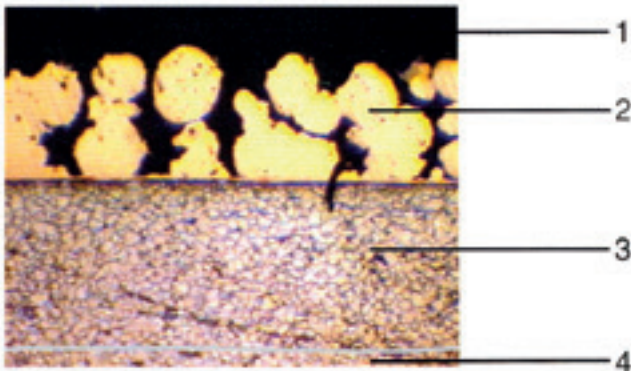

2. SF-2 bushings characteristics

1. Resina poliacetalica (POM)	0,30 ~ 0,50 mm
Modified polyacetal (POM)	0,30 ~ 0,50 mm
2. Bronzo poroso	0,20 ~ 0,30 mm
Porous bronze	0,20 ~ 0,30 mm
3. Armatura d'acciaio	0,40 ~ 2,20 mm
Steel backing	0,40 ~ 2,20 mm
4. Ramatura	~ 0,008 mm
Electro-plating Copper	~ 0,008 mm

2.1 Struttura SF-2

Sullo strato in acciaio viene sinterizzato lo strato poroso in bronzo, avente quale funzione il collegamento e la dispersione termica dello strato di strisciamento in resina poliacetalica che presenta degli alveoli per raccogliere e rilasciare gradualmente il lubrificante, in modo tale da ridurre l'attrito e proteggere la superficie di scorrimento della boccia.

Per facilitare la rilubrificazione le boccole SF-2 sono fornite di apposito foro esterno. È consigliabile l'utilizzo di un grasso al sapone di litio; l'MoS₂ ed i grassi a base di grafite non sono idonei. Le boccole SF-2 vengono impiegate in molteplici settori, tra i quali troviamo: industria mineraria e metallurgica, presse per lo stampaggio, macchine idroelettriche e per la laminazione a freddo dell'acciaio; generalmente applicazioni con lubrificazioni periodiche. L'utilizzo di questo tipo di boccole è in forte crescita proprio perché grazie alle principali caratteristiche, di seguito elencate, favorisce l'eliminazione di diversi problemi:

- scarsa manutenzione, dovuta ai larghi intervalli di rilubrificazione
- buona adattabilità ai movimenti oscillanti e rotativi
- usura limitata (se applicate ed utilizzate correttamente)
- idrorepellenti
- ridotta sensibilità al carico sugli spigoli
- buona dispersione del calore.

2.1 SF-2 structure

The porous bronze layer is sintered on the steel backing and has the function of bonding the sliding surface in polyacetalic resin and permitting thermal dispersion which presents sockets for collecting and gradually releasing the lubricant in order to reduce friction and protect the surface from the running of the bushing. In order to facilitate re-lubrication, the SF-2 bushings are furnished with an external hole for that purpose. It is recommended to use a grease with lino soap, on the contrary MoS₂ and grease with a graphite base are NOT suitable.

The SF-2 bushings have uses in multiple sectors, among which we find: mining industry and metallurgies, printing presses, hydroelectric machines and for cold lamination of steel; generally applications with periodic lubrication.

The use of this type of bushing is growing rapidly thanks to its principal characteristics listed as follows, which favour the elimination of diverse problems.

- low maintenance, due to long intervals of re-lubrication
- good adaptability to oscillating and rotating movements
- limited wear (if applied and used correctly)
- water repellent
- reduced sensibility to the loading on the edges
- good heat dispersion.

2.2 Caratteristiche tecniche

2.2 Technical features

Capacità di carico	70N/mm ²	Load capacity	70N/mm ²
Velocità limite v max	2,5 m/s	Speed limit v max	2,5 m/s
Temperatura limite	-40 °C ~ +110 °C	Temperature limit	-40 °C ~ +110 °C
Coefficiente di attrito a secco	μ: 0,05~0,25	Friction coefficient dry	μ: 0,05~0,25
Limite Pv	22N/mm ² • m/s	Pv limit	22N/mm ² • m/s

2.3 Prova di durata

La durata delle boccole SF-2 dipende soprattutto dal fattore di carico Pv, difficilmente determinabile inizialmente. Esistono infatti altri elementi che possono influenzare la durata, facendola pertanto aumentare o diminuire.

Questi elementi possono essere: la temperatura, il grado di finitura dell'albero, l'allineamento nell'accoppiamento, la lubrificazione... infatti nonostante le boccole SF-2, proprio grazie alla loro superficie alveolata, siano in grado di trattenere più lubrificante e richiedano poca manutenzione rispetto alle boccole del tipo SF-1, devono però essere periodicamente rilubrificate, perché così facendo possono garantire una durata maggiore. Fino a quando il lubrificante è ben distribuito sulla superficie di strisciamento, l'usura rimane abbastanza contenuta, anche in presenza di carichi specifici fino a 140 N/mm²; nel momento in cui il lubrificante viene a mancare, l'usura aumenta notevolmente. Ecco perché risulta importante effettuare la rilubrificazione prima che inizi la fase di usura.

Nella (fig. 4) sotto riportata, la linea B indica la durata dell'intervallo di rilubrificazione mentre la linea A la durata del materiale SF-2.

2.3 Durability test

The life of SF-2 bushing depends especially on the factor Pv, which is difficult to calculate, because it depends on several and environmental factors which can increase or decrease the operating life.

These elements can be: the temperature, the finishing grade of the shaft, the alignment, the lubrication... SF-2 bushings, thanks to their honey cones surface, can capture and retain more lubricants and require little maintenance compared to SF-1 type bushings, but they must be periodically re-lubricated in order to guarantee a much longer duration.

Once the lubricant has been distributed on the sliding surface, the wear remains relatively contained, even in the presence of specific loads up to 140 N/mm²; when the lubricant starts to decrease, the wear increases noticeably. That's why it is so important to re-lubricate before the wearing process begins.

In the (fig. 4) below, line B indicates the duration of the interval of re-lubrication while line A the duration of the SF-2 material.

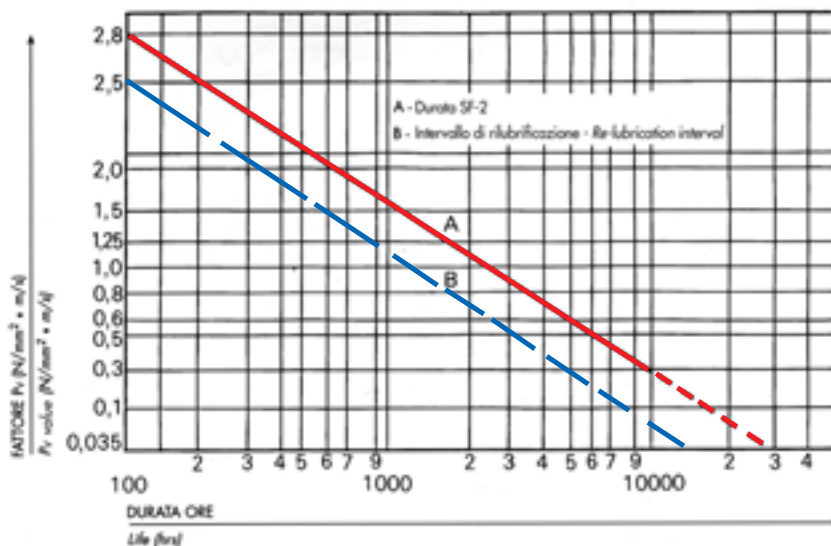

Fig. 4

Quando la boccia raggiunge dei valori d'usura pari a 0,15 mm è da intendersi esaurita e pertanto andrebbe sostituita.

When the bushing reaches wear values equal to 0,15 mm it is considered depleted and therefore to be substituted.

SF-2

Diametro esterno Outer diameter D	Tolleranze diametro esterno Outer diameter tolerances D	Tolleranze spessore Thickness tolerances S _B		Dimensioni smusso Chamfer dimensions S _B f ₁ f ₂		
		≤ 10	+ 0,055 + 0,025	1	- 0,020 - 0,045	1
10 < ≤ 18	+ 0,065 + 0,030	1	- 0,020 - 0,045	1	0,6 ± 0,4	- 0,1 - 0,4
18 < ≤ 30	+ 0,075 + 0,035	1,5	- 0,025 - 0,055	1,5	0,6 ± 0,4	- 0,1 - 0,6
30 < ≤ 50	+ 0,085 + 0,045	2	- 0,030 - 0,065	2	1,2 ± 0,4	- 0,1 - 0,7
50 < ≤ 80	+ 0,100 + 0,055	2,5	- 0,040 - 0,085	2,5	1,8 ± 0,6	- 0,2 - 1,0
80 < ≤ 120	+ 0,120 + 0,070	2,5	- 0,040 - 0,085	2,5	1,8 ± 0,6	- 0,2 - 1,0
120 < ≤ 180	+ 0,170 + 0,100	2,5	- 0,040 - 0,085	2,5	1,8 ± 0,6	- 0,2 - 1,0
180 < ≤ 305	+ 0,255 + 0,125	2,5	- 0,040 - 0,085	2,5	1,8 ± 0,6	- 0,2 - 1,0

Le tolleranze delle boccole metriche SF-2 rispettano la norma
ISO 3547-1:2006

Tolerance values of metric bushings SF-2 comply with standard
ISO 3547-1:2006



mayoral

Tolleranze di montaggio raccomandate / Recommended mounting tolerances: **Suministros Industriales y Servicios**

Albero: h 8	Foro: ≤ 4 = H 6 > 4 = H 7	Shaft: h 8	Bore: ≤ 4 = H 6 > 4 = H 7
----------------	---------------------------------	---------------	---------------------------------

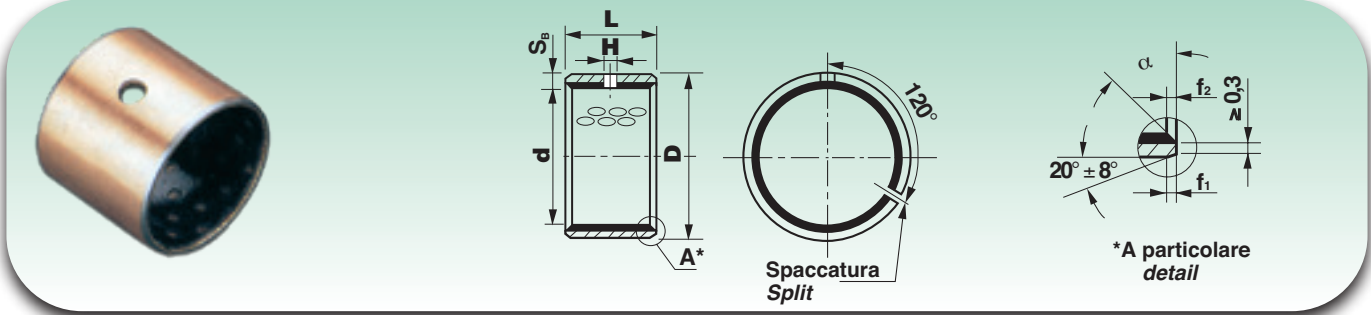

Dimensioni (mm) Dimensions (mm)			
d	D	L ^{±0,25}	H min
6	8	8	⊛
		10	
7	9	10	⊛
8	10	8	3
		10	
		12	
10	12	8	3
		10	
		12	
		15	
		20	
12	14	10	3
		12	
		15	
		20	
13	15	10	3
		14	
14	16	15	3
		20	
		22	
		25	
		32	
		10	
15	17	12	3
		15	
		20	
		25	
16	18	10	3
		12	
		15	
		16	
		20	
		25	
17	19	12	3
		20	
18	20	15	3
		18	
		20	
		25	
20	23	10	3
		12	
		15	
		17	
		20	
		25	
22	25	15	3
		20	
		22	
		25	
		30	

Dimensioni (mm) Dimensions (mm)			
d	D	L ^{±0,25}	H min
24	27	15	4
		20	
		25	
		30	
25	28	10	4
		15	
		20	
		25	
		30	
		40	
28	31	30	4
28	32	20	4
		25	
		28	
		30	
		15	
30	34	20	4
		25	
		30	
		40	
32	36	30	4
35	39	35	4
		40	
		15	
		20	
		25	
		30	
36	40	35	4
		60	
		20	
		30	
37	41	20	4
		30	
40	44	20	4
		25	
		30	
		40	
		50	
		40	
45	50	20	5
		25	
		30	
		35	
		40	
		45	
50	55	20	5
		25	
		30	
		30	

Dimensioni (mm) Dimensions (mm)			
d	D	L ^{±0,25}	H min
50	55	40	5
		50	
		55	
		60	
55	60	20	6
		25	
		30	
		40	
		50	
		55	
60	65	30	6
		40	
		50	
		60	
		70	
65	70	30	6
		40	
		50	
		60	
		65	
		70	
70	75	50	6
		60	
		65	
		70	
75	80	40	6
		60	
		75	
		80	
80	85	40	6
		50	
		55	
		60	
		70	
		80	
85	90	30	6
		40	
		50	
		60	
		80	
		85	
90	95	40	6
		60	
		80	
		90	
100	100	100	6
		100	

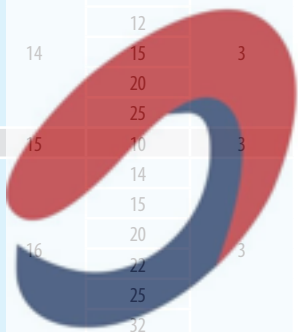

mayoral
Suministros Industriales y Servicios

⊛ senza foro di lubrificazione - without lubrication hole

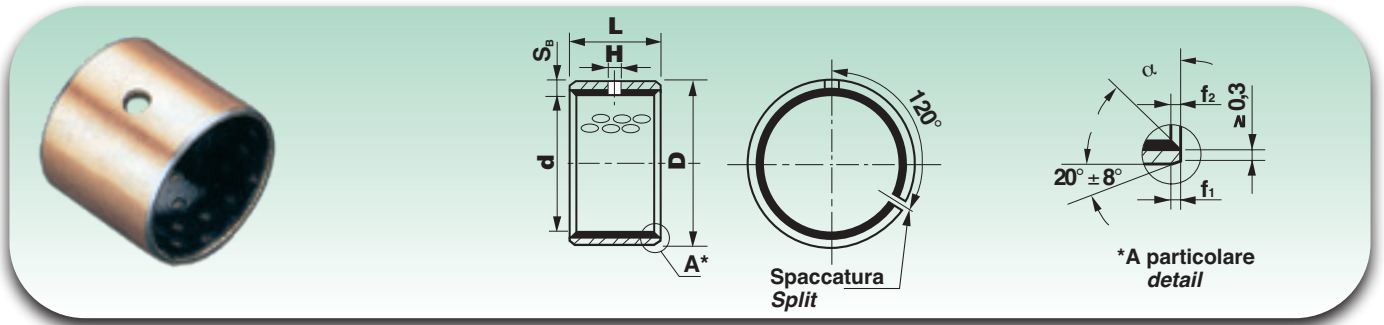

Dimensioni (mm) Dimensions (mm)			
d	D	L ^{±0,25}	H min
95	100	30	6
		60	
		90	
		100	
100	105	30	6
100	105	40	6
		50	
		60	
		80	
		90	
		95	
		100	
105	110	50	7
		60	
		80	
		95	
		105	
		110	
110	115	30	7
		50	
		60	
		80	
		95	
115	120	50	7
120	125	40	7
		60	
		80	
		100	
		110	
125	130	120	7
		50	
		60	
		80	
		100	
		110	
125			

Dimensioni (mm) Dimensions (mm)			
d	D	L ^{±0,25}	H min
130	135	50	7
		60	
		80	
		100	
		130	
		140	
135	140	30	7
		60	
		80	
		100	
140	145	80	7
150	155	50	7
		60	
		80	
		100	
		130	
		140	
170	175	60	7
		80	
		100	
		170	
180	185	50	7
		60	
		80	
		100	
		180	
190	195	50	7
		60	
		80	
		100	
		120	
		190	
200	205	50	7
		60	

Dimensioni (mm) Dimensions (mm)			
d	D	L ^{±0,25}	H min
200	205	80	7
		100	
		120	
		200	
		220	
220	225	50	7
		60	
		80	
		100	
		120	
		220	
240	245	50	7
		60	
		80	
		100	
		120	
250	255	50	7
		60	
		80	
		100	
260	265	80	7
		100	
		120	
		260	
		280	
280	285	50	7
		60	
		80	
		100	
		120	
		280	
300	305	50	7
		60	
		80	
		100	
		120	
		300	
-	-	-	-

Per ordinare specificare: SF-2 + d + L

To order, please specify: SF-2 + d + L

Possono essere fornite boccole a disegno per quantità

Bushings made according drawings can be supplied if large quantities are ordered.

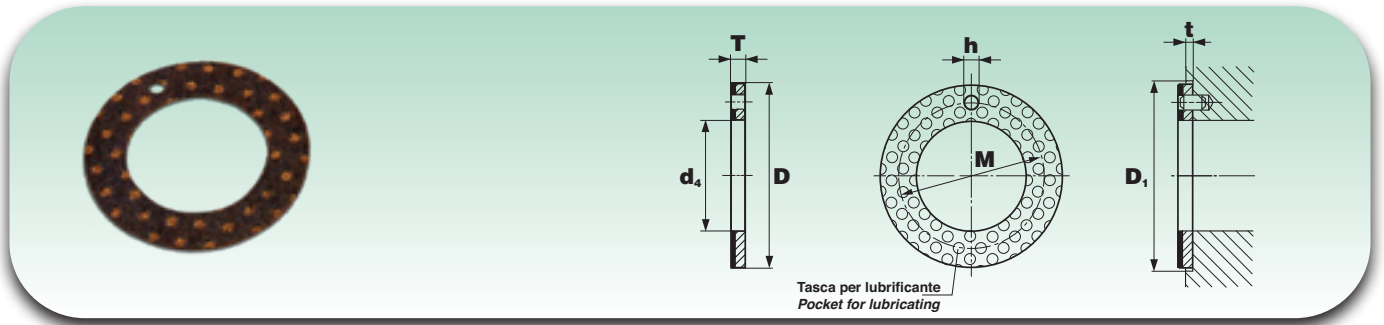

Sigla Designation	Dimensioni (mm) Dimensions (mm)				Dimensioni di montaggio (mm) Mounting dimensions (mm)		
	$d_4^{+0,25}$	$D^{-0,25}$	$T^{-0,05}$	$M^{\pm 0,15}$	$h^{+0,4/+0,1}$	$t^{\pm 0,2}$	$D_1^{+0,12}$
WC-2 9	9	19	1	14	2	0,5	19
WC-2 10	10	20	1,5	15	1,5	1	20
WC-2 12	12	24	1,5	18	1,5	1	24
WC-2 14	14	26	1,5	20	2	1	26
WC-2 15	15	28	1	21,5	2	1	28
WC-2 16	16	30	1,5	23	2	1	30
WC-2 18	18	32	1,5	25	2	1	32
WC-2 20	20	36	1,5	28	3	1	36
WC-2 22	22	38	1,5	30	3	1	38
WC-2 24	24	42	1,5	33	3	1	42
WC-2 26	26	44	1,5	35	3	1	44
WC-2 28	28	48	1,5	38	4	1	48
WC-2 30	30	52	1,5	41	4	1	52
WC-2 32	32	54	1,5	43	4	1	54
WC-2 35	35	58	1,5	46,5	4	1	58
WC-2 38	38	62	1,5	50	4	1	62
WC-2 42	42	66	1,5	54	4	1	66
WC-2 45	45	70	1,5	57,5	4	1	70
WC-2 48	48	74	2	61	4	1,5	74
WC-2 50	50	76	2	63	4	1,5	76
WC-2 52	52	78	2	65	4	1,5	78
WC-2 60	60	90	2	75	5	1,5	90
WC-2 62	62	90	2	76	4	1,5	90

Per ordinare specificare: sigla
To order, please specify: designation
Le tolleranze riportate in questa pagina rispettano la norma ISO 6525:1983
The tolerance values given on this page comply with standard ISO 6525:1983
Su richiesta disponibili:

• senza foro

On request, available also:

• without hole

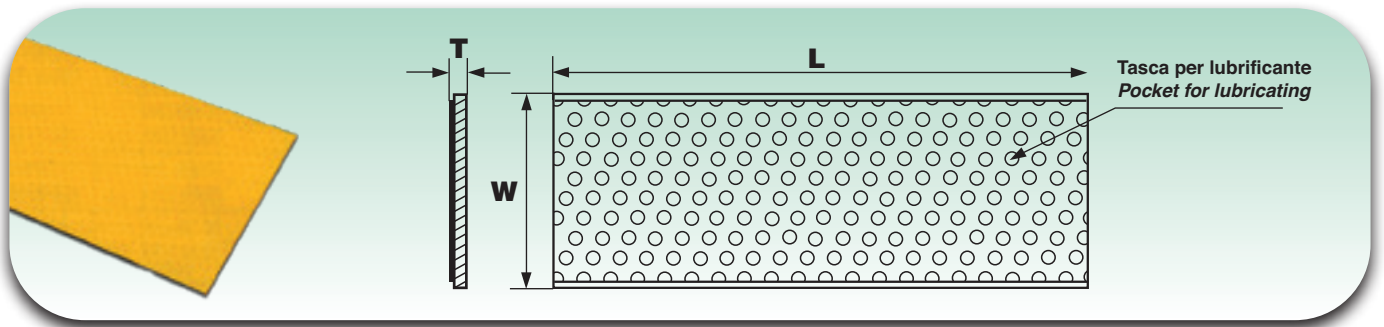

Sigla <i>Designation</i>	Dimensioni (mm) - <i>Dimensions (mm)</i>		
	Lunghezza <i>Length</i> L ± 1	Altezza <i>Width</i> W ± 1	Spessore <i>Thickness</i> T $-0,05$
NSTR-1 10120	500	120	0,99
NSTR-1 10125	500	125	1,0
NSTR-1 10180	500	180	0,99
NSTR-1 10180	500	180	1,0
NSTR-1 15180	500	180	1,48
NSTR-1 20180	500	180	1,97
NSTR-1 25180	500	180	2,46
NSTR-1 25200	500	200	2,5
NSTR-1 30200	500	200	3,0

Per ordinare specificare: sigla

To order, please specify: designation



mayoral
Suministros Industriales y Servicios

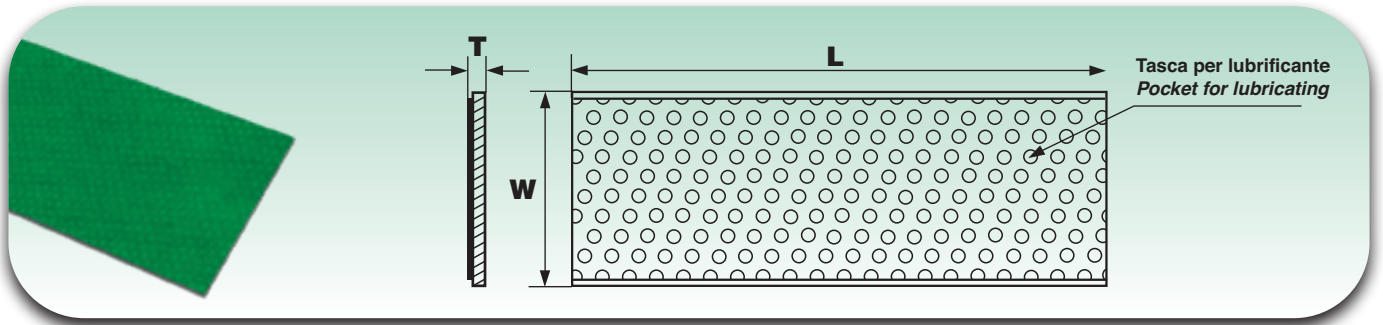

Sigla <i>Designation</i>	Dimensioni (mm) - <i>Dimensions (mm)</i>		
	Lunghezza <i>Length</i> $L^{\pm 1}$	Altezza <i>Width</i> $W^{\pm 1}$	Spessore <i>Thickness</i> $T^{-0,05}$
NSTR-2 10120	500	120	1,11
NSTR-2 10180	500	180	1,11
NSTR-2 15180	500	180	1,61
NSTR-2 20180	500	180	2,11
NSTR-2 25180	500	180	2,63

Per ordinare specificare: sigla

To order, please specify: designation



mayoral
Suministros Industriales y Servicios

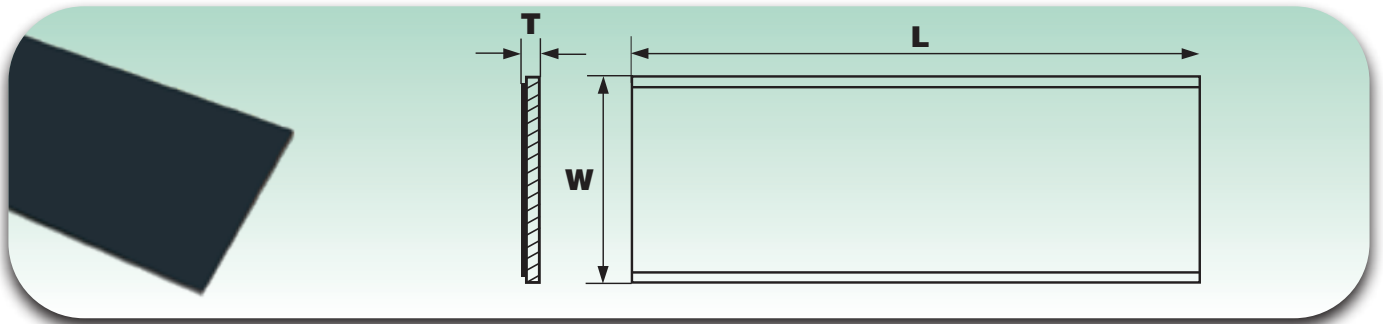

Sigla <i>Designation</i>	Dimensioni (mm) - <i>Dimensions (mm)</i>		
	Lunghezza <i>Length</i> L ^{±1}	Altezza <i>Width</i> W ^{±1}	Spessore <i>Thickness</i> T ^{-0,05}
NSTR-3 10120	500	120	1,11
NSTR-3 10180	500	180	1,11
NSTR-3 15180	500	180	1,61
NSTR-3 20180	500	180	2,11
NSTR-3 25180	500	180	2,63

Per ordinare specificare: sigla

To order, please specify: designation



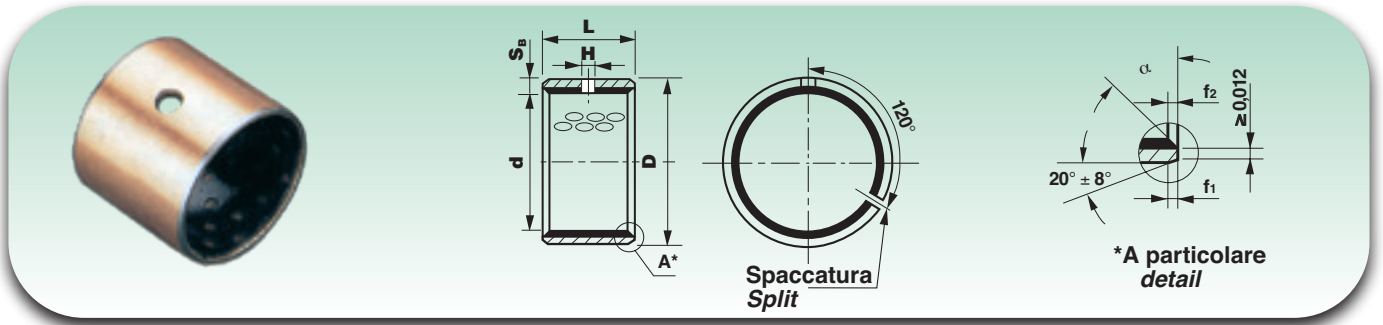

Sigla Designation	Dimensioni (pollici/mm) Dimensions (inches/mm)							
	d		D		L $\pm 0,010''$		H	
	inch.	mm	inch.	mm	inch.	mm	inch.	mm
3/8 - 3/8	3/8	9,53	15/32	11,91	3/8	9,53	5/32	3,97
3/8 - 1/2					1/2	12,70		
3/8 - 3/4					3/4	19,05		
7/16 - 1/2	7/16	11,11	17/32	13,49	1/2	12,70	5/32	3,97
7/16 - 3/4					3/4	19,05		
1/2 - 3/8					3/8	9,53		
1/2 - 1/2	1/2	12,70	19/32	15,08	1/2	12,70	5/32	3,97
1/2 - 5/8					5/8	15,88		
1/2 - 7/8					7/8	22,23		
9/16 - 1/2	9/16	14,29	21/32	16,67	1/2	12,70	5/32	3,97
9/16 - 3/4					3/4	19,05		
5/8 - 1/2					1/2	12,70		
5/8 - 5/8	5/8	15,88	23/32	18,26	5/8	15,88	5/32	3,97
5/8 - 3/4					3/4	19,05		
5/8 - 7/8					7/8	22,23		
11/16 - 7/8	11/16	17,46	25/32	19,84	7/8	22,23	5/32	3,97
3/4 - 1/2					1/2	12,70		
3/4 - 3/4					3/4	19,05		
3/4 - 1	3/4	19,05	7/8	22,23	1	25,40	5/32	3,97
7/8 - 3/4					3/4	19,05		
7/8 - 7/8					7/8	22,23		
7/8 - 1	7/8	22,23	1	25,40	1	25,40	3/32	3,97
1 - 3/4					3/4	19,05		
1 - 1					1	25,40		
1 - 1 1/2	1	25,40	1 1/8	28,58	1 1/2	38,10	5/32	3,97
1 1/8 - 3/4					3/4	19,05		
1 1/8 - 1					1	25,40		
1 1/4 - 3/4	1 1/4	31,75	1 13/32	35,72	3/4	19,05	1/4	6,35
1 1/4 - 1					1	25,40		
1 1/4 - 1 1/4					1 1/4	31,75		
1 1/4 - 1 3/4	1 1/4	31,75	1 13/32	35,72	1 3/4	44,45	1/4	6,35
1 3/8 - 1					1	25,40		
1 3/8 - 1 3/8					1 3/8	34,93		
1 3/8 - 1 1/2	1 3/8	34,93	1 17/32	38,89	1 1/2	38,10	1/4	6,35
1 3/8 - 1 3/4					1 3/4	44,45		
1 1/2 - 1					1	25,40		
1 1/2 - 1 1/4	1 1/2	38,10	1 21/32	42,07	1 1/4	31,75	1/4	6,35
1 1/2 - 1 1/2					1 1/2	38,10		

Per ordinare specificare: SF-2 + sigla

To order, please specify: SF-2 + designation

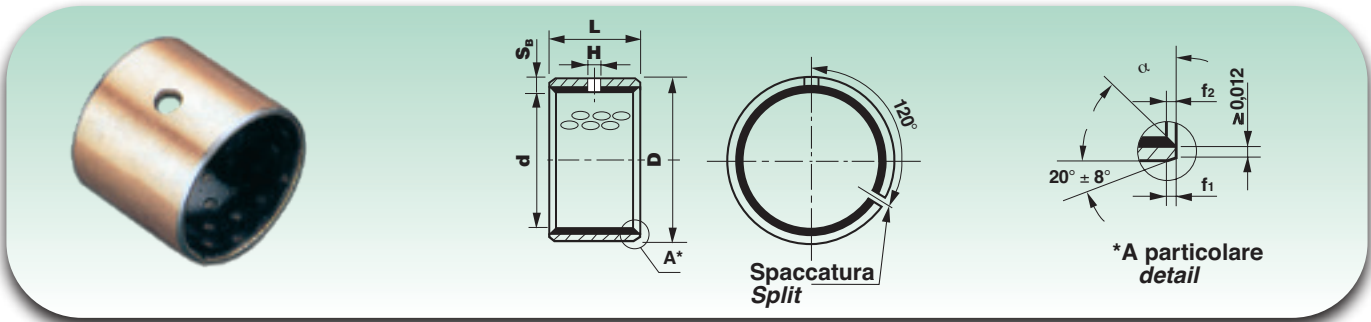

Sigla Designation	Dimensioni (pollici/mm) Dimensions (inches/mm)							
	d		D		L ±0,010"		H	
	inch.	mm	inch.	mm	inch.	mm	inch.	mm
1 1/2 - 2	1 1/2	38,10	1 25/32	42,07	2	50,80	1/4	6,35
1 5/8 - 1	1 5/8	41,28	1 25/32	45,24	1	25,40	1/4	6,35
1 5/8 - 1 1/2					1 1/2	38,10		
1 5/8 - 2					2	50,80		
1 3/4 - 1	1 3/4	44,45	1 15/16	49,21	1	25,40	1/4	6,35
1 3/4 - 1 1/2					1 1/2	38,10		
1 3/4 - 1 3/4					1 3/4	44,45		
1 3/4 - 2					2	50,80		
1 7/8 - 1	1 7/8	47,63	2 1/16	52,39	1	25,40	1/4	6,35
1 7/8 - 1 1/2					1 1/2	38,10		
1 7/8 - 1 7/8					1 7/8	47,63		
1 7/8 - 2					2	50,80		
1 7/8 - 2 1/4					2 1/4	57,15		
2 - 1					2	50,80		
2 - 1 1/2	2	50,80	2 3/4	55,56	1 1/2	38,10	5/16	7,94
2 - 2					2	50,80		
2 - 2 1/2	2 1/4	57,15	2 7/16	61,91	2 1/2	63,50	5/16	7,94
2 1/4 - 2					2	50,80		
2 1/4 - 2 1/4					2 1/4	57,15		
2 1/4 - 2 1/2	2 1/4	63,50	2 11/16	68,26	1 1/2	38,10	5/16	7,94
2 1/2 - 1 1/2					2	50,80		
2 1/2 - 2	2 3/4	69,85	2 15/16	74,61	2 1/2	63,50	5/16	7,94
2 1/2 - 2 1/2					2 1/2	63,50		
2 3/4 - 2					2	50,80		
2 3/4 - 2 1/2	2 3/4	69,85	2 15/16	74,61	3	76,20	5/16	7,94
2 3/4 - 3					3 1/2	88,90		
2 3/4 - 3 1/2					3 1/2	88,90		
3 - 1 1/2	3	76,20	3 3/16	80,96	1 1/2	38,10	3/8	9,53
3 - 2					2	50,80		
3 - 2 1/2					2 1/2	63,50		
3 - 3					3	76,20		
3 - 3 3/4					3 3/4	95,25		
3 1/2 - 2 1/2	3 1/2	88,90	3 11/16	93,66	2 1/2	63,50	3/8	9,53
3 1/2 - 3					3	76,20		
3 1/2 - 3 3/4					3 3/4	95,25		
4 - 3	4	101,60	4 3/16	106,36	3	76,20	3/8	9,53
4 - 3 3/4					3 3/4	95,25		
4 - 4 3/4					4 3/4	120,65		

Per ordinare specificare: SF-2 + sigla

To order, please specify: SF-2 + designation

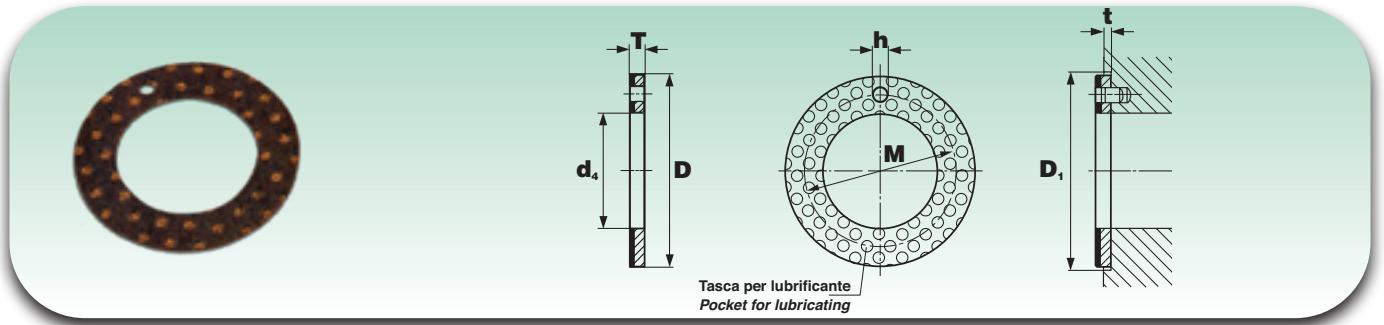

Sigla Designation	Dimensioni (pollici/mm) Dimensions (inches/mm)								Dimensioni di montaggio (pollici/mm) Mounting dimensions (inches/mm)					
	$d_4^{+0,010''}$		$D^{-0,010''}$		$T^{+0,0035''}$		$M^{-0,010''}$		$h^{+0,010''}$		$t^{+0,010''}$		$D_1^{+0,010''}$	
	inch.	mm	inch.	mm	inch.	mm	inch.	mm	inch.	mm	inch.	mm	inch.	mm
WC-2 0500	0,500	12,70	0,875	22,23	0,066	1,676	0,692	17,58	0,067	1,70	0,04	1,02	0,875	22,23
WC-2 0562	0,562	14,27	1,000	25,40	0,066	1,676	0,786	19,96	0,067	1,70	0,04	1,02	1,000	25,40
WC-2 0625	0,625	15,88	1,125	28,58	0,066	1,676	0,880	22,35	0,099	2,51	0,04	1,02	1,125	28,58
WC-2 0687	0,687	17,45	1,187	30,15	0,066	1,676	0,942	23,93	0,099	2,51	0,04	1,02	1,187	30,15
WC-2 0750	0,750	19,05	1,250	31,75	0,066	1,676	1,005	25,53	0,099	2,51	0,04	1,02	1,250	31,75
WC-2 0812	0,812	20,62	1,375	34,93	0,066	1,676	1,009	27,91	0,099	2,51	0,04	1,02	1,375	34,93
WC-2 0875	0,875	22,23	1,500	38,10	0,066	1,676	1,192	30,28	0,130	3,30	0,04	1,02	1,500	38,10
WC-2 0937	0,937	23,80	1,625	41,28	0,066	1,676	1,286	32,66	0,130	3,30	0,04	1,02	1,625	41,28
WC-2 1000	1,000	25,40	1,750	44,45	0,066	1,676	1,380	35,05	0,130	3,30	0,04	1,02	1,750	44,45
WC-2 1125	1,125	28,58	2,000	50,80	0,066	1,676	1,567	39,80	0,161	4,09	0,04	1,02	2,000	50,80
WC-2 1250	1,250	31,75	2,125	53,98	0,066	1,676	1,692	42,98	0,161	4,09	0,04	1,02	2,125	53,98
WC-2 1375	1,375	34,93	2,250	57,15	0,066	1,676	1,817	46,15	0,161	4,09	0,04	1,02	2,250	57,15
WC-2 1500	1,500	38,10	2,500	63,50	0,066	1,676	2,005	50,93	0,192	4,88	0,04	1,02	2,500	63,50
WC-2 1625	1,625	41,28	2,625	66,68	0,066	1,676	2,130	54,10	0,192	4,88	0,04	1,02	2,625	66,68
WC-2 1750	1,750	44,45	2,750	69,85	0,066	1,676	2,255	57,28	0,192	4,88	0,04	1,02	2,750	69,85
WC-2 2000	2,000	50,80	3,000	76,20	0,097	2,464	2,505	63,63	0,192	4,88	0,07	1,78	3,000	76,20
WC-2 2125	2,125	53,98	3,125	79,38	0,097	2,464	2,630	66,80	0,192	4,88	0,07	1,78	3,125	79,38
WC-2 2250	2,250	57,15	3,250	82,55	0,097	2,464	2,755	69,98	0,192	4,88	0,07	1,78	3,250	82,55



Per ordinare specificare: sigla

To order, please specify: designation

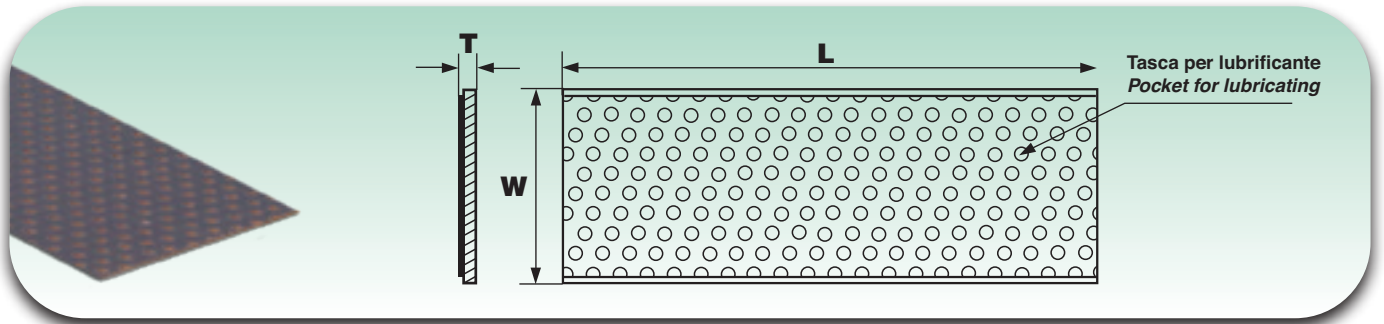

Sigla Designation	Dimensioni (mm) - Dimensions (mm)					
	Lunghezza Length $L^{+0,2''}$		Altezza Width $W^{+0,1''}$		Spessore Thickness $T^{-0,0035}$	
	inch.	mm	inch.	mm	inch.	mm
NSTR-I 00492	19,69	500,13	2,75	69,85	0,0492	1,2497
NSTR-I 00642	19,69	500,13	4,00	101,60	0,0642	1,6307
NSTR-I 00795	19,69	500,13	4,00	101,60	0,0795	2,0193
NSTR-I 00949	19,69	500,13	4,00	101,60	0,0949	2,4105

Per ordinare specificare: sigla

To order, please specify: designation



Su richiesta disponibili:

- con rivestimento in bronzo (NSTR-IB)
- versione 090 (NSTR 090)

On request, available also:

- with bronze covering (NSTR-IB)
- 090 version (NSTR 090)



mayoral[®]

Suministros Industriales y Servicios

3. Caratteristiche boccole sinterizzate BNZ e FE

Il programma **ISB**® prevede un'ampia gamma di boccole realizzate in materiale sinterizzato (bronzo, ferro e bronzo grafite compatto), disponibili in formato cilindrico e flangiato.

Grazie alla particolare struttura porosa della superficie, dopo la prima oliatura da parte del costruttore, che permette il rilascio graduale del lubrificante, le boccole possono essere utilizzate senza manutenzione per lunghi periodi.

Le boccole in ferro rispetto a quelle in bronzo, sono adatte per sopportare carichi più elevati in presenza di un numero di giri inferiore. Le boccole in bronzo sono invece adatte per ambienti molto polverosi, dove non è possibile la presenza d'olio; sono indicate anche per applicazioni a contatto d'acqua o con liquidi compatibili con il bronzo. Le boccole sinterizzate trovano il loro maggior impiego nelle macchine elettriche, negli utensili elettrici, macchine tessili, nell'industria chimica, macchine per ufficio e nell'industria automobilistica.

3.1 Materiale

Le boccole in bronzo sinterizzato ISB possono essere realizzate in SINT A51, un materiale composto da una matrice in bronzo metallico sinterizzato e grafite, presente in circa 1% del peso. Il materiale di base di queste boccole, poroso ed impregnato di olio minerale, migliora le caratteristiche di antifrizione, specialmente in condizioni di **scarsa lubrificazione**.

Si riportano di seguito le caratteristiche e la composizione chimica:

- Capacità di carico: 35 N/mm²
- Limite Pv: 1.6 N/mm² x m/s
- Velocità limite: 5 m/s
- Temperatura limite: da -20°C / +120 °C
- Contenuto d'olio: min. 18% vol.
- Coefficiente d'attrito a secco μ : 0.10 – 0.18
- Coefficiente d'attrito ingrassata μ : 0.05 – 0.10

3. BNZ and FE sintered bushings characteristics

ISB® provides an ample range of bushings realized in sintered materials (bronze, iron, compact bronze graphite), available both in cylindrical and flanged formats. Thanks to the particular porous structure of the surface, after the first oiling done by the constructor, which permits the gradual release of the lubricant, the bushings can be used without maintenance for long periods.

The iron bushings compared to those in bronze, can bear heavier loads with lower rotational speed. The bushings in bronze are on the other hand adapt for very dusty ambients where oil can not be used; they are indicated even for applications in contact with water or other bronze compatible liquids.

The sintered bushings are mainly used in electric machines, in electric tools, textile machines, in the chemical industry, office machines and in the automobile industry.

3.1 Material

ISB sintered bronze bushings may be made of SINT A51, a material composed of a matrix of sintered metallic bronze and graphite, present in about 1% of the weight. The basic material of these bushings, porous and impregnated with mineral oil, improves the anti-friction characteristics especially in conditions of **poor lubrication**.

The characteristics and chemical composition are reported below:

- Load capacity: 35 N/mm²
- Pv limit: 1.6 N/mm² x m/s
- Speed Limit: 5 m/s
- Limit temperature: from -20°C / +120 °C
- Oil content: min. 18% vol.
- Dry friction coefficient μ : 0.10 – 0.18
- Greased friction coefficient μ : 0.05 – 0.10

mayoral
Suministros Industriales y Servicios

SINT A51				
Cu %	Sn %	Zn %	C %	Pb %
Base / Balance	9.0-11.0	≤ 2.0	0.5-3.0	-

Composizione	SINT A51	Composition	SINT A51
Capacità di carico	35N/mm ²	Load capacity	35N/mm ²
Temperatura limite	-20 °C ~ +120 °C	Temperature limit	-20 °C ~ +120 °C
Coefficiente di attrito a secco	μ : 0,10~0,18	Friction coefficient dry	μ : 0,10~0,18

Disponibili anche in:

Composizione	FE	Composition	FE
Capacità di carico	45N/mm ²	Load capacity	45N/mm ²
Temperatura limite	-80 °C ~ +160 °C	Temperature limit	-80 °C ~ +160 °C
Coefficiente di attrito a secco	μ : 0,15~0,20	Friction coefficient dry	μ : 0,15~0,20

BNZ/FE

Diametro interno <i>Inner diameter</i> d	Tolleranze diametro interno <i>Inner diameter tolerances</i> d	Diametro esterno <i>Outer diameter</i> D	Tolleranze diametro esterno <i>Outer diameter tolerances</i> D
≤ 3	+0,012 +0,002	3 < ≤ 6	+0,031 +0,019
3 < ≤ 6	+0,016 +0,004	6 < ≤ 10	+0,038 +0,023
6 < ≤ 10	+0,020 +0,005	10 < ≤ 18	+0,046 +0,028
10 < ≤ 18	+0,024 +0,006	18 < ≤ 30	+0,056 +0,035
18 < ≤ 30	+0,028 +0,007	30 < ≤ 50	+0,068 +0,043
30 < ≤ 50	+0,034 +0,009	50 < ≤ 65	+0,083 +0,053
50 < ≤ 80	+0,040 +0,010	65 < ≤ 80	+0,089 +0,059
80 < ≤ 120	+0,047 +0,012	80 < ≤ 100	+0,106 +0,071
120 < ≤ 180	+0,054 +0,014	100 < ≤ 120	+0,114 +0,079
-	-	120 < ≤ 140	+0,132 +0,092
-	-	140 < ≤ 160	+0,140 +0,100

BNZF/FEF

Tolleranze spessore <i>Thickness tolerances</i> S _B	Dimensioni smusso <i>Chamfer dimensions</i> S _B	Dimensioni raggio (mm) <i>Radius dimension (mm)</i> r _{max}	Tolleranze lunghezza, diametro flangia, spessore <i>Length, flange diameter, thickness tolerances</i> Dimensione Dimensione Tolleranza Tolerance
1 +0,020 +0,045	≤ 1	0,2	≤ 12 0,3 ≤ 3 ±0,07
1 +0,020 +0,045	1 < ≤ 2	0,3	12 < ≤ 30 0,6 3 < ≤ 6 ±0,09
1,5 +0,025 +0,055	2 < ≤ 3	0,4	> 30 0,8 6 < ≤ 10 ±0,11
2 +0,030 +0,065	3 < ≤ 4	0,6	- - 10 < ≤ 18 ±0,135
2,5 +0,040 +0,085	4 < ≤ 5	0,7	- - 18 < ≤ 30 ±0,165
2,5 +0,040 +0,085	> 5	0,8	- - 30 < ≤ 50 ±0,195
2,5 +0,040 +0,085	-	-	- - 50 < ≤ 80 ±0,230
2,5 +0,040 +0,085	-	-	- - 80 < ≤ 120 ±0,270

Le tolleranze delle boccole BNZ, BNZF, F2, FEF rispettano la norma ISO 2795:1991

Tolerance values of bushings BNZ, BNZF, FE and FEF comply with standard ISO 2795:1991

Tolleranze di montaggio raccomandate:

Recommended mounting tolerances:

Albero:
f7 - f8

Foro:
H 7

Shaft:
f7 - f8

Bore:
H 7

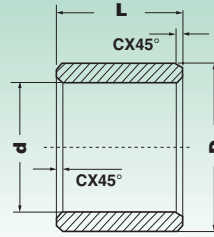

Dimensioni (mm) Dimensions (mm)					
d _(G7)	D _(s7)	L _(js13)	C _{max}		
2	5	2 ±0,070	0,3		
		3 ±0,070			
		4 ±0,090			
		5 ±0,090			
		6 ±0,090			
2,5	6	10 ±0,110	0,3		
3	6	3 ±0,070	0,3		
		4 ±0,090			
		5 ±0,090			
		6 ±0,090			
		7 ±0,110			
	8	8 ±0,110	0,4		
		10 ±0,110			
		6 ±0,090		0,2	
		7,5 ±0,090			
		8 ±0,110			
4	6,5	8,5 ±0,110	0,3		
		10 ±0,110			
		4 ±0,090		0,2	
		3 ±0,070			
		4 ±0,090			
	7	7	6 ±0,090		0,3
			7 ±0,110		
			8 ±0,110		
			10 ±0,110		
			12 ±0,135		
8		8	4 ±0,090	0,3	
			5 ±0,090		
			6 ±0,090		
			8 ±0,110		
			10 ±0,110		
	10	12 ±0,135	0,4		
		15 ±0,135			
		16 ±0,135			
		4 ±0,090		0,3	
		5 ±0,090			
8 ±0,110					
10 ±0,110					
12 ±0,135					
5	8	15 ±0,135	0,3		
		16 ±0,135			
		4 ±0,090		0,3	
		5 ±0,090			
		6,5 ±0,090			
	9	8 ±0,110	0,3		
		9 ±0,110			
		10 ±0,110			
		11 ±0,110			
		13 ±0,135			

Dimensioni (mm) Dimensions (mm)				
d _(G7)	D _(s7)	L _(js13)	C _{max}	
5	10	5 ±0,090	0,4	
		8 ±0,110		
		10 ±0,110		
		12 ±0,135		
		14 ±0,135		
		15 ±0,135		
		5 ±0,090		0,2
8 ±0,110				
9,5 ±0,110				
10 ±0,110				
8 ±0,110	0,3			
8,5				
6	10	4 ±0,090	0,3	
		6 ±0,090		
		8 ±0,110		
		9 ±0,110		
		10 ±0,110		
	12	12 ±0,135	0,4	
		15 ±0,135		
		16 ±0,135		
		5 ±0,090		0,3
		6 ±0,090		
8 ±0,110				
10 ±0,110				
12 ±0,135				
7	10	15 ±0,135	0,6	
		16 ±0,135		
		25 ±0,165		
	13	15 ±0,135	0,6	
		14 ±0,135		
	10	5 ±0,090	0,3	
		6 ±0,090		
8 ±0,110				
10 ±0,110				
12 ±0,135				
11	6 ±0,090	0,3		
	8 ±0,110			
	10 ±0,110			
12	13 ±0,135	0,4		
	8,5 ±0,110			

Dimensioni (mm) Dimensions (mm)				
d _(G7)	D _(s7)	L _(js13)	C _{max}	
7	13	13 ±0,135	0,4	
		22 ±0,165		
10	14	10 ±0,110	0,6	
		5 ±0,090		0,2
		6 ±0,090		
		8 ±0,110		
		10 ±0,110		
11	11	12 ±0,135	0,3	
		16 ±0,135		
		20 ±0,165		
		5 ±0,090		0,3
		6 ±0,090		
8 ±0,110				
10 ±0,110				
12 ±0,135				
8,15	14	12 ±0,135	0,4	
		14 ±0,135		
		15 ±0,135		
		16 ±0,135		
		20 ±0,165		
	15	8 ±0,110	0,6	
		10 ±0,110		
		12 ±0,135		
		14 ±0,135		
		15 ±0,135		
16	6 ±0,090	0,6		
	12 ±0,135			
	10 ±0,110		0,3	
	18 ±0,135			
	25 ±0,165			
9	12	12 ±0,135		0,3
		6 ±0,090		
		10 ±0,110		
		14 ±0,135		
		16 ±0,135		
13	13 ±0,135	0,3		
	5 ±0,090		0,4	
	6 ±0,090			
	8 ±0,110			
	10 ±0,110			
14	14	12 ±0,135		0,4
		14 ±0,135		
		12 ±0,135		
		14 ±0,135		
		15 ±0,135		

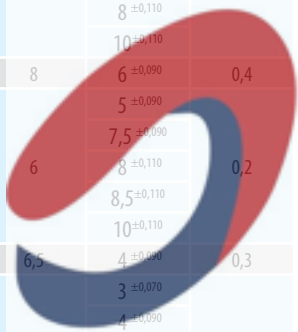

mayoral
Suministros Industriales y Servicios

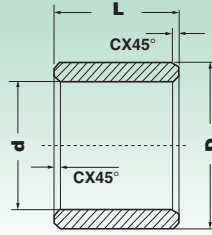

Dimensioni (mm) Dimensions (mm)				
d _(G7)	D _(s7)	L _(js13)	C _{max}	
9	14	16 ^{±0,135}	0,4	
		20 ^{±0,165}		
10	12	10 ^{±0,110}	0,2	
		12 ^{±0,135}		
		14 ^{±0,135}		
		18 ^{±0,135}		
		10 ^{±0,110}		
	13	12 ^{±0,135}	0,3	
		15 ^{±0,135}		
		16 ^{±0,135}		
	14	13	18 ^{±0,135}	0,3
			20 ^{±0,165}	
			25 ^{±0,165}	
			5 ^{±0,090}	
8 ^{±0,110}				
14		10 ^{±0,110}	0,3	
		12 ^{±0,135}		
		14 ^{±0,135}		
		15 ^{±0,135}		
		16 ^{±0,135}		
10	14	18 ^{±0,135}	0,3	
		20 ^{±0,165}		
		25 ^{±0,165}		
	15	10 ^{±0,110}	0,4	
		12 ^{±0,135}		
		15 ^{±0,135}		
		16 ^{±0,135}		
		20 ^{±0,165}		
	16	8 ^{±0,110}	0,4	
		10 ^{±0,110}		
		12 ^{±0,135}		
		15 ^{±0,135}		
		16 ^{±0,135}		
		20 ^{±0,165}		
		32 ^{±0,195}		
18	10 ^{±0,110}	0,6		
	12 ^{±0,135}			
	15 ^{±0,135}			
	20 ^{±0,165}			
11	16	20 ^{±0,165}	0,4	
		25 ^{±0,165}	0,6	
12	14	10 ^{±0,110}	0,2	
		12 ^{±0,135}		
		15 ^{±0,135}		
		16 ^{±0,135}		
	15	20 ^{±0,165}	0,3	
		12 ^{±0,135}		

Dimensioni (mm) Dimensions (mm)				
d _(G7)	D _(s7)	L _(js13)	C _{max}	
10	15	12,5 ^{±0,135}	0,3	
		12,8 ^{±0,135}		
		13 ^{±0,135}		
		15 ^{±0,135}		
		16 ^{±0,135}		
		18 ^{±0,135}		
		20 ^{±0,165}		
		25 ^{±0,165}		
		7 ^{±0,110}		0,3
		8 ^{±0,110}		
12	16	10 ^{±0,110}	0,3	
		11 ^{±0,110}		
		12 ^{±0,135}		
		15 ^{±0,135}		
		16 ^{±0,135}		
		18 ^{±0,135}		
		20 ^{±0,165}		
		23 ^{±0,165}		
		25 ^{±0,165}		
		30 ^{±0,165}		
10	17	12 ^{±0,135}	0,4	
		15 ^{±0,135}		
		16 ^{±0,135}		
		17 ^{±0,135}		
		20 ^{±0,165}		
	18	8 ^{±0,110}	0,4	
		10 ^{±0,110}		
		12 ^{±0,135}		
		15 ^{±0,135}		
		16 ^{±0,135}		
20	18 ^{±0,135}	0,6		
	20 ^{±0,165}			
	25 ^{±0,165}			
	30 ^{±0,165}			
	12 ^{±0,135}		0,4	
	15 ^{±0,135}			
16 ^{±0,135}				
12,1	18	10 ^{±0,110}	0,4	
		15 ^{±0,135}	0,2	
13	16	10 ^{±0,135}	0,3	
		15 ^{±0,135}	0,2	
14	18	10 ^{±0,110}	0,3	
		12 ^{±0,135}		

Dimensioni (mm) Dimensions (mm)				
d _(G7)	D _(s7)	L _(js13)	C _{max}	
10	18	13 ^{±0,135}	0,3	
		14 ^{±0,135}		
		15 ^{±0,135}		
		18 ^{±0,135}		
		20 ^{±0,165}		
		22 ^{±0,165}		
		25 ^{±0,165}		
		26 ^{±0,165}		
		28 ^{±0,165}		
		30 ^{±0,165}		
14	14	10 ^{±0,110}	0,4	
		12 ^{±0,135}		
		14 ^{±0,135}		
		15 ^{±0,135}		
		16 ^{±0,135}		
		18 ^{±0,135}		
		20 ^{±0,165}		
		22 ^{±0,165}		
		25 ^{±0,165}		
		28 ^{±0,165}		
10	22	15 ^{±0,135}	0,6	
		20 ^{±0,165}		
		25 ^{±0,165}		
		30 ^{±0,165}		
		12 ^{±0,135}		0,3
	15 ^{±0,135}			
	17 ^{±0,135}			
	19 ^{±0,135}			
	20 ^{±0,165}			
	18	25 ^{±0,165}	0,3	
27 ^{±0,165}				
30 ^{±0,165}				
35 ^{±0,195}				
10 ^{±0,110}		0,3		
15 ^{±0,135}				
16 ^{±0,135}				
20 ^{±0,165}				
25 ^{±0,165}				
15	19	30 ^{±0,165}	0,3	
		32 ^{±0,195}		
		10 ^{±0,110}		0,4
		12 ^{±0,135}		
		15 ^{±0,135}		
	16 ^{±0,135}			
	20	20 ^{±0,165}	0,4	
		24 ^{±0,165}		
		25 ^{±0,165}		
		28 ^{±0,165}		
30 ^{±0,165}				
10	20	40 ^{±0,195}	0,4	

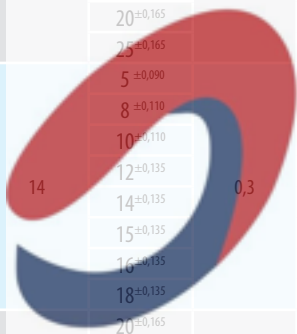

mayoral
Suministros industriales y Servicios

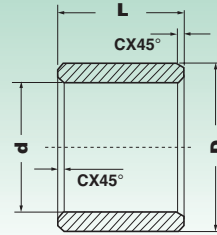

Dimensioni (mm) Dimensions (mm)			
d _(G7)	D _(s7)	L _(js13)	C _{max}
15	21	15 ^{±0,135}	0,4
		16 ^{±0,135}	
		20 ^{±0,165}	
		21 ^{±0,165}	
		25 ^{±0,165}	
		30 ^{±0,165}	
		32 ^{±0,195}	
	22	15 ^{±0,135}	0,6
		16 ^{±0,135}	
		20 ^{±0,165}	
		22 ^{±0,165}	
		25 ^{±0,165}	
		30 ^{±0,165}	
		40 ^{±0,195}	
		30 ^{±0,165}	
24	30 ^{±0,165}	0,7	
	25 ^{±0,135}	0,7	
16	18	10 ^{±0,110}	0,2
		12 ^{±0,135}	
		20 ^{±0,165}	
		22 ^{±0,165}	
		30 ^{±0,165}	
	19	5,5 ^{±0,090}	0,3
		12 ^{±0,135}	
		14,2 ^{±0,135}	
		16 ^{±0,135}	
		18 ^{±0,135}	
	20	19 ^{±0,135}	0,3
		20 ^{±0,165}	
		22 ^{±0,165}	
		25 ^{±0,165}	
		8 ^{±0,110}	
12 ^{±0,135}			
15 ^{±0,135}			
16 ^{±0,135}			
18 ^{±0,135}			
20 ^{±0,165}			
22	20	25 ^{±0,165}	0,3
		28 ^{±0,165}	
		30 ^{±0,165}	
		32 ^{±0,195}	
		32 ^{±0,195}	
	22	10 ^{±0,110}	0,4
		12 ^{±0,135}	
		15 ^{±0,135}	
		16 ^{±0,135}	
		20 ^{±0,165}	
		22 ^{±0,165}	
		25 ^{±0,165}	
		30 ^{±0,165}	
		32 ^{±0,195}	
		35 ^{±0,195}	
24	20 ^{±0,165}	0,6	

Dimensioni (mm) Dimensions (mm)			
d _(G7)	D _(s7)	L _(js13)	C _{max}
17	21	22 ^{±0,165}	0,3
		32 ^{±0,195}	
	22	12 ^{±0,135}	0,4
		13 ^{±0,135}	
		15 ^{±0,135}	
		17 ^{±0,135}	
		20 ^{±0,165}	
		22 ^{±0,165}	
		23 ^{±0,165}	
	23	25 ^{±0,165}	0,4
		30 ^{±0,165}	
		35 ^{±0,195}	
		17 ^{±0,135}	
		23 ^{±0,165}	
		17 ^{±0,135}	
20 ^{±0,165}			
25 ^{±0,165}			
18	22	22,5 ^{±0,165}	0,3
		25 ^{±0,165}	
		28 ^{±0,165}	
		30 ^{±0,165}	
		36 ^{±0,195}	
	23	40 ^{±0,195}	0,4
		18 ^{±0,135}	
		23 ^{±0,165}	
		24,7 ^{±0,165}	
		28 ^{±0,165}	
	24	16 ^{±0,135}	0,4
		18 ^{±0,135}	
		20 ^{±0,165}	
		22 ^{±0,165}	
		24 ^{±0,165}	
25 ^{±0,165}			
28 ^{±0,165}			
30 ^{±0,165}			
35 ^{±0,195}			
36 ^{±0,195}			
25	40 ^{±0,195}	0,6	
	16 ^{±0,135}		
	18 ^{±0,135}		
	20 ^{±0,165}		
	22 ^{±0,165}		
	25 ^{±0,165}		
	25 ^{±0,165}		
	28 ^{±0,165}		

Dimensioni (mm) Dimensions (mm)			
d _(G7)	D _(s7)	L _(js13)	C _{max}
18	25	30 ^{±0,165}	0,6
		36 ^{±0,195}	
		40 ^{±0,195}	
19	25	19 ^{±0,135}	0,4
		25 ^{±0,165}	
22	22	10 ^{±0,110}	0,2
		20 ^{±0,165}	
23	23	7 ^{±0,090}	0,3
		24 ^{±0,165}	
20	25	7 ^{±0,090}	0,3
		10 ^{±0,110}	
		12 ^{±0,135}	
		14 ^{±0,135}	
		16 ^{±0,135}	
		18 ^{±0,135}	
		20 ^{±0,165}	
		22 ^{±0,165}	
		24 ^{±0,165}	
		25 ^{±0,165}	
		27 ^{±0,165}	
		30 ^{±0,165}	
		32 ^{±0,195}	
		15 ^{±0,135}	
		26	
20 ^{±0,165}			
22 ^{±0,165}			
25 ^{±0,165}			
28 ^{±0,165}			
30 ^{±0,165}			
32 ^{±0,195}			
34 ^{±0,195}			
35 ^{±0,195}			
40 ^{±0,195}			
27	27	7 ^{±0,110}	0,4
		12 ^{±0,135}	
		15 ^{±0,135}	
		16 ^{±0,135}	
		20 ^{±0,165}	
		25 ^{±0,165}	
28	28	16 ^{±0,135}	0,6
		20 ^{±0,165}	
		25 ^{±0,165}	
		32 ^{±0,195}	

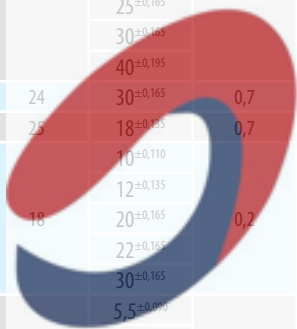

mayoral
Suministros Industriales y Servicios

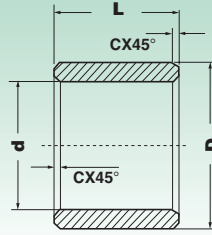

Dimensioni (mm) Dimensions (mm)				
d _(G7)	D _(s7)	L _(js13)	C _{max}	
20	28	20 ^{±0,165}	0,6	
		24 ^{±0,165}		
		25 ^{±0,165}		
		28 ^{±0,165}		
		30 ^{±0,165}		
		32 ^{±0,195}		
		35 ^{±0,195}		
		40 ^{±0,195}		
	30	12 ^{±0,135}	0,7	
		20 ^{±0,165}		
		25 ^{±0,165}		
		30 ^{±0,165}		
		35 ^{±0,195}		
		40 ^{±0,195}		
32	30 ^{±0,165}	0,8		
	24	19,5 ^{±0,135}	0,3	
21	26	20 ^{±0,165}	0,3	
		22 ^{±0,165}		
22	27	18 ^{±0,135}	0,4	
		20 ^{±0,165}		
		22 ^{±0,165}		
		25 ^{±0,165}		
		28 ^{±0,165}		
		30 ^{±0,165}		
		35 ^{±0,195}		
		36 ^{±0,195}		
		40 ^{±0,195}		
		15 ^{±0,135}		0,4
	18 ^{±0,135}			
	20 ^{±0,165}			
	22 ^{±0,165}			
	25 ^{±0,165}			
	28 ^{±0,165}			
	30 ^{±0,165}			
	34 ^{±0,195}			
	35 ^{±0,195}			
	36 ^{±0,195}			
	40 ^{±0,195}			
	29	30	18 ^{±0,135}	
			22 ^{±0,165}	
28 ^{±0,165}				
36 ^{±0,195}				
30	30	35 ^{±0,195}	0,6	
		40 ^{±0,195}		

Dimensioni (mm) Dimensions (mm)					
d _(G7)	D _(s7)	L _(js13)	C _{max}		
22	32	20 ^{±0,165}	0,7		
		22 ^{±0,165}			
		30 ^{±0,165}			
		32 ^{±0,195}			
		40 ^{±0,195}			
		45 ^{±0,195}			
		50 ^{±0,195}			
		28		16 ^{±0,135}	0,3
				18 ^{±0,135}	
		24		30	20 ^{±0,165}
24 ^{±0,165}					
25	31	20 ^{±0,165}	0,4		
		25 ^{±0,165}			
		30 ^{±0,165}			
		32 ^{±0,195}			
		40 ^{±0,195}			
	32	17 ^{±0,135}	0,6		
		20 ^{±0,165}			
		25 ^{±0,165}			
		30 ^{±0,165}			
		32 ^{±0,195}			
26	35	15 ^{±0,135}	0,7		
		20 ^{±0,165}			
		25 ^{±0,165}			
		30 ^{±0,165}			
		35 ^{±0,195}			
	36	16 ^{±0,135}	0,8		
		25 ^{±0,165}			
		30 ^{±0,165}			
		32 ^{±0,195}			
		50 ^{±0,195}			
28	33	40 ^{±0,195}	0,3		
		45 ^{±0,195}			
32	35	30 ^{±0,165}	0,3		
		40 ^{±0,195}			
28	33	20 ^{±0,165}	0,4		
		22 ^{±0,165}			
		28 ^{±0,165}			
		40 ^{±0,195}			

Dimensioni (mm) Dimensions (mm)			
d _(G7)	D _(s7)	L _(js13)	C _{max}
28	33	30 ^{±0,165}	0,4
		33 ^{±0,195}	
		36 ^{±0,195}	
		40 ^{±0,195}	
		45 ^{±0,195}	
	35	15 ^{±0,135}	0,6
		25 ^{±0,165}	
		28 ^{±0,165}	
		30 ^{±0,165}	
		35 ^{±0,195}	
30	36	20 ^{±0,165}	0,6
		22 ^{±0,165}	
		25 ^{±0,165}	
		28 ^{±0,165}	
		30 ^{±0,165}	
	33	35 ^{±0,195}	0,3
		45 ^{±0,195}	
		25 ^{±0,165}	
		45 ^{±0,195}	
		50 ^{±0,195}	
30	34	20 ^{±0,165}	0,3
		40 ^{±0,195}	
	35	10 ^{±0,110}	0,4
		15 ^{±0,135}	
		20 ^{±0,165}	
		25 ^{±0,165}	
		30 ^{±0,165}	
		35 ^{±0,195}	
		40 ^{±0,195}	
		45 ^{±0,195}	
50 ^{±0,195}			
38	36	10 ^{±0,110}	0,4
		30 ^{±0,165}	
		35 ^{±0,195}	
		40 ^{±0,195}	
		45 ^{±0,195}	
	38	20 ^{±0,165}	0,6
		24 ^{±0,165}	
		25 ^{±0,165}	
		30 ^{±0,165}	
		35 ^{±0,195}	
38	38	20 ^{±0,165}	0,6
		24 ^{±0,165}	
		25 ^{±0,165}	
		30 ^{±0,165}	
		35 ^{±0,195}	
		40 ^{±0,195}	
38	38	38 ^{±0,195}	0,6
		40 ^{±0,195}	
		45 ^{±0,195}	
		50 ^{±0,195}	

mayoral
Suministros Industriales y Servicios

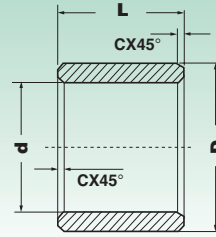

Dimensioni (mm) Dimensions (mm)				
d _(G7)	D _(s7)	L _(js13)	C _{max}	
30	40	10 ^{±0,110}	0,7	
		20 ^{±0,165}		
		25 ^{±0,165}		
		30 ^{±0,165}		
		35 ^{±0,195}		
		40 ^{±0,195}		
		45 ^{±0,195}		
		50 ^{±0,195}		
60 ^{±0,230}				
30,1	38	20 ^{±0,165}	0,6	
32	35	35 ^{±0,195}	0,3	
		40 ^{±0,195}		
	36	25 ^{±0,165}	0,3	
		30 ^{±0,165}		
	38	40	20 ^{±0,165}	0,4
			25 ^{±0,165}	
			30 ^{±0,165}	
			32 ^{±0,195}	
			38 ^{±0,195}	
			40 ^{±0,195}	
	40	40	20 ^{±0,165}	0,6
			25 ^{±0,165}	
30 ^{±0,165}				
32 ^{±0,195}				
32	40	32 ^{±0,195}	0,6	
		35 ^{±0,195}		
		40 ^{±0,195}		
		45 ^{±0,195}		
		50 ^{±0,195}		
34	40	50 ^{±0,195}	0,4	
35	39	30 ^{±0,165}	0,3	
		20 ^{±0,165}		
	40	40	25 ^{±0,165}	0,4
			30 ^{±0,165}	
			35 ^{±0,195}	
			40 ^{±0,195}	
			45 ^{±0,195}	
	41	41	25 ^{±0,165}	0,4
			35 ^{±0,195}	
			40 ^{±0,195}	
	42	42	16 ^{±0,135}	0,6
			35 ^{±0,195}	
			42 ^{±0,195}	
			50 ^{±0,195}	
	44	44	22 ^{±0,165}	0,7
			28 ^{±0,165}	
	45	45	35 ^{±0,195}	0,7
			20 ^{±0,165}	
25 ^{±0,165}				
30 ^{±0,165}				

Dimensioni (mm) Dimensions (mm)					
d _(G7)	D _(s7)	L _(js13)	C _{max}		
35	45	35 ^{±0,195}	0,7		
		40 ^{±0,195}			
		45 ^{±0,195}			
		50 ^{±0,195}			
		55 ^{±0,230}			
		60 ^{±0,230}			
		50		50 ^{±0,195}	0,7
		42		22 ^{±0,165}	0,4
28 ^{±0,165}					
36	42	26 ^{±0,195}	0,4		
		45 ^{±0,195}			
	45	45	50 ^{±0,195}	0,7	
			22 ^{±0,165}		
	44	44	28 ^{±0,165}	0,4	
			36 ^{±0,195}		
			45 ^{±0,195}		
			50 ^{±0,195}		
	48	48	25 ^{±0,165}	0,7	
			35 ^{±0,195}		
			45 ^{±0,195}		
			55 ^{±0,230}		
20 ^{±0,165}					
30 ^{±0,165}					
40	45	30 ^{±0,165}	0,4		
		35 ^{±0,195}			
		40 ^{±0,195}			
		45 ^{±0,195}			
		50 ^{±0,195}			
	46	46	25 ^{±0,165}	0,4	
			30 ^{±0,165}		
			32 ^{±0,195}		
	50	50	40 ^{±0,195}	0,7	
			50 ^{±0,195}		
			20 ^{±0,165}		
			25 ^{±0,165}		
30 ^{±0,165}					
60	60	25 ^{±0,165}	0,8		
		30 ^{±0,165}			
		32 ^{±0,165}			
42	48	40 ^{±0,195}	0,4		
		50 ^{±0,195}			
		40 ^{±0,195}		0,7	
		50 ^{±0,195}			
43	55	40 ^{±0,195}	0,8		

Dimensioni (mm) Dimensions (mm)					
d _(G7)	D _(s7)	L _(js13)	C _{max}		
45	51	28 ^{±0,165}	0,4		
		35 ^{±0,195}			
		36 ^{±0,195}			
		45 ^{±0,195}			
		55 ^{±0,230}			
		56 ^{±0,230}			
		55		30 ^{±0,165}	0,7
		35 ^{±0,195}			
45 ^{±0,195}					
48	55	50 ^{±0,195}	0,7		
		55 ^{±0,230}			
	56	56	60 ^{±0,230}	0,8	
			65 ^{±0,230}		
	60	60	28 ^{±0,165}	0,8	
			35 ^{±0,195}		
			45 ^{±0,195}		
			56 ^{±0,230}		
	55	55	40 ^{±0,195}	0,8	
			45 ^{±0,195}		
			60 ^{±0,230}		
			50 ^{±0,195}		
55 ^{±0,230}					
60 ^{±0,230}					
50	58	50 ^{±0,195}	0,7		
		54		45 ^{±0,195}	0,3
	56	56	32 ^{±0,195}	0,4	
			40 ^{±0,195}		
			50 ^{±0,195}		
			63 ^{±0,230}		
55	60	30 ^{±0,165}	0,7		
		32 ^{±0,165}			
		35 ^{±0,195}			
		40 ^{±0,195}			
		45 ^{±0,195}			
	63	63	50 ^{±0,195}	0,6	
			55 ^{±0,230}		
			40 ^{±0,195}		0,7
	65	65	55 ^{±0,230}		
			60 ^{±0,230}		
70	70	65 ^{±0,230}	0,8		
		70 ^{±0,230}			
		75 ^{±0,230}			

mayora
Suministros Industriales y Servicios

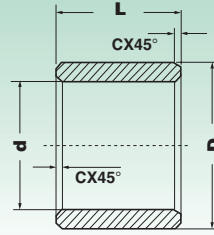

Dimensioni (mm) Dimensions (mm)			
$d_{(G7)}$	$D_{(s7)}$	$L_{(js13)}$	C_{max}
60	68	50 $\pm 0,195$	0,6
		60 $\pm 0,230$	
	70	25 $\pm 0,165$	0,7
		50 $\pm 0,195$	
		60 $\pm 0,230$	
		70 $\pm 0,230$	
		80 $\pm 0,230$	
		90 $\pm 0,270$	
	72	120 $\pm 0,270$	0,8
		50 $\pm 0,195$	
		60 $\pm 0,230$	
		70 $\pm 0,230$	
	75	60 $\pm 0,230$	0,8
		70 $\pm 0,230$	
75 $\pm 0,230$			
80 $\pm 0,230$			
90 $\pm 0,270$			
120 $\pm 0,270$			
63	70	40 $\pm 0,195$	0,6
		50 $\pm 0,195$	
65	75	65 $\pm 0,230$	0,7
		70 $\pm 0,230$	

Dimensioni (mm) Dimensions (mm)			
$d_{(G7)}$	$D_{(s7)}$	$L_{(js13)}$	C_{max}
65	75	80 $\pm 0,230$	0,7
		40 $\pm 0,195$	
65	80	60 $\pm 0,230$	0,8
		80 $\pm 0,230$	
		90 $\pm 0,270$	
		28 $\pm 0,165$	
65	80	35 $\pm 0,195$	0,7
		60 $\pm 0,230$	
		70 $\pm 0,230$	
		80 $\pm 0,230$	
		90 $\pm 0,270$	
		120 $\pm 0,270$	
70	85	60 $\pm 0,230$	0,8
		70 $\pm 0,230$	
		80 $\pm 0,230$	
		90 $\pm 0,270$	
75	90	60 $\pm 0,230$	0,8
		70 $\pm 0,230$	
		80 $\pm 0,230$	
		90 $\pm 0,270$	
75	90	35 $\pm 0,195$	0,7
		70 $\pm 0,230$	
		80 $\pm 0,230$	
		100 $\pm 0,270$	
80	95	70 $\pm 0,230$	0,8
		80 $\pm 0,230$	
80	95	90 $\pm 0,270$	0,8
		100 $\pm 0,270$	

Dimensioni (mm) Dimensions (mm)			
$d_{(G7)}$	$D_{(s7)}$	$L_{(js13)}$	C_{max}
80	96	60 $\pm 0,230$	0,8
		80 $\pm 0,230$	
80	100	120 $\pm 0,270$	0,8
		60 $\pm 0,230$	
		70 $\pm 0,230$	
85	100	80 $\pm 0,230$	0,8
		100 $\pm 0,270$	
		70 $\pm 0,230$	
85	100	80 $\pm 0,230$	0,7
		90 $\pm 0,270$	
		100 $\pm 0,270$	
		120 $\pm 0,270$	
90	110	65 $\pm 0,230$	0,8
		80 $\pm 0,230$	
		110 $\pm 0,270$	
90	110	65 $\pm 0,230$	0,7
		80 $\pm 0,230$	
		120 $\pm 0,270$	
100	120	65 $\pm 0,230$	0,8
		80 $\pm 0,230$	
		100 $\pm 0,270$	
100	120,3	120 $\pm 0,270$	0,8
		65 $\pm 0,230$	
		120 $\pm 0,270$	
110	120,3	65 $\pm 0,230$	0,8
		100 $\pm 0,270$	
110	150	100 $\pm 0,270$	0,8
		120 $\pm 0,270$	
-	-	-	-

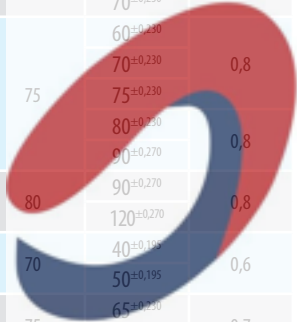

mayoral
Suministros Industriales y Servicios

Per ordinare specificare: BNZ e/o FE + d + L

To order, please specify: BNZ e/o FE + d + L

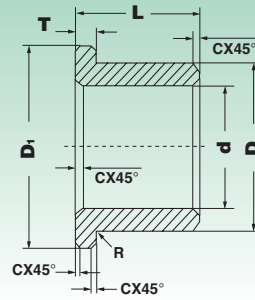

Dimensioni (mm) Dimensions (mm)						
d _(G7)	D _(s7)	D _{1(j513)}	T _(j513)	L _(j513)	R	C _{max}
2	5	8	1,5	3 ^{±0,070}	0,3	0,3
3	6	9	1,5	8	0,3	0,3
				10 ^{±0,110}		
				4 ^{±0,090}		
				5 ^{±0,090}		
				6 ^{±0,090}		
4	8	10	2	6 ^{±0,090}	0,3	0,3
				8 ^{±0,110}		
				3 ^{±0,070}		
				4 ^{±0,090}		
				5 ^{±0,090}		
5	9	12	2	6 ^{±0,090}	0,3	0,3
				8 ^{±0,110}		
				10 ^{±0,110}		
				12 ^{±0,135}		
				14 ^{±0,165}		
6	10	13	2	4 ^{±0,090}	0,3	0,3
				5 ^{±0,090}		
				8 ^{±0,110}		
				7 ^{±0,110}		
				8 ^{±0,110}		
7	11	15	2	12 ^{±0,135}	0,3	0,3
				15 ^{±0,135}		
				16 ^{±0,135}		
				15 ^{±0,135}		
				8 ^{±0,110}		
				10 ^{±0,110}		
				12 ^{±0,135}		
				14 ^{±0,135}		
				16 ^{±0,135}		
				6 ^{±0,090}		
				8 ^{±0,110}		
				10 ^{±0,110}		
				12 ^{±0,135}		
				13 ^{±0,135}		
				16 ^{±0,135}		
20 ^{±0,165}						
8	12	16	2	6 ^{±0,090}	0,3	0,3
				8 ^{±0,110}		
				10 ^{±0,110}		
				12 ^{±0,135}		
				14 ^{±0,135}		
9	13	18	3	6 ^{±0,090}	0,6	0,4
				8 ^{±0,110}		
				10 ^{±0,110}		
				12 ^{±0,135}		
				14 ^{±0,135}		
10	14	20	4,5	6 ^{±0,090}	0,6	0,4
				8 ^{±0,110}		
				10 ^{±0,110}		
				12 ^{±0,135}		
				14 ^{±0,135}		
11	15	22	6	6 ^{±0,090}	0,6	0,4
				8 ^{±0,110}		
				10 ^{±0,110}		
				12 ^{±0,135}		
				14 ^{±0,135}		

Dimensioni (mm) Dimensions (mm)						
d _(G7)	D _(s7)	D _{1(j513)}	T _(j513)	L _(j513)	R	C _{max}
7	12	15	2,5	15 ^{±0,135}	0,3	0,4
		16	2	8 ^{±0,110} 12 ^{±0,135}	0,3	0,4
8	12	16	2	6 ^{±0,090}	0,3	0,3
				6 ^{±0,090}		
				8 ^{±0,110}		
				10 ^{±0,110}		
				12 ^{±0,135}		
9	13	20	2	14 ^{±0,135}	0,3	0,3
				15 ^{±0,135}		
				10 ^{±0,110}		
				8 ^{±0,110}		
				11 ^{±0,135}		
10	14	18	3	12 ^{±0,135}	0,6	0,4
				14 ^{±0,135}		
				20 ^{±0,165}		
				6 ^{±0,090}		
				8 ^{±0,110}		
11	15	20	2	20 ^{±0,165}	0,6	0,6
				6 ^{±0,090}		
				10 ^{±0,110}		
				12 ^{±0,135}		
				14 ^{±0,135}		
12	16	22	4,5	10 ^{±0,110}	0,6	0,4
				12 ^{±0,135}		
				14 ^{±0,135}		
				16 ^{±0,135}		
				20 ^{±0,165}		
13	17	24	6	10 ^{±0,110}	0,6	0,4
				12 ^{±0,135}		
				14 ^{±0,135}		
				16 ^{±0,135}		
				20 ^{±0,165}		
14	18	26	8	10 ^{±0,110}	0,6	0,4
				12 ^{±0,135}		
				14 ^{±0,135}		
				16 ^{±0,135}		
				20 ^{±0,165}		
15	19	28	10	10 ^{±0,110}	0,6	0,4
				12 ^{±0,135}		
				14 ^{±0,135}		
				16 ^{±0,135}		
				20 ^{±0,165}		
16	20	30	12	10 ^{±0,110}	0,6	0,4
				12 ^{±0,135}		
				14 ^{±0,135}		
				16 ^{±0,135}		
				20 ^{±0,165}		
17	21	32	14	10 ^{±0,110}	0,6	0,4
				12 ^{±0,135}		
				14 ^{±0,135}		
				16 ^{±0,135}		
				20 ^{±0,165}		
18	22	34	16	10 ^{±0,110}	0,6	0,4
				12 ^{±0,135}		
				14 ^{±0,135}		
				16 ^{±0,135}		
				20 ^{±0,165}		
19	23	36	18	10 ^{±0,110}	0,6	0,4
				12 ^{±0,135}		
				14 ^{±0,135}		
				16 ^{±0,135}		
				20 ^{±0,165}		
20	24	38	20	10 ^{±0,110}	0,6	0,4
				12 ^{±0,135}		
				14 ^{±0,135}		
				16 ^{±0,135}		
				20 ^{±0,165}		
21	25	40	22	10 ^{±0,110}	0,6	0,4
				12 ^{±0,135}		
				14 ^{±0,135}		
				16 ^{±0,135}		
				20 ^{±0,165}		
22	26	42	24	10 ^{±0,110}	0,6	0,4
				12 ^{±0,135}		
				14 ^{±0,135}		
				16 ^{±0,135}		
				20 ^{±0,165}		
23	27	44	26	10 ^{±0,110}	0,6	0,4
				12 ^{±0,135}		
				14 ^{±0,135}		
				16 ^{±0,135}		
				20 ^{±0,165}		
24	28	46	28	10 ^{±0,110}	0,6	0,4
				12 ^{±0,135}		
				14 ^{±0,135}		
				16 ^{±0,135}		
				20 ^{±0,165}		
25	29	48	30	10 ^{±0,110}	0,6	0,4
				12 ^{±0,135}		
				14 ^{±0,135}		
				16 ^{±0,135}		
				20 ^{±0,165}		
26	30	50	32	10 ^{±0,110}	0,6	0,4
				12 ^{±0,135}		
				14 ^{±0,135}		
				16 ^{±0,135}		
				20 ^{±0,165}		
27	31	52	34	10 ^{±0,110}	0,6	0,4
				12 ^{±0,135}		
				14 ^{±0,135}		
				16 ^{±0,135}		
				20 ^{±0,165}		
28	32	54	36	10 ^{±0,110}	0,6	0,4
				12 ^{±0,135}		
				14 ^{±0,135}		
				16 ^{±0,135}		
				20 ^{±0,165}		
29	33	56	38	10 ^{±0,110}	0,6	0,4
				12 ^{±0,135}		
				14 ^{±0,135}		
				16 ^{±0,135}		
				20 ^{±0,165}		
30	34	58	40	10 ^{±0,110}	0,6	0,4
				12 ^{±0,135}		
				14 ^{±0,135}		
				16 ^{±0,135}		
				20 ^{±0,165}		

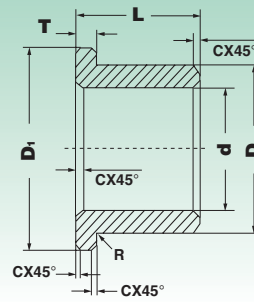

Dimensioni (mm) Dimensions (mm)						
d _(G7)	D _(s7)	D _{1(jS13)}	T _(jS13)	L _(jS13)	R	C _{max}
10	16	20	3	8 ^{±0,110}	0,6	0,4
				10 ^{±0,110}		
				16 ^{±0,135}		
				20 ^{±0,165}		
				30 ^{±0,165}		
		22	8 ^{±0,110}			
			10 ^{±0,110}			
			16 ^{±0,135}			
			18 ^{±0,135}			
			20 ^{±0,165}			
12	14	20	2	18 ^{±0,135}	0,6	0,2
				9 ^{±0,110}		
	15	18	1,5	20 ^{±0,165}	0,6	0,3
				7 ^{±0,110}		
		21	3	12 ^{±0,135}		
				16 ^{±0,135}		
	16	18	2	12 ^{±0,135}	0,6	0,4
				14 ^{±0,135}		
				20 ^{±0,165}		
				8 ^{±0,110}		
		20	2	10 ^{±0,110}		
				11 ^{±0,110}		
				12 ^{±0,135}		
				16 ^{±0,135}		
	17	23	3	12 ^{±0,135}	0,6	0,4
				16 ^{±0,135}		
				20 ^{±0,165}		
				25 ^{±0,165}		
				10 ^{±0,110}		
		18	22	3	12 ^{±0,135}	
16 ^{±0,135}						
18 ^{±0,135}						
20 ^{±0,165}						
25 ^{±0,165}						
24	4	3	8 ^{±0,110}			
			12 ^{±0,135}			
			20 ^{±0,165}			
			25 ^{±0,165}			
13	16	20	2	15 ^{±0,135}	0,6	0,4
	18	23	5	25 ^{±0,165}	0,6	0,4
14	18	22	2	14 ^{±0,135}	0,6	0,3
				18 ^{±0,135}		
				22 ^{±0,165}		
				25 ^{±0,165}		
				10 ^{±0,110}		
	20	25	3	12 ^{±0,135}		
				14 ^{±0,135}		
				20 ^{±0,165}		
				25 ^{±0,165}		
				30 ^{±0,165}		

Dimensioni (mm) Dimensions (mm)												
d _(G7)	D _(s7)	D _{1(jS13)}	T _(jS13)	L _(jS13)	R	C _{max}						
14	20	26	3	10 ^{±0,110}	0,6	0,4						
				14 ^{±0,135}								
				15 ^{±0,135}								
				18 ^{±0,135}								
				20 ^{±0,165}								
				22 ^{±0,165}								
				28 ^{±0,165}								
				16 ^{±0,135}								
				20 ^{±0,165}								
				25 ^{±0,165}								
15	19	25	3	16 ^{±0,135}	0,6	0,3						
				20 ^{±0,165}								
				25 ^{±0,165}								
				24			2,5	30 ^{±0,165}				
				20			25	3	15 ^{±0,135}	0,6	0,4	
									12 ^{±0,135}			
				16			21	27	3	25 ^{±0,165}	0,6	0,4
										30 ^{±0,165}		
										20 ^{±0,165}		
										32 ^{±0,195}		
10 ^{±0,110}												
15 ^{±0,135}												
16 ^{±0,135}												
20 ^{±0,165}												
25 ^{±0,165}												
32 ^{±0,195}												
16	22	28	3	12 ^{±0,135}	0,6	0,6						
				15 ^{±0,135}								
				16 ^{±0,135}								
				22 ^{±0,165}								
				25 ^{±0,165}								
				30 ^{±0,165}								
				9 ^{±0,110}								
				16 ^{±0,135}								
				20 ^{±0,165}								
				25 ^{±0,165}								
16	22	28	3	12 ^{±0,135}	0,6	0,4						
				16 ^{±0,135}								
				21 ^{±0,165}								
				21 ^{±0,165}								
				15 ^{±0,135}								
				16 ^{±0,135}								
				3,5			16 ^{±0,135}					
				4			20 ^{±0,165}					
				3			22 ^{±0,165}					
				4			25 ^{±0,165}					
3,5	30 ^{±0,165}											



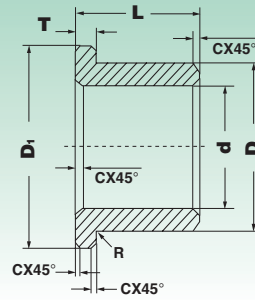

Dimensioni (mm) Dimensions (mm)									
d _(G7)	D _(s7)	D _{1(j513)}	T _(j513)	L _(j513)	R	C _{max}			
16	22	28	3,5	30 ^{±0,165}	0,6	0,4			
			3	32 ^{±0,195}					
			3,5	35 ^{±0,195}					
17	22	26	2	30 ^{±0,165}	0,6	0,4			
	25	32	4	17 ^{±0,135}	0,6	0,6			
				25 ^{±0,165}					
18	22	26	2	18 ^{±0,135}	0,6	0,3			
				22 ^{±0,165}					
				28 ^{±0,165}					
	24	28	30	3	12 ^{±0,135}	0,6	0,4		
					15 ^{±0,135}				
					18 ^{±0,135}				
		30	31	5	5	22 ^{±0,165}	0,6	0,4	
						28 ^{±0,165}			
						30 ^{±0,165}			
			32	32	4	4	14 ^{±0,135}	0,6	0,6
							16 ^{±0,135}		
							18 ^{±0,135}		
20	24	28	2	25 ^{±0,165}	0,6	0,3			
				16 ^{±0,135}					
				20 ^{±0,165}					
	25	30	3	3	25 ^{±0,165}	0,6	0,4		
					30 ^{±0,165}				
					25 ^{±0,165}				
	26	32	32	3	12 ^{±0,135}	0,6	0,4		
					15 ^{±0,135}				
					16 ^{±0,135}				
					20 ^{±0,165}				
					23 ^{±0,165}				
					25 ^{±0,165}				
28		35	4	4	30 ^{±0,165}	0,6	0,6		
					35 ^{±0,195}				
					40 ^{±0,195}				
		30	35	4	4	16 ^{±0,135}	0,6	0,6	
						20 ^{±0,165}			
						25 ^{±0,165}			
22	27	32	2,5	18 ^{±0,135}	0,6	0,4			
				22 ^{±0,165}					
				28 ^{±0,165}					

Dimensioni (mm) Dimensions (mm)								
d _(G7)	D _(s7)	D _{1(j513)}	T _(j513)	L _(j513)	R	C _{max}		
16	22	28	3	32	0,6	0,4		
				20 ^{±0,165}				
				15 ^{±0,135}				
				20 ^{±0,165}				
				25 ^{±0,165}				
				30 ^{±0,165}				
17	25	32	4	35	0,6	0,6		
				22 ^{±0,165}				
				18 ^{±0,135}				
	29	36	3,5	3,5	22 ^{±0,165}	0,6	0,6	
					28 ^{±0,165}			
					40 ^{±0,195}			
18	24	30	3	12 ^{±0,135}	0,6	0,4		
				15 ^{±0,135}				
				18 ^{±0,135}				
				22 ^{±0,165}				
				28 ^{±0,165}				
				30 ^{±0,165}				
	32	32	40	5	20 ^{±0,165}	0,8	0,7	
					22 ^{±0,165}			
					30 ^{±0,165}			
		35	35	40	4,6	32 ^{±0,195}	0,6	0,6
						40 ^{±0,195}		
						45 ^{±0,195}		
20	25	32	4	20 ^{±0,165}	0,6	0,4		
				25 ^{±0,165}				
				30 ^{±0,165}				
				32 ^{±0,195}				
				16 ^{±0,135}				
				20 ^{±0,165}				
	32	40	40	5	25 ^{±0,165}	0,8	0,6	
					30 ^{±0,165}			
					32 ^{±0,195}			
		40	40	40	4	40 ^{±0,195}	0,8	0,6
						53 ^{±0,230}		
						16 ^{±0,135}		
25	32	40	5	16 ^{±0,135}	0,8	0,6		
				20 ^{±0,165}				
				25 ^{±0,165}				
				30 ^{±0,165}				
				32 ^{±0,195}				
				40 ^{±0,195}				
	35	45	45	5	53 ^{±0,230}	0,8	0,7	
					16 ^{±0,135}			
					25 ^{±0,165}			
		45	45	45	5	39 ^{±0,195}	0,8	0,7
						35 ^{±0,195}		
						45 ^{±0,195}		
28	33	38	2,5	22 ^{±0,165}	0,8	0,4		
				28 ^{±0,165}				
				35 ^{±0,195}				
	35	38	38	2,5	20 ^{±0,165}	0,8	0,6	
					28 ^{±0,165}			
					28 ^{±0,165}			

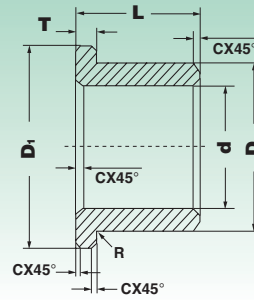

Dimensioni (mm) Dimensions (mm)						
d _(G7)	D _(s7)	D _{1(j513)}	T _(j513)	L _(j513)	R	C _{max}
28	36	44	4	20 ^{±0,165}	0,8	0,6
				22 ^{±0,165}		
				25 ^{±0,165}		
				28 ^{±0,165}		
				30 ^{±0,165}		
				35 ^{±0,195}		
				36 ^{±0,195}		
				40 ^{±0,195}		
40	50	5	16 ^{±0,135}	0,8	0,8	
34	45	2	20 ^{±0,165}	0,8	0,3	
30	35	40	3	30 ^{±0,165}	0,8	0,4
				35 ^{±0,195}		
				40 ^{±0,195}		
	38	46	4	20 ^{±0,165}	0,8	0,6
				25 ^{±0,165}		
				30 ^{±0,165}		
	50	45	5	35 ^{±0,195}	0,8	0,6
				45 ^{±0,195}		
				36 ^{±0,195}		
	45	45	5	25 ^{±0,165}	0,8	0,6
				30 ^{±0,165}		
				35 ^{±0,195}		
48	48	4	30 ^{±0,165}	0,8	0,6	
			35 ^{±0,195}			
			40 ^{±0,195}			
40	50	5	40 ^{±0,195}	0,8	0,7	
			42 ^{±0,195}			
			55 ^{±0,230}			
32	38	46	4	20 ^{±0,165}	0,8	0,4
				25 ^{±0,165}		
				32 ^{±0,195}		
	45	45	5	50 ^{±0,195}	0,8	0,6
				20 ^{±0,165}		
				25 ^{±0,165}		
	28	48	4	28 ^{±0,165}	0,8	0,6
				30 ^{±0,165}		
				32 ^{±0,195}		
	35	48	4	35 ^{±0,195}	0,8	0,6
36 ^{±0,195}						
40 ^{±0,195}						
42	48	5	15 ^{±0,135}	0,8	0,7	
			32 ^{±0,195}			
			40 ^{±0,195}			
35	45	55	5	20 ^{±0,165}	0,8	0,7
				25 ^{±0,165}		
				30 ^{±0,165}		
				35 ^{±0,195}		
				40 ^{±0,195}		
				50 ^{±0,195}		
36	45	48	4,5	22 ^{±0,165}	0,8	0,7
38	48	58	5	25 ^{±0,165}	0,8	0,7
				35 ^{±0,195}	0,8	0,7

Dimensioni (mm) Dimensions (mm)							
d _(G7)	D _(s7)	D _{1(j513)}	T _(j513)	L _(j513)	R	C _{max}	
39,5	48	55	5	15 ^{±0,135}	0,8	0,7	
40	46	56	5	50	0,8	0,4	
				60			
				50			
				60			
	42	52	62	5	50	0,8	0,7
					60		
					50		
					60		
45	55	65	6	40 ^{±0,195}	0,8	0,7	
				50 ^{±0,195}			
				60 ^{±0,230}			
	56	67	5,5	30 ^{±0,165}	0,8	0,8	
				35 ^{±0,195}			
				40 ^{±0,195}			
	56	62	3	45 ^{±0,195}	0,8	0,4	
				55 ^{±0,230}			
				65 ^{±0,230}			
	50	60	70	5	28 ^{±0,165}	0,8	0,7
36 ^{±0,165}							
45 ^{±0,195}							
60		70	6	32 ^{±0,195}	0,8	0,7	
				40 ^{±0,195}			
				50 ^{±0,195}			
55	64	71	5	30 ^{±0,195}	0,8	0,7	
				31 ^{±0,195}			
				40 ^{±0,195}			
				50 ^{±0,195}			

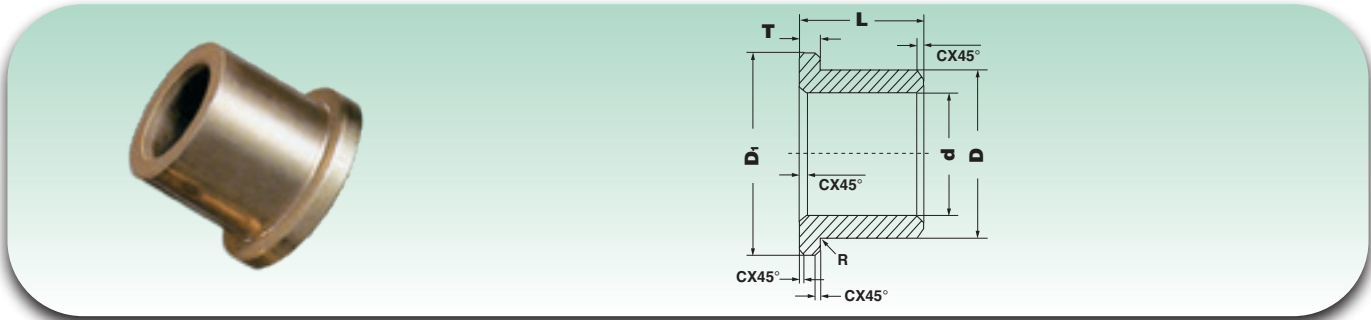

Dimensioni (mm) Dimensions (mm)							
d _(G7)	D _(s7)	D _{1(j513)}	T _(j513)	L _(j513)	R	C _{max}	
60	70	80	5	50 ^{-0.195}	0,8	0,7	
				60 ^{±0.230}			
	75	85	85	6	60 ^{±0.230}	0,8	0,8
					60 ^{±0.230}		
					65 ^{±0.230}		
					70 ^{±0.230}		
70	85	95	6	56 ^{±0.230}	0,8	0,8	
				60 ^{±0.230}			

Dimensioni (mm) Dimensions (mm)						
d _(G7)	D _(s7)	D _{1(j513)}	T _(j513)	L _(j513)	R	C _{max}
70	85	95	6	65 ^{±0.230}	0,8	0,8
				70 ^{±0.230}		
				80 ^{±0.230}		
80	95	105	8	60 ^{±0.230}	0,8	0,8
				70 ^{±0.230}		
				80 ^{±0.230}		
				90 ^{±0.230}		
100	110	115	5	95 ^{±0.230}	0,8	0,8

Per ordinare specificare: BNZF e/o FEF + d + D + D₁ + T + L To order, please specify: BNZF e/o FEF + d + D + D₁ + T + L





4. Caratteristiche boccole in bronzo 090 e 092

Le 090 e 092 sono boccole in bronzo fosforoso particolarmente indicate per la realizzazione di accoppiamenti con acciai da costruzione.

Queste tipologie di boccole, sia cilindriche, sia flangiate, sono ricavate da nastri in bronzo aventi spessori che vanno da 1 a 2,5 mm. Tra le principali caratteristiche che contraddistinguono queste boccole, troviamo:

- buona capacità di scorrimento
- buona resistenza agli agenti chimici
- capacità di carico elevate
- elevata conduttività termica
- facilità di montaggio nelle diverse applicazioni
- facilità nella lubrificazione
- ingombri ridotti
- intervalli di lubrificazione più lunghi
- resistenza agli urti ed alle oscillazioni

La loro superficie interna, può essere fornita con tasche sferiche (a calotta) o con tasche a forma di rombo (a losanga). Queste boccole trovano largo impiego in svariati settori, come ad esempio: macchine e ponti per sollevamento, macchine utensili, automobili, trattori e camion. Sono presenti anche una serie di boccole interamente in bronzo, derivanti dalla serie 090, con la differenza però che le tasche a calotta ed a losanga, presenti sulla superficie di strisciamento, sono sostituite da fori passanti (tipo 092), aventi maggior capacità di lubrificazione ed un'elevata resistenza agli agenti chimici. Per tutte le altre caratteristiche, tipiche delle boccole della serie 090 e 092 ed anche per le dimensioni, si rimanda alle tabelle in seguito riportate.

4. 090 e 092 bronze bushings characteristics

090 and 092 are bushings in phosphorous bronze which is particularly indicated to achieve coupling with construction steels.

These types of bushings, either cylindrical or flanged, are cut out of bronze sheets that are from 1 to 2,5mm thick. Among the principal characteristics that distinguish these bushings we find:

- good capacity to slide
- good resistance to chemical agents
- high load capacity
- high thermal conductivity
- each mounting in diverse applications
- easy to lubricate
- reduced obstruction
- longer ranges lubrication
- resistance to bumping and to oscillations

Their internal surface, can be supplied with spherical pockets (spherical cap pockets) or with a diamond shape (lozenge cap pockets).

These bushings are widely used in the machinery sector and bridges for lifting, tooling machines, automobiles, tractors and trucks.

There is also a series of bushings entirely in bronze, deriving from the series 090, where pockets have been substitute by circular passthrough holes (092 series).

All of the other characteristics are the same for 090 and 092 series, including the dimensions.

See the following tables.

4.1 Caratteristiche tecniche

4.1 Technical features

Composizione	CuSn8P0,3	Composition	CuSn8P0,3
Carico statico massimo	150N/mm²	Max static load	150N/mm²
Carico dinamico massimo	60N/mm²	Max dynamic load	60N/mm²
Durezza	90 ~ 120 HB	Hardness	90 ~ 120 HB
Velocità limite	2,5 m/s	Limit speed	2,5 m/s
Temperatura di funzionamento	-40 °C ~ + 150 °C	Operating temperature	-40 °C ~ + 150 °C

4.2 Lubrificazione

Il buon funzionamento delle boccole, viene spesso determinato anche da una altrettanto buona lubrificazione, in quanto è possibile prevenire anticipatamente l'eventuale insorgere di deterioramenti sia sulla boccola, sia sui contropezzi utilizzati come piani di scorrimento. Qualora le boccole fossero esposte ad agenti chimici o in altre situazioni dove può esserne compromesso il buon funzionamento, è indicato l'utilizzo di tenute. In presenza di lubrificazioni saltuarie è preferibile utilizzare come lubrificante del grasso, al contrario se la lubrificazione è continua è consigliabile l'utilizzo d'olio. Nel caso di lubrificazione con grasso è opportuno utilizzare boccole con apposite tasche contenenti il grasso lubrificante, per lubrificazione ad olio la superficie liscia è consigliabile. I casi più frequenti riguardano la lubrificazione saltuaria a grasso nei quale è possibile utilizzare due diverse tipologie di boccole, con tasche a losanga, che permettono una lubrificazione con grasso ed intervalli di lubrificazione più lunghi, mentre utilizzando le boccole con tasche a calotta, è possibile inoltre la lubrificazione con olio, anche se gli intervalli saranno più brevi rispetto alla lubrificazione effettuata con grasso, che tra l'altro viene rilasciato ottimamente anche dalle boccole con tasche a calotta. Per la lubrificazione è indicato un grasso base al sapone di litio.

4.2 Lubrication

For proper functioning of these bushings, the lubrication is determining factor as it prevents deterioration both of the bushing as well as the counterering piece used as a plain for running. Once the bushing is exposed to chemical agents or in other situations where the proper functioning can be compromised a shield is indicated.

When lubricated sporadically a grease lubricant is indicated, on the contrary, if the lubrication is continuous an oil is recommended.

In the case of grease lubricating the bushing with the specific cap containing the lubricating grease whereas when using oil to lubricate a smooth surface is advisable.

In more frequent cases when lubrication is sporadic, grease when it is possible to use two different types of bushings, with lozenge cap pockets, that permit a grease lubrication at longer intervals, while using the spherical cap pockets bushings, is possible even with oil lubrication, when the intervals will be brief compared to the lubrication effected with grease, which in addition, can be left in an excellent way even when the spherical cap is used. For this lubrication a soap based grease with litio is indicated.

090 - 092

Diametro esterno Outer diameter D	Tolleranze diametro esterno Outer diameter tolerances D	Tolleranze spessore Thickness tolerances S _B		Dimensioni smusso Chamfer dimensions S _B f ₁ f ₂		
≤ 10	+0,055 +0,025	-	-	0,75	0,5 ± 0,3	-0,05 -0,30
10 < ≤ 18	+0,065 +0,030	1	+0,005 -0,020	1	0,6 ± 0,4	-0,1 -0,4
18 < ≤ 30	+0,075 +0,035	1,5	+0,005 -0,025	1,5	0,6 ± 0,4	-0,1 -0,6
30 < ≤ 50	+0,085 +0,045	2	+0,005 -0,030	2	1,2 ± 0,4	-0,1 -0,7
50 < ≤ 80	+0,100 +0,055	2,5	D ≤ 80 +0,005 -0,040	2,5	1,8 ± 0,6	-0,2 -1,0
80 < ≤ 120	+0,120 +0,070	2,5	80 < D ≤ 120 -0,010 -0,060	2,5	1,8 ± 0,6	-0,2 -1,0
120 < ≤ 180	+0,170 +0,100	2,5	D > 120 -0,035 -0,085	2,5	1,8 ± 0,6	-0,2 -1,0
180 < ≤ 305	+0,255 +0,125	2,5	D > 120 -0,035 -0,085	2,5	1,8 ± 0,6	-0,2 -1,0



Tolleranze di montaggio raccomandate:		Recommended mounting tolerances:	
Albero:	Foro:	Shaft:	Bore:
≤ 4 = h 6	≤ 4 = H 6	≤ 4 = h 6	≤ 4 = H 6
da 5 a 75 = f7	> 4 = H 7	from 5 to 75 = f7	> 4 = H 7
≥ 80 = h 8		≥ 80 = h 8	

Le tolleranze delle boccole 090 - 092 rispettano la norma ISO 3547-1:2006

Tolerance values of bushings 090 and 092 comply with standard ISO 3547-1:2006

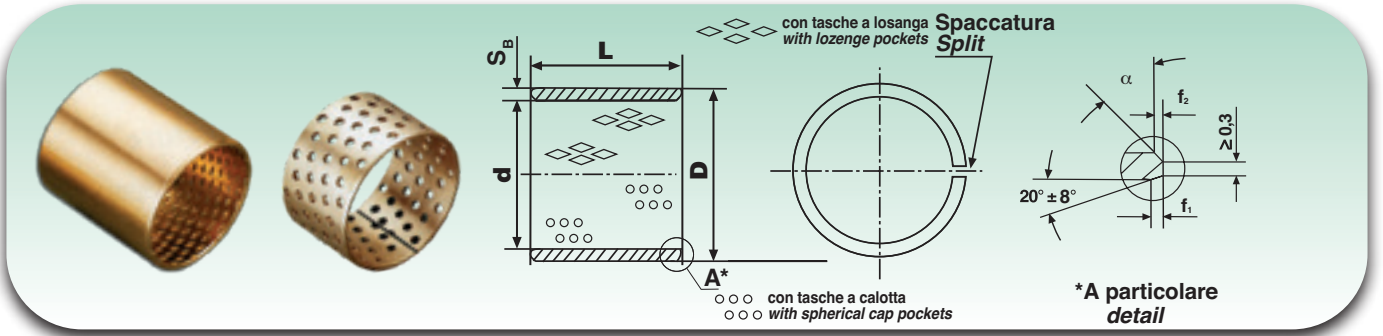

Di dimensioni (mm) Dimensions (mm)		
d	D	L ±0,25
10	12	10
		15
		20
12	14	10
		15
		20
13	15	10
		15
		20
		25
14	16	10
		15
		20
		25
		30
15	17	10
		15
		20
		25
16	18	10
		15
		20
		25
		30
17	19	10
		15
		20
		25
		30
18	20	10
		15
		20
		25
		30
18	21	10
		15
		20
		25
20	22	10
		15
		20
		25
		30
20	23	10
		15
		20
		25
		30
22	25	10
		15
		20
		25
		30

Dimensioni (mm) Dimensions (mm)		
d	D	L ±0,25
22	25	15
		20
		25
		30
		40
24	27	15
		20
		25
		30
		40
24	28	15
		20
		25
		30
		40
25	28	15
		20
		25
		30
		40
28	30	15
		20
		25
		30
		40
28	31	15
		20
		25
		30
		40
28	32	15
		20
		25
		30
		40
30	34	15
		20
		25
		30
		35
30	34	40
		45
		50
		60
		80
32	36	15
		20
		25
		30
		35
32	36	40
		50
		60
		80
		100

Dimensioni (mm) Dimensions (mm)		
d	D	L ±0,25
32	36	60
		80
35	39	15
		20
		25
		30
		35
40	44	40
		50
		60
		80
		100
45	50	40
		50
		60
		80
		100
50	55	20
		25
		30
		35
		40
55	60	20
		25
		30
		35
		40
60	65	25
		30
		35
		40
		50
60	65	60
		70
		80
		100
		120



mayoral
Suministros Industriales y Servicios

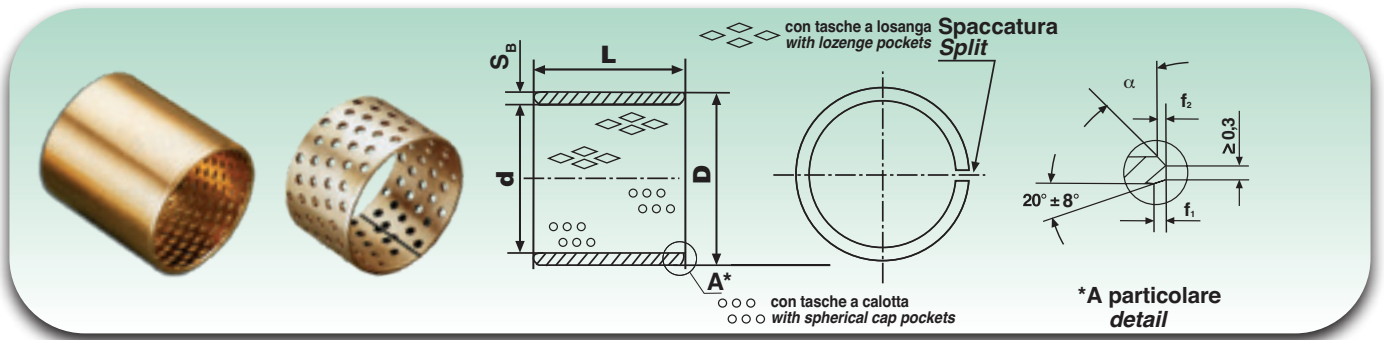

Dimensioni (mm) Dimensions (mm)				
d	D	L ± 0,25		
60	65	90		
65	70	25		
		30		
		35		
		40		
		50		
		60		
		70		
70	75	80		
		25		
		30		
		35		
		40		
		50		
		60		
		70		
		80		
		90		
75	80	25		
		30		
		35		
		40		
		50		
		60		
		70		
		80		
		100		
		80	85	30
35				
40				
50				
60				
70				
80				
100				
85	90			30
				35
		40		
		50		
		60		
		70		
		80		
90	95	30		
		35		
		40		
		50		
		60		
		60		

Dimensioni (mm) Dimensions (mm)		
d	D	L ± 0,25
90	95	70
		80
		90
		95
		100
		100
95	100	30
		40
		50
		60
		70
		80
		90
		95
		100
		100
105	110	30
		40
		50
		60
		70
		80
		90
		100
		100
		200
110	115	50
		60
		70
		80
		90
		100
		100
115	120	50
		60
		70
		80
		90
		100
		100
120	125	50
		60
		70
		80
		90
		100

Dimensioni (mm) Dimensions (mm)		
d	D	L ± 0,25
125	130	60
		70
		80
		90
		100
		100
130	135	60
		70
		80
		90
		100
		100
135	140	60
		70
		80
		90
		100
		100
140	145	60
		70
		80
		90
		100
		100
145	150	60
		70
		80
		90
		100
		100
150	155	50
		60
		70
		80
		90
		100
155	160	60
		70
		80
		90
		100
		100
160	165	60
		70
		80
		90
		100
		100
165	170	60
		70
		80
		90
		100
		100
170	175	60
		70
		70

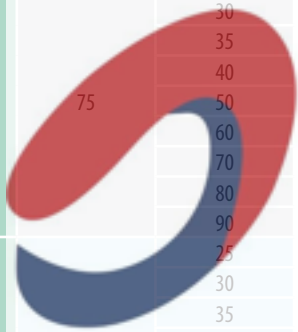

mayoral
Suministros Industriales y Servicios

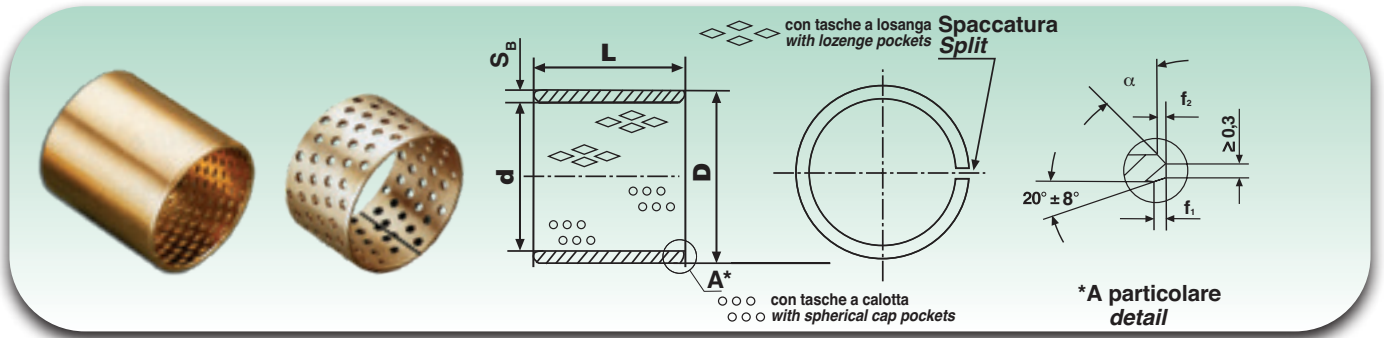

Dimensioni (mm) Dimensions (mm)		
d	D	L ± 0,25
170	175	80
		90
		100
175	180	60
		70
		80
		90
		100
180	185	60
		70
		80
		90
		100
		190
185	190	60
		70
		80
		90
		100
		100
190	195	60
		70
		80
		90
		100
195	200	60
		70
		80
		90
		100
200	205	60
		70
		80
		90
		100
205	210	60
		70
		80
		100

Dimensioni (mm) Dimensions (mm)		
d	D	L ± 0,25
210	215	60
		80
		100
215	220	60
		70
		80
		90
		100
		100
220	225	60
		80
		100
		100
225	230	60
		70
		80
		90
		100
		100
230	235	60
		70
		80
		90
		100
235	240	80
		100
		100
240	245	60
		70
		80
		90
		100
		100
245	250	60
		80
		100
		100
		100
250	255	60
		70
		80
		90
		100
255	260	60

Dimensioni (mm) Dimensions (mm)		
d	D	L ± 0,25
255	260	80
		100
260	265	60
		70
		80
		90
		100
		100
265	270	60
270	275	80
		100
		60
		70
		80
		90
275	280	60
		80
		100
		100
		100
280	285	60
285	290	80
		100
		100
		100
290	295	60
		70
		80
		90
		100
		100
295	300	60
		80
		100
300	305	60
		70
		80
		90
		100

Su richiesta, disponibili con tasche a losanga ed a calotta

Lozenge and spherical cap pockets are available on request

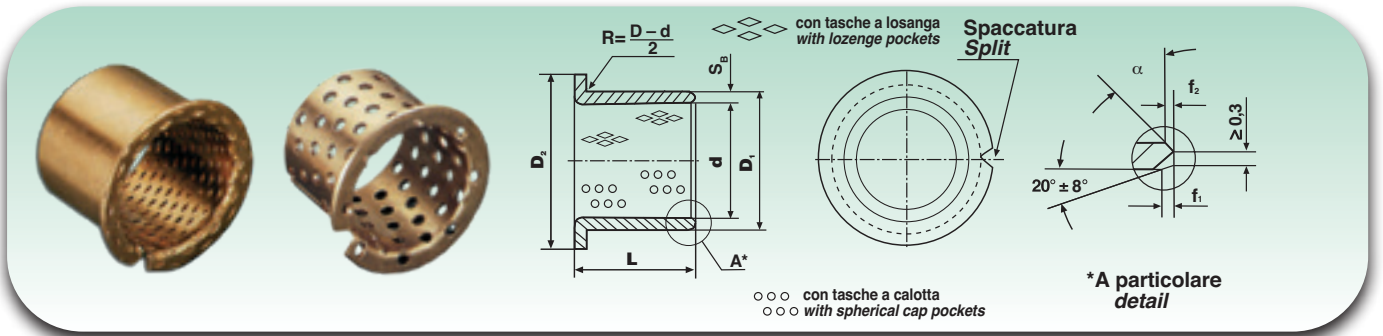

Sigla Designation	Dimensioni (mm) Dimensions (mm)			
	d	D ₁	D ₂ ± 0,50	L ± 0,25
F 12-15	12	14	20	15
F 20-15				15
F 20-20	20	23	30	20
F 25-15				15
F 25-20	25	28	35	20
F 25-25				25
F 30-15				15
F 30-20				20
F 30-25	30	34	45	25
F 30-30				30
F 35-20				20
F 35-25				25
F 35-30	35	39	50	30
F 35-35				35
F 35-45				45
F 40-25				25
F 40-30	40	44	55	30
F 40-35				35
F 40-40				40
F 45-30				30
F 45-35				35
F 45-40	45	50	60	40
F 45-45				45
F 45-50				50
F 45-60				60
F 50-30				30
F 50-35	50	55	65	35
F 50-40				40
F 50-50				50
F 55-20				20
F 55-25				25
F 55-30	55	60	70	30
F 55-35				35
F 55-40				40
F 55-50				50
F 60-20				20
F 60-25				25
F 60-30				30
F 60-35	60	65	75	35
F 60-40				40
F 60-45				45
F 60-50				50
F 60-60				60
F 65-30				30
F 65-35	65	70	80	35
F 65-40				40

Sigla Designation	Dimensioni (mm) Dimensions (mm)			
	d	D ₁	D ₂ ± 0,50	L ± 0,25
F 65-50				50
F 65-60	65	70	80	60
F 70-35				35
F 70-40				40
F 70-50	70	75	85	50
F 70-60				60
F 70-70				70
F 75-35				35
F 75-40				40
F 75-50	75	80	90	50
F 75-60				60
F 75-70				70
F 80-35				35
F 80-40				40
F 80-50	80	85	100	50
F 80-60				60
F 80-70				70
F 80-80				80
F 90-40				40
F 90-50				50
F 90-60	90	95	110	60
F 90-70				70
F 90-80				80
F 90-90				90
F 100-35				35
F 100-50				50
F 100-60	100	105	120	60
F 100-70				70
F 100-80				80
F 100-90				90
F 110-50				50
F 110-60				60
F 110-70	110	115	130	70
F 110-80				80
F 110-90				90
F 120-45				45
F 120-50				50
F 120-60	120	125	140	60
F 120-70				70
F 120-80				80
F 120-90				90
F 130-60				60
F 130-70	130	135	155	70
F 130-80				80
F 130-90				90
F 140-60	140	145	165	60

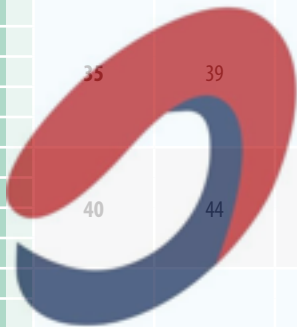

mayoral
Suministros Industriales y Servicios

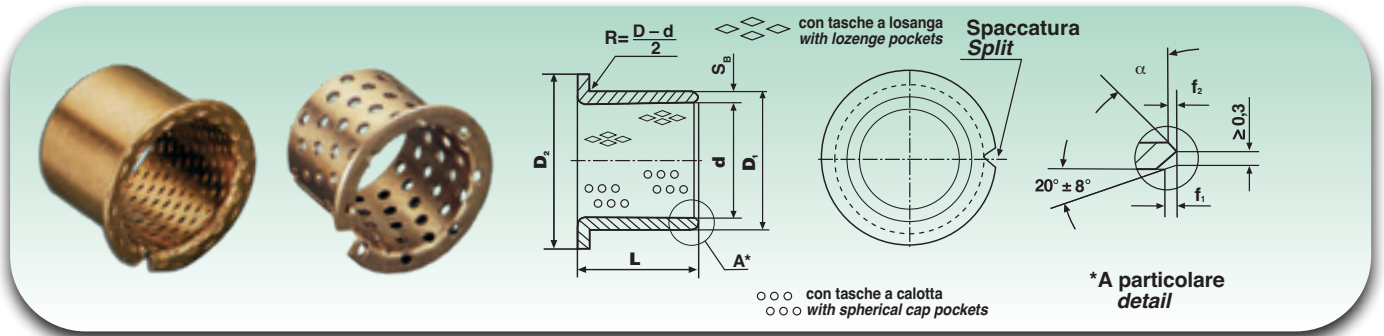

Sigla Designation	Dimensioni (mm) Dimensions (mm)			
	d	D ₁	D ₂ ± 0,50	L ± 0,25
F 140-70	140	145	165	70
F 140-80				80
F 140-90				90
F 150-50	150	155	180	50
F 150-60				60
F 150-70				70
F 150-80				80
F 150-90	90			
F 160-60	160	165	190	60
F 160-70				70
F 160-80				80
F 160-90				90
F 170-60	170	175	200	60
F 170-70				70
F 170-80				80
F 170-90	90			
F 180-60	180	185	215	60
F 180-70				70
F 180-80				80
F 180-90				90
F 190-60	190	195	225	60
F 190-70				70
F 190-80				80
F 190-90				90

Sigla Designation	Dimensioni (mm) Dimensions (mm)			
	d	D ₁	D ₂ ± 0,50	L ± 0,25
F 200-60	200	205	235	60
F 200-70				70
F 200-80				80
F 200-90				90
F 225-60	225	230	260	60
F 225-70				70
F 225-80				80
F 225-90				90
F 250-60	250	255	290	60
F 250-70				70
F 250-80				80
F 250-90				90
F 265-60	265	270	305	60
F 265-70				70
F 265-80				80
F 265-90	90			
F 285-60	285	290	325	60
F 285-70				70
F 285-80				80
F 285-90				90
F 300-60	300	305	340	60
F 300-70				70
F 300-80				80
F 300-90				90

Per ordinare specificare: 090 + sigla + tipo di tasca

To order, please specify: 090 + designation + pockets type

Su richiesta disponibili con tasche a losanga ed a calotta

Lozenge and spherical cap pockets are available on request

1) Su richiesta disponibili **RALLE TIPO 090**, con tasche a losanga.
Per le misure metriche (vedere a pagina 11), per le misure in pollici (vedere a pagina 18)

1) On request available also **WASHERS TYPE 090**, with lozenge pockets.
For metric dimensions, please (see page 11) and for inch dimensions, please (see page 18).

1) Per ordinare specificare: ralle 090 + d₄

1) To order, please specify: 090 washers + d₄

Per le dimensioni si rimanda alle tabelle di pagina 52-53-54 (boccole cilindriche) e pagina 55-56 (boccole flangiate).

Please find dimensions on pages from 52 to 54 (cylindrical bushings) and pages 55-56 (flanged bushings).

2) Per ordinare specificare: 092 + cilindriche o flangiate + dimensioni

2) To order, please specify: 092 + cylindrical or flanged + dimensions

5. Caratteristiche boccole bimetalliche BM

Le boccole bimetalliche BM sono costituite da due strisce metalliche di diverso materiale; una prima normalmente in acciaio, una seconda costituita da una lega contenente rame, che applicato alla striscia in acciaio funge così da rivestimento interno.

La particolare costruzione di queste boccole consente loro di avere una buona resistenza all'usura, in particolare a media velocità e medio carico o bassa velocità con grande carico.

La superficie interna può essere dotata di scanalature di diversi tipi che servono per la lubrificazione (fig. 6), realizzate per poter soddisfare le diverse applicazioni e condizioni di lubrificazione in cui le boccole possono essere utilizzate. Inoltre in alcune misure è presente anche un foro esterno di rilubrificazione.

5. BM bimetal bushings characteristics

The bimetal bushings BM are constituted of two metallic strips of different material; the first is normally in steel while the second is made by a copper alloy. The metals are coupled so that the non steel strip is the internal covering. The particular construction of these bushings, permits them to have good resistance to wear, in particular at medium speed and medium load or low speed with high load.

The internal surface of bronze can be channelled with different types of channels (fig. 6) depending on and conditions of lubrication in which the bushings can be used. Furthermore, in some cases, an external hole is present for re-lubricating.

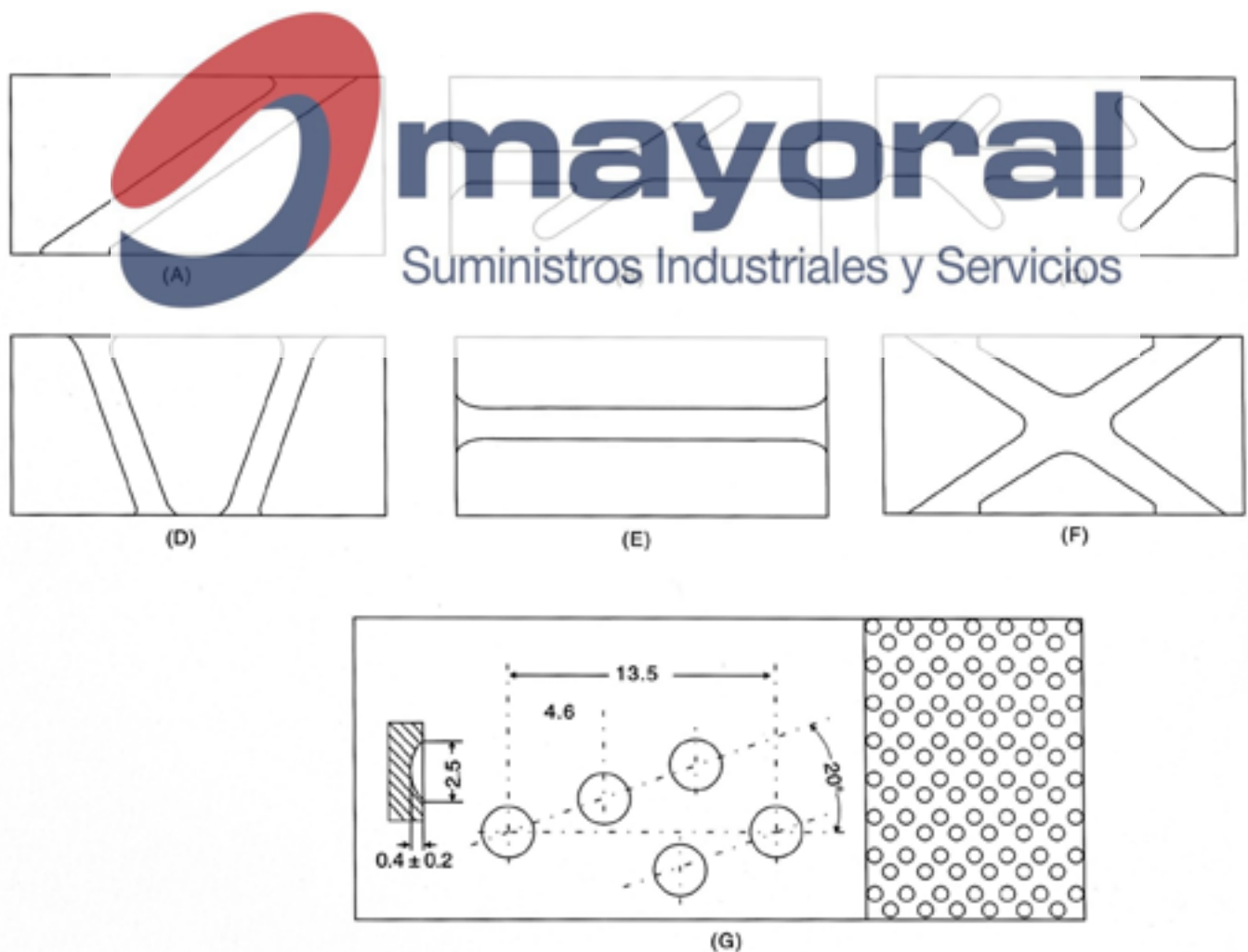

Fig. 6

Disponibili nei vari formati cilindrico, flangiata ed a ralla, alcune di queste boccole possono presentarsi aperte con un tipo di giunto (fig. 7).

Available in various cylindrical formats, flanged and washer, some of these bushings can be open with a type of joint (fig. 7).

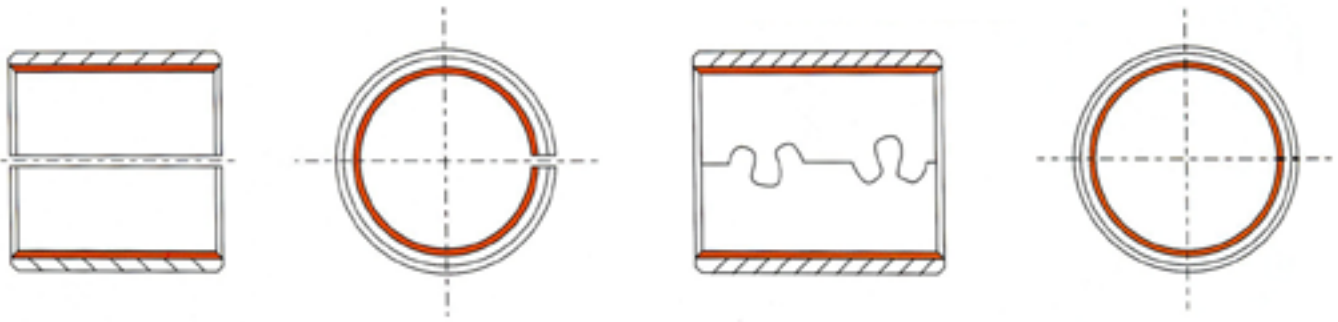

Fig. 7

Le principali applicazioni delle boccole bimetalliche, sono: l'automotive (motori, frizioni di motocicli, telai, smontagomme ecc...), nelle macchine agricole, per il sollevamento (gru idrauliche, ponti sollevatori, ecc...) nelle pompe, nei compressori.

The principal applications of the bimetel bushings are: automotive, (motors, motorcycle dutches, circular knitters, tire removes etc...), agricultural machinery, for lifting (hydraulic cranes, lifting bridges, etc...) pumps, compressor.



5.1 Caratteristiche tecniche



5.1 Technical features

Descrizione <i>Description</i>	Tipologie delle leghe di bronzo - <i>Bronze alloys types</i>			
	BM 1 CuPb10Sn10	BM 2 CuPb24Sn4	BM 3 CuPb30	BM 4 AlSn20Cu
Carico limite (N/mm ²) <i>Load limit (N/mm²)</i>	150	130	120	100
Resistenza alla trazione (N/mm ²) <i>Tensile strength (N/mm²)</i>	185	150	200	200
Velocità massima* (m/s) <i>Max speed* (m/s)</i>	5	10	15	25
Coefficiente di frizione (µm) <i>Friction coefficient (µm)</i>	0,06 ~ 0,14	0,06 ~ 0,16	0,08 ~ 0,16	0,08 ~ 0,17
Pv max (N/mm ²) • (m/s) <i>Grasso - Grease</i>	2,8	2,8	2,5	/
Pv max (N/mm ²) • (m/s) <i>Olio - Oil</i>	10	10	8	6

* con lubrificazione a olio *with oil lubrication

5.2 Specifica dei materiali

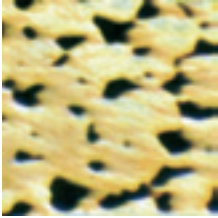
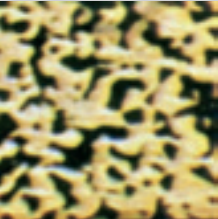
5.2 Material specifications

Lega Alloy	Durezza Hardness	Temperatura Temperature	Metallografia Metallographic	Caratteristiche Characteristics
BM 1 CuPb10Sn10	70 ~ 100 HB	+260 °C		La tipologia con la maggiore durezza, vasti campi di applicazione, la più indicata per boccole e ralle con elevati carichi vibrazionali e che richiedono elevata resistenza agli urti. <i>The type with highest hardness, wide application field, most suitable for high impact vibrating load bushings and washers.</i>
BM 2 CuPb24Sn4	45 ~ 70 HB	+200 °C		Resistenza a fatica e capacità di carico relativamente alte, buona capacità di rotolamento, ma bassa resistenza alla corrosione in ambienti oleosi, adatte per medi carichi e velocità. Tipologia normalmente utilizzata per boccole in motori a combustione interna e in bielle (se placcate). <i>Relative high fatigue strength and load capacity, good sliding performance, poor oil corrosion resistance, fit for middle load/ middle speed. Normally applied in bushings for inner-combustion engines, connecting rods (when plated).</i>
BM 3 CuPb30	30 ~ 45 HB	+170 °C		Tipologia con buona resistenza all'affaticamento, normalmente utilizzata in boccole ad elevata velocità. Adatta per boccole in motori a combustione interna e in bielle in presenza di basso o medio carico. <i>Good fatigue strength, normally applied in high speed bushings. Applied in bushings for inner-combustion engines and connecting rods with low to moderate load.</i>
BM 4 AlSn20Cu	30 ~ 40 HB	+150 °C		Moderata resistenza a fatica e capacità di carico, buona resistenza alla corrosione. Adatta per boccole in motori a combustione interna con bassi carichi, compressori ad aria, refrigeratori. <i>Moderate fatigue strength and load capacity, good corrosion resistance, applied in bushings for inner-combustion engines with low load, air compressors, refrigerators.</i>

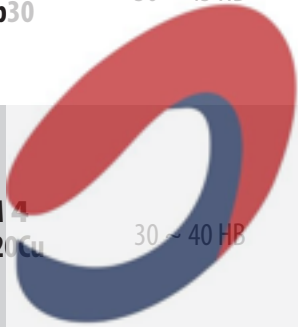

mayoral
Suministros Industriales y Servicios

BM

Diametro esterno <i>Outer diameter</i>		Tolleranze diametro esterno <i>Outer diameter tolerances</i>	Tolleranze spessore <i>Thickness tolerances</i>		Dimensioni smusso <i>Chamfer dimensions</i>		
D		D	S _B		S _B	f ₁	f ₂
10 <	≤ 17	+0,065 +0,030	1	0 -0,025	1	0,5	0,3
17 <	≤ 20	+0,075 +0,035	1	0 -0,025	1	0,8	0,4
20 <	≤ 25	+0,075 +0,035	1,5	0 -0,030	1,5	0,8	0,4
25 <	≤ 28	+0,075 +0,035	1,5	0 -0,030	1,5	1	0,5
28 <	≤ 30	+0,075 +0,035	2	0 -0,035	2	1	0,5
30 <	≤ 32	+0,085 +0,045	2	0 -0,035	2	1	0,5
32 <	≤ 44	+0,085 +0,045	2	0 -0,035	2	1,2	0,6
44 <	≤ 50	+0,085 +0,045	2,5	0 -0,040	2,5	1,5	1
50 <	≤ 80	+0,100 +0,055	2,5	0 -0,040	2,5	1,5	1
80 <	≤ 85	+0,120 +0,070	2,5	0 -0,040	2,5	1,5	1
85 <	≤ 120	+0,120 +0,070	3	0 -0,045	3	1,8	1,2
120 <	≤ 125	+0,170 +0,100	3	0 -0,045	3	1,8	1,2
125 <	≤ 180	+0,170 +0,100	3,5	0 -0,050	3,5	2	1,5



mayoral
Suministros Industriales y Servicios

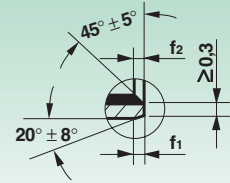
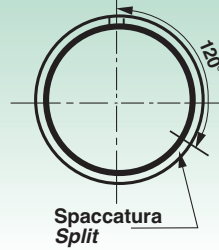
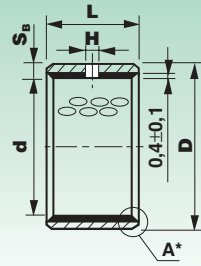

*A particolare detail

Dimensioni (mm) Dimensions (mm)			
d	D	L ^{0,40}	H
10	12	10	4
		15	
		20	
		25	
12	14	10	4
		15	
		20	
		25	
13	15	10	4
		15	
14	16	10	4
		15	
		20	
15	17	10	4
		15	
		20	
16	18	10	4
		15	
		20	
		25	
16	22	15	4
		20	
17	19	10	4
		15	
		20	
		25	
18	20	10	4
		15	
		20	
		25	
20	22	10	4
		15	
		20	
		25	
20	23	10	4
		15	
		20	
		25	
		30	
22	25	10	6
		15	
		20	
		25	
		30	

Dimensioni (mm) Dimensions (mm)			
d	D	L ^{0,40}	H
24	27	10	6
		15	
		20	
		25	
		30	
24	28	15	6
		20	
		25	
		30	
		30	
25	28	15	6
		20	
		25	
		30	
25	32	15	6
		20	
		25	
26	30	15	6
		20	
		25	
		30	
28	32	15	6
		20	
		25	
		30	
30	34	15	6
		20	
		25	
		30	
		40	
32	36	15	6
		20	
		25	
		30	
		40	
33	37	30	6
		30	
35	39	20	6
		25	
		30	
		35	
		40	
		50	
38	42	20	-
		25	
		30	
		40	
		50	
		50	
40	44	20	8
		25	
		30	
		40	
		50	
		50	

Dimensioni (mm) Dimensions (mm)			
d	D	L ^{0,40}	H
45	50	20	8
		25	
		30	
		40	
		45	
50	55	20	8
		30	
		40	
50	60	14	8
		20	
		30	
		40	
55	60	30	8
		40	
		50	
		60	
		60	
65	70	30	8
		40	
		50	
		60	
		70	
70	75	30	8
		40	
		50	
		60	
		70	
		80	
75	80	30	9,5
		40	
		50	
		60	
		70	
		80	
80	85	40	9,5
		50	
		60	
		80	
		100	
		100	
85	90	30	9,5
		60	
		100	
90	95	60	9,5
		100	

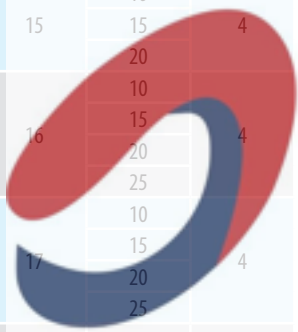

mayoral
Suministros Industriales y Servicios

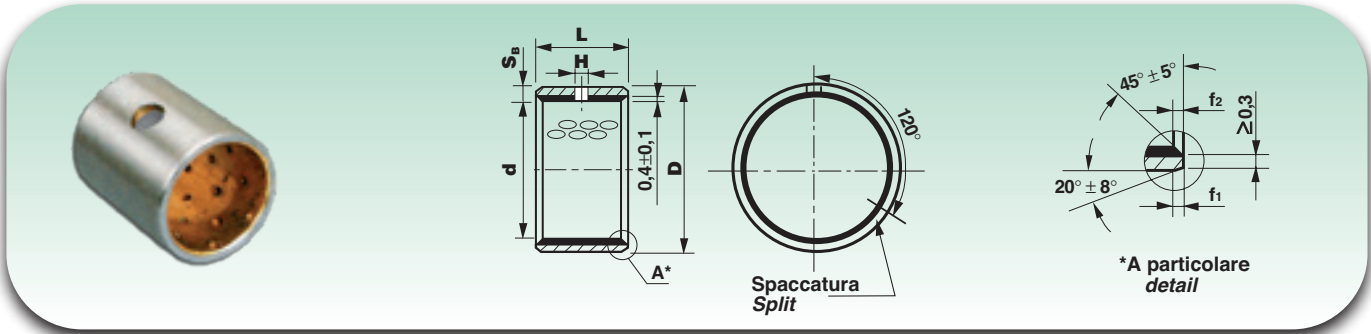

Dimensioni (mm) Dimensions (mm)			
d	D	L ⁰ _{-0,40}	H
95	100	60	9,5
		100	
100	105	60	9,5
		100	
		115	
105	110	60	9,5
		100	
		115	
110	115	60	9,5
		100	
		115	
115	120	50	9,5
		60	
		70	
		100	
120	125	50	9,5
		60	
		100	
125	130	60	9,5
		60	
		100	

Dimensioni (mm) Dimensions (mm)			
d	D	L ⁰ _{-0,40}	H
130	135	60	9,5
		100	
135	140	60	9,5
		80	
		100	
140	145	60	9,5
		100	
		60	
145	150	80	9,5
		100	
		60	
150	155	60	-
		100	
		60	
155	160	60	-
		100	
		60	
160	165	60	-
		100	
		60	
165	170	60	-
		100	
		60	
170	175	60	-
		100	
		60	
175	180	60	-
		100	
		100	

Dimensioni (mm) Dimensions (mm)			
d	D	L ⁰ _{-0,40}	H
180	185	60	-
		100	
200	205	60	-
		100	
205	210	60	-
		100	
210	215	60	-
		100	
215	220	60	-
		100	
220	225	60	-
		100	
230	235	60	-
		100	
240	245	60	-
		100	
250	255	60	-
		100	
280	285	60	-
		100	
300	305	60	-
		60	
		100	

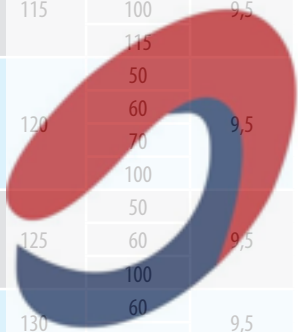

mayoral
Suministros Industriales y Servicios

Per ordinare specificare: BM + tipo 1/2/3/4 + d + L

To order, please specify: BM + type 1/2/3/4 + d + L

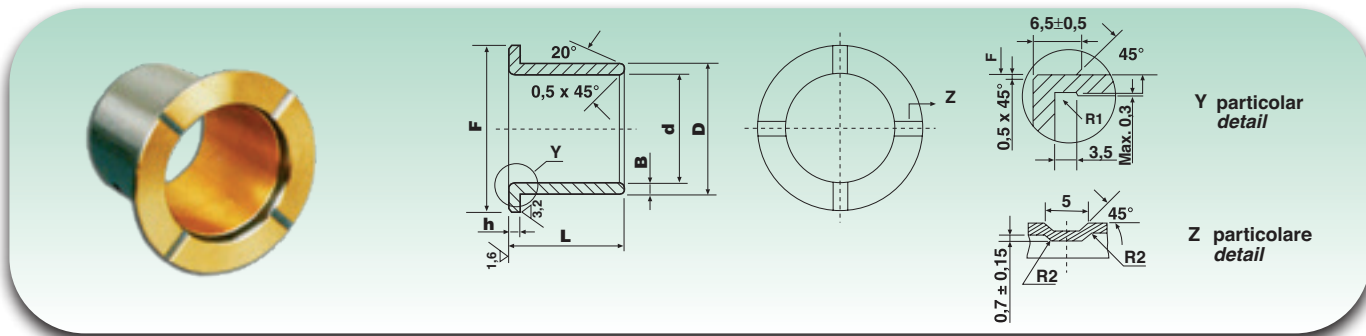

Dimensioni (mm) - <i>Dimensions (mm)</i>					
d $^{+0,20}$ $_{+0,15}$	D $^{+0,28}$ $_{+0,20}$	F $^{-0,50}$	L 0 $_{-0,40}$	h	B
40	46	60	39,5	3,5	3,0
	47	62	35	3,5	3,5
45	55	68	55	3,5	5,0
50	57	72	40	3,5	3,5
		70	50		
54	60,6	92	60	3,5	3,3
60	67	83	53	3,5	3,5
		87	60		
		77	65		
63,5	70,4	88	60	4,0	4,0
		87	65		
63,8	70,8	102,6	73	3,5	3,5
65	72	85	53	3,5	3,5
		87	64		
70	77	108	75	3,5	3,5
		93	60		
75	80	108	90	5,0	5,0
		100	60		
80	87	100	68	3,5	3,5
		127	80		
85	92	127	80	3,5	3,5
		128	103,5		
89,2	97,5	138	126,5	4,2	4,2
95	105	144	127	5,0	5,0

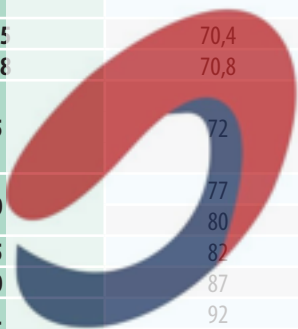

mayoral
Suministros Industriales y Servicios

Per ordinare specificare: BM + tipo 1/2/3/4 F + d + D + F

To order, please specify: BM + type 1/2/3/4 F + d + D + F

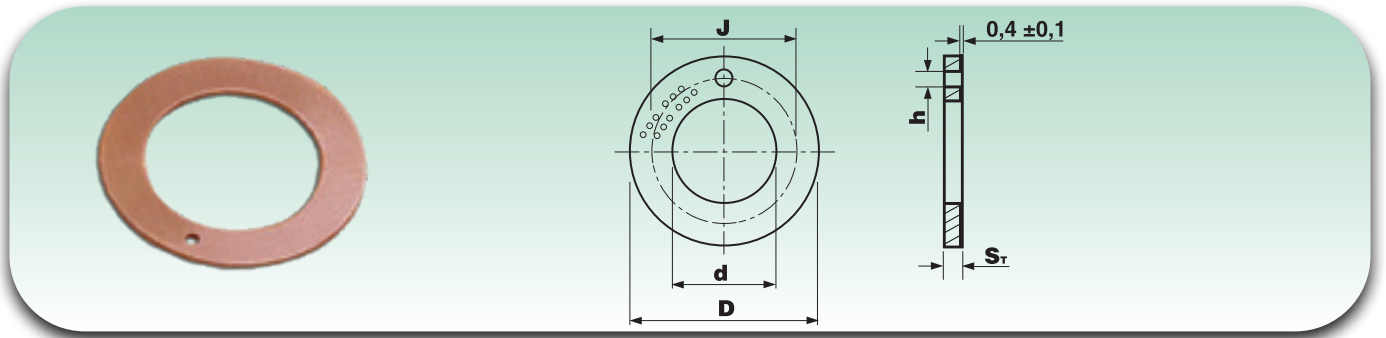

Dimensioni (mm) - Dimensions (mm)

$d^{+0,25}_0$	$D^0_{-0,25}$	$S_T^0_{0,05}$	$J^{\pm 0,12}$	$h^{+0,4}_{+0,1}$
10	20	1,5	16	1,5
12	24	1,5	18	1,5
14	26	1,5	20	2
16	30	1,5	23	2
18	32	1,5	25	3
20	36	1,5	28	3
22	38	1,5	30	3
24	42	1,5	33	3
26	44	1,5	35	4
28	48	1,5	38	4
32	54	1,5	43	4
38	62	1,5	50	4
42	66	1,5	54	4
48	74	2	61	4
52	78	2	65	4
62	90	2	76	4

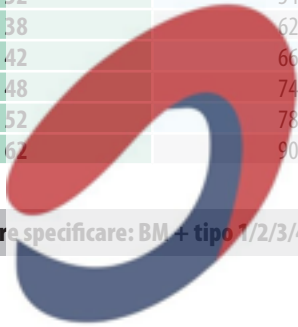

mayoral

Suministros Industriales y Servicios

Per ordinare specificare: BM + tipo 1/2/3/4 R + d

To order, please specify: BM + type 1/2/3/4 R + d

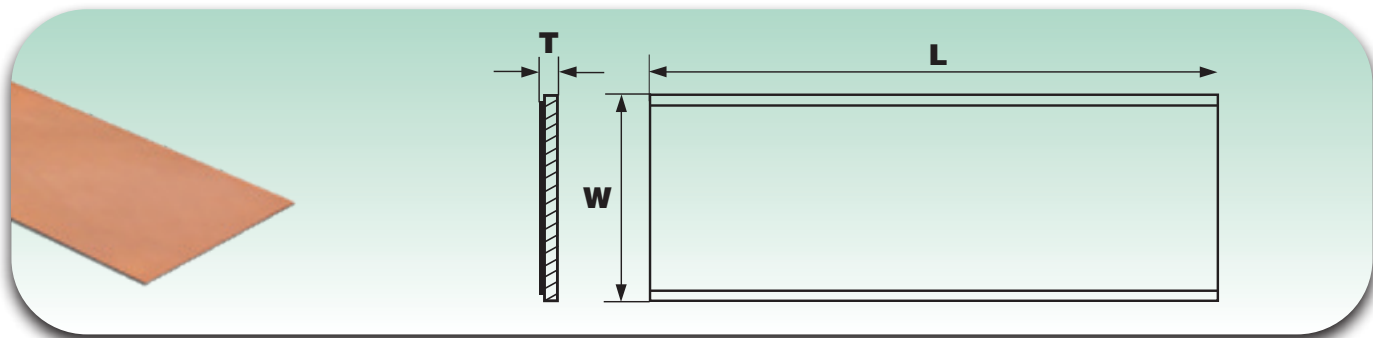

Sigla Designation	Dimensioni (mm) - Dimensions (mm)		
	Lunghezza Length L	Altezza Width W	Spessore Thickness T - 0,05
NSTR-BM 050.15	500	150	1,5
NSTR-BM 050.20	500	150	2,0
NSTR-BM 050.25	500	150	2,5

Per ordinare specificare: sigla + tipo 1/2/3/4

To order, please specify: designation + type 1/2/3/4





6. Caratteristiche boccole con lubrificante solido BG

Questo particolare tipo di boccia è caratterizzata da una struttura base costruita in bronzo (BG2) con alveoli riempiti da materiale lubrificante solido, normalmente grafite. Il materiale di costruzione delle boccole può essere inoltre ottone (BG1), ghisa (BG4), acciaio (BG5), ed anche in lega bimetallica (BG3) su richiesta.

La particolare struttura così combinata, grazie alla sua capacità di autolubrificazione, permette una lunga durata dell'applicazione, garantendo pertanto elevate prestazioni nel tempo.

Queste caratteristiche diventano importanti in particolar modo a fronte di applicazioni che presentano le sotto indicate condizioni:

- impossibilità d'effettuare la lubrificazione dall'esterno
- occorre montare una boccia standard autolubrificante
- la temperatura d'esercizio è molto bassa o molto alta.

Le boccole con lubrificante solido vengono impiegate soprattutto nell'industria metallurgica, nelle macchine per il settore minerario, nell'industria navale, nelle turbine idrauliche ed in ambienti dove sono presenti agenti corrosivi o altre sostanze chimiche.

Anche queste boccole, sono normalmente disponibili in formato: cilindrico, flangiato, a ralla ed in piastre scorrevoli.

6. BG bushings with solid lubricant characteristics

This particular type of bushings is characterized by a base structure constructed in bronze (BG2) with sockets filled with solid lubricants, normally graphite. The construction material of the bushings can be also brass (BG1), cast iron (BG4), steel (BG5), and even in bimetal alloy (BG3) if requested.

This particular combination, thanks to its self-lubrication, permits a long duration in the application, guaranteeing as well high performance over time.

These characteristics become particularly important during applications which present the conditions indicated below:

- external lubrication is not possible
- a standard self-lubricating bushing is required to be mounted.
- the operating temperature is very low or very high.

The bushings with solid lubricant is used especially in the metallurgic industry, in machines for the field of mining, in the naval industry, in hydraulic turbines, and in environments with corrosive agents or other chemical substances.

These items are available as cylindrical and flanged bushings, thrust washers, and as sliding plates.



6.1 Caratteristiche tecniche

6.1 Technical features

Caratteristiche Characteristics	BG1	BG2	BG3	BG4	BG5
Composizione Composition	CuZn25Al6Fe3Mn3	CuSn6Zn6Pb3	Acciaio/Steel + CuSn6Zn6Pb3	GJL-250	100Cr6
Durezza Hardness	210 ~ 250 HB	80 ~ 120 HB	60 ~ 90 HB	180 ~ 230 HB	55 ~ 60 HRC (550 ~ 600 HB)
Temperatura max Max temperature	300° C	350° C	300° C	400° C	350° C
Carico max Max load	100 N/mm ²	60 N/mm ²	70 N/mm ²	60 N/mm ²	250 N/mm ²
Coefficiente d'attrito Friction coeff.	< 0,16	< 0,15	< 0,14	< 0,18	< 0,17
Velocità max (secco) Max speed (dry)	0,4 m/s	2 m/s	2 m/s	0,5 m/s	0,1 m/s
Velocità max (olio) Max speed (oil)	5 m/s	10 m/s	10 m/s	5 m/s	3 m/s
Pv massimo (secco) Max Pv (dry)	1,8 N/mm ² · m/s	0,5 N/mm ² · m/s	0,6 N/mm ² · m/s	0,8 N/mm ² · m/s	2,5 N/mm ² · m/s
Pv massimo (olio) Max Pv (oil)	3,8 N/mm ² · m/s	3,8 N/mm ² · m/s	3,8 N/mm ² · m/s	3,8 N/mm ² · m/s	3,8 N/mm ² · m/s

6.2 Specifica dei materiali

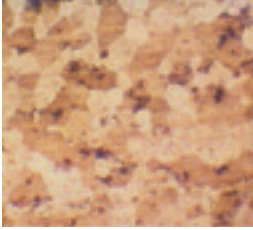
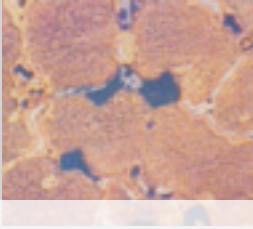
6.2 Material specifications

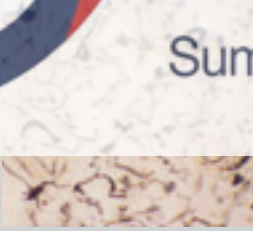
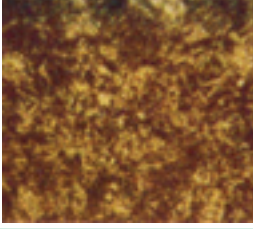
Lega Alloy	Metallografia Metallographic	Caratteristiche Characteristics
<p>BG 1 CuZn25Al6Fe3Mn3</p>		<p>Adatta per un uso generalizzato in varie circostanze con carichi o temperature sia basse che elevate, a secco o con lubrificazione a olio, persino in acqua. La sua composizione in ottone ad elevata durezza (doppia rispetto ad una normale boccia in bronzo) aumenta di gran lunga la resistenza a fatica, il che la rende adatta per macchinari per fusione a colata continua e nastri trasportatori per l'industria metallurgica. Può essere usata per macchine per stampaggio ad iniezione, negli interruttori automatici di corrente ad elevata tensione, attrezzature di sollevamento per macchinari da costruzione, tunnel di essiccazione nelle cartiere, parti scorrevoli nei sistemi per salpare l'ancora, ecc.</p> <p><i>Basically general-purpose products, suitable for various circumstances including high or low load, high or low temperature, with oil or oilless lubrication, or even in the water. Thanks to its matrix made of high strength brass, its hardness doubles that of normal bronze bushings, and the wear performance increases to a large extent, so that it is suitable for continuous casting machines, and conveyors for metallurgy industry. It could also be used in plastic injection machines, in the automatic switch of high tension electricity, in the luffing and supporting parts of construction machines, drying tunnel of paper machines, sliding parts for ship unmooring, etc.</i></p>
<p>BG 2 CuSn6Zn6Pb3</p>		<p>Tipologia adatta per situazione con bassi carichi ed elevate temperature, come ad esempio forni da panettiere, macchinari dell'industria leggera, attrezzature, ecc.</p> <p><i>Suitable for low load and high temperature applications, such as raceway of bakery, machines of light industry, machine tools industry, etc.</i></p>
<p>BG 3 Acciaio/Steel + CuSn6Zn6Pb3</p>		<p>La parte interna delle boccie BG3 è dello stesso materiale delle boccie BG2, quindi queste due tipologie hanno la stessa applicazione. In più, godono di alcuni vantaggi come il risparmio sul costo delle materie prime ed un'accresciuta resistenza alla compressione. Sono adatte per parti di macchinari per costruzione che non richiedono lubrificazione ad olio, macchine dell'industria metallurgica, e nastri trasportatori.</p> <p><i>The inner side of BG3 bushings is made of the same material of BG2 bushings, so they can be used in the same applications. Moreover, BG3 have some advantages, as saving on material costs, and improved compressive strength. They are suitable for parts of construction machines that don't need oil lubrication, metallurgy machines, and conveying machines.</i></p>
<p>BG 4 GJL-250</p>		<p>Le BG4 sono fatte in un tipico materiale che abbassa notevolmente i costi, pur garantendo però una consistente resistenza a compressione, quando non sono così elevate. Adatto per presse e macchinari per lo stampaggio.</p> <p><i>BG4 are made of a typical cost saving material. They could replace BG2 products where the mechanical requirements are not so high. They could reduce the cost largely, and meet the demands for application. Suitable for mould guide bushings, die carrier of plastic moulding machines, etc.</i></p>
<p>BG 5 100Cr6</p>		<p>Le BG5 sono fatte in un materiale rinforzato. Grazie alle loro eccellenti performance ad ampio spettro, sono adatte principalmente alle parti di supporto degli organi di sollevamento, come argani e gru. Ma essendo fatta in acciaio, non è adatta per applicazioni in acqua, con acidi o alcali.</p> <p><i>BG5 are a kind of fortified products. Due to their excellent comprehensive capabilities, they are especially suitable in the supporting parts of hoisting machines, e.g. support of roofer, hoist engine, crane, etc. But as for material being steel, they are not suitable for applications with water, acids, and alkali.</i></p>

BG1 - BG2 - BG4-AF

Diametro interno Inner diameter d	Tolleranze diametro interno Inner diameter tolerances d	Diametro esterno Outer diameter D	Tolleranze diametro esterno Outer diameter tolerances D
6 < ≤ 10	+ 0,028 + 0,013	10 < ≤ 18	+ 0,018 + 0,007
10 < ≤ 18	+ 0,034 + 0,016	18 < ≤ 30	+ 0,021 + 0,008
18 < ≤ 30	+ 0,041 + 0,020	30 < ≤ 50	+ 0,025 + 0,009
30 < ≤ 50	+ 0,050 + 0,025	50 < ≤ 80	+ 0,030 + 0,011
50 < ≤ 80	+ 0,060 + 0,030	80 < ≤ 120	+ 0,035 + 0,013
80 < ≤ 120	+ 0,071 + 0,036	120 < ≤ 180	+ 0,040 + 0,015
120 < ≤ 160	+ 0,083 + 0,043	-	-

BG1-F - BG2-F

Diametro interno Inner diameter d	Tolleranze diametro interno Inner diameter tolerances d	Diametro esterno Outer diameter D	Tolleranze diametro esterno Outer diameter tolerances D
6 < ≤ 10	+ 0,040 + 0,025	10 < ≤ 18	+ 0,034 + 0,023
10 < ≤ 18	+ 0,050 + 0,032	18 < ≤ 30	+ 0,041 + 0,028
18 < ≤ 30	+ 0,061 + 0,040	30 < ≤ 50	+ 0,050 + 0,034
30 < ≤ 50	+ 0,075 + 0,050	50 < ≤ 65	+ 0,060 + 0,041
50 < ≤ 80	+ 0,090 + 0,060	65 < ≤ 80	+ 0,062 + 0,043
80 < ≤ 120	+ 0,107 + 0,072	81 < ≤ 100	+ 0,073 + 0,051
-	-	101 < ≤ 120	+ 0,076 + 0,054
-	-	120 < ≤ 140	+ 0,088 + 0,063

BG4 - BG4-F

Diametro interno Inner diameter d	Tolleranze diametro interno Inner diameter tolerances d	Diametro esterno Outer diameter D	Tolleranze diametro esterno Outer diameter tolerances D
18 < ≤ 30	+ 0,021 0	30 < ≤ 50	± 0,008
30 < ≤ 50	+ 0,025 0	50 < ≤ 80	± 0,0095
50 < ≤ 80	+ 0,030 0	80 < ≤ 120	± 0,011
80 < ≤ 120	+ 0,035 0	120 < ≤ 140	± 0,0125

Tolleranze di montaggio raccomandate:

Recommended mounting tolerances:

Sede:
H7

Albero:
d8 (carico pesante)
e7 (carico leggero)
f7 (alta precisione)

Housing:
H7

Shaft:
d8 (high load)
e7 (low load)
f7 (high precision)

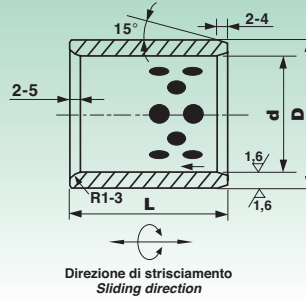

Dimensioni (mm) Dimensions (mm)		
$d_{(F7)}$	$D_{(m6)}$	$L_{-0,10/-0,30}$
8	12	8
		10
		12
		15
		16
10	14	8
		10
		12
		15
		20
12	18	8
		10
		12
		15
		16
		19
		20
		25
		30
		13
12		
15		
16		
20		
14	20	10
		12
		15
		20
		25
		30
		30
15	21	10
		12
		15
		16
		20
		25
		30
16	22	10
		12
		15
		16
		19
		20
		25
		30
17	23	15
18	24	12

Dimensioni (mm) Dimensions (mm)		
$d_{(F7)}$	$D_{(m6)}$	$L_{-0,10/-0,30}$
18	24	15
		16
		20
		25
		30
		35
19	26	15
		20
		10
		12
20	30	15
		16
		19
		20
		25
		30
		35
		40
		50
		60
22	32	12
		15
		20
		25
		30
25	33	12
		15
		16
		20
		25
		30
		35
		40
25	35	12
		15
		16
		20
		25
		30
		35
		40
		50
		60

Dimensioni (mm) Dimensions (mm)		
$d_{(F7)}$	$D_{(m6)}$	$L_{-0,10/-0,30}$
25	35	15
		16
		20
		25
		30
		35
28	38	40
		45
		50
		20
		25
30	36	30
		35
		40
		45
		50
		60
		20
		25
		30
		35
30	38	12
		15
		20
		25
		30
		35
		40
		45
30	40	12
		15
		20
		25
		30
		35
		40
		45

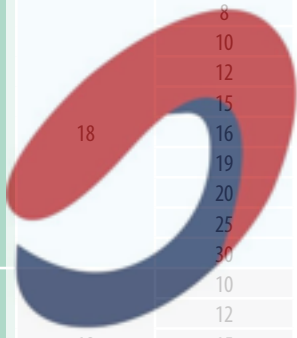

mayoral
Suministros Industriales y Servicios

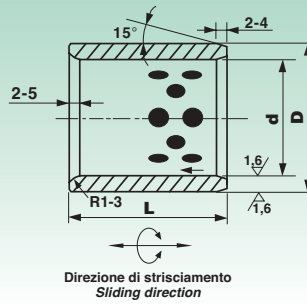

Dimensioni (mm) Dimensions (mm)		
$d_{(F7)}$	$D_{(m6)}$	$L_{-0,10/-0,30}$
30	40	60
31,5	42	30
		40
32	42	20
		30
		40
35	44	20
		25
		30
		35
		40
		45
35	45	50
		60
		20
		25
		30
		35
		40
		45
		50
		60
38	48	30
40	50	40
		15
		20
		25
		30
		35
		40
		45
		50
		60
		70
40	55	80
		15
		25
		30
		35
		40
		45
		50
45	55	60
		30
		35
		40
		45

Dimensioni (mm) Dimensions (mm)		
$d_{(F7)}$	$D_{(m6)}$	$L_{-0,10/-0,30}$
45	56	30
		35
		40
		45
		50
		60
		70
		80
		30
		35
45	60	40
		45
		50
		60
		70
		80
		20
		30
		35
		40
50	62	50
		60
		70
		80
		30
		35
		40
		45
		50
		60
50	65	70
		80
		100
		15
		25
		30
		35
		40
55	70	50
		60
		70
		80
		100
60	74	30
		35
		40
		45
		60

Dimensioni (mm) Dimensions (mm)		
$d_{(F7)}$	$D_{(m6)}$	$L_{-0,10/-0,30}$
60	74	40
		45
		50
		60
		70
		80
60	75	30
		35
		40
		45
		50
		60
63	75	70
		80
		50
		60
		70
		80
		60
		70
		80
		100
63	76	60
		70
		80
		40
		50
		60
		70
		80
		50
		60
65	80	60
		70
		80
		30
		35
		40
70	85	45
		50
		60
		70
		80
		100
		50
		60
70	90	70
		80
		50
		60
75	90	70
		80
		100
		60
75	95	70
		80
		100
		60

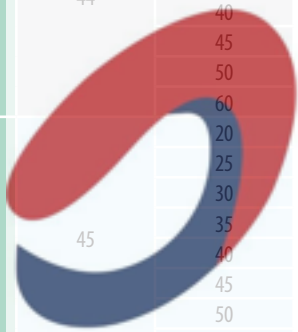

mayoral
Suministros Industriales y Servicios

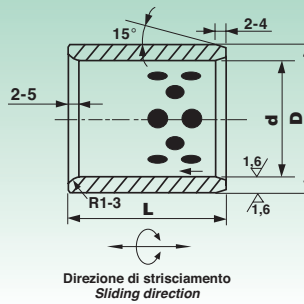

Dimensioni (mm) Dimensions (mm)		
$d_{(F7)}$	$D_{(m6)}$	L ^{-0,10 -0,30}
75	95	70
		80
		100
80	96	35
		40
		45
		50
		60
		70
		80
		100
80	100	40
		45
		50
		60
		70
		80
		100
		120
85	100	60
		80

Dimensioni (mm) Dimensions (mm)		
$d_{(F7)}$	$D_{(m6)}$	L ^{-0,10 -0,30}
90	100	40
		45
		50
		60
		70
		80
		100
		120
90	110	140
		60
		80
		100
100	110	120
		65
		50
		60
100	120	70
		80
		90
		120
110	130	140
		50

Dimensioni (mm) Dimensions (mm)		
$d_{(F7)}$	$D_{(m6)}$	L ^{-0,10 -0,30}
110	130	70
		80
		100
		120
120	140	70
		80
		90
		100
125	145	100
		120
		140
		140
130	150	80
		100
		130
		100
140	160	100
		140
		80
		100
150	170	150
		80
		100
160	180	150
		80
		100

mayoral
Suministros Industriales y Servicios

Per ordinare specificare: BG.. tipo 1/2/3/4/5 + d + D + L

To order, please specify: BG..type 1/2/3/4/5 + d + D + L

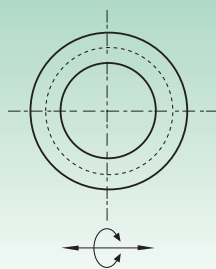

Direzione di strisciamento
Sliding direction

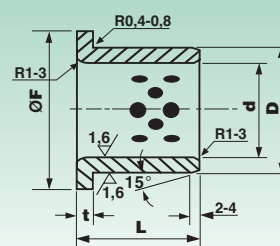

Dimensioni (mm) Dimensions (mm)				
$d_{(E7)}$	$D_{(r6)}$	F	$t \begin{smallmatrix} 0 \\ -0,1 \end{smallmatrix}$	$L \begin{smallmatrix} -0,10 \\ -0,30 \end{smallmatrix}$
8	12	20	2	10
				15
10	14	22	2	10
				12
				15
				17
				20
				25
12	18	25	3	10
				15
				20
				25
13	19	26	3	30
				10
				15
				20
14	20	27	3	15
				20
				25
15	21	28	3	10
				20
				25
				30
16	22	29	3	15
				18
				20
				23
				25
				30
				35
				40
18	24	32	3	20
				30
				15
20	28	40	5	20
				25
				30
				35
20	30	40	5	15
				20
				25
				30
				35
				40
25	33	45	5	15
				20
				25
				30
				30

Dimensioni (mm) Dimensions (mm)				
$d_{(E7)}$	$D_{(r6)}$	F	$t \begin{smallmatrix} 0 \\ -0,1 \end{smallmatrix}$	$L \begin{smallmatrix} -0,10 \\ -0,30 \end{smallmatrix}$
25	33	45	5	40
				15
25	35	45	5	20
				25
				30
				35
				40
				50
30	38	50	5	20
				25
				30
				35
				40
				50
30	40	50	5	20
				25
				30
				35
31,5	40	50	5	40
				20
				25
				30
35	45	60	5	35
				40
				20
				25
				30
				35
				40
				50
40	50	65	5	20
				25
				30
				40
				50
45	55	70	5	30
				35
				40
				50
50	60	75	5	60
				30
				35
				40
55	65	80	5	50
				60
				40

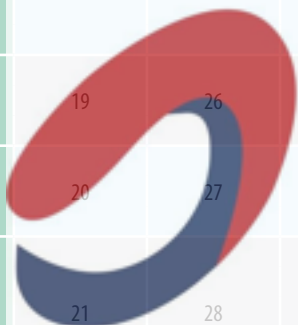

mayoral
Suministros Industriales y Servicios

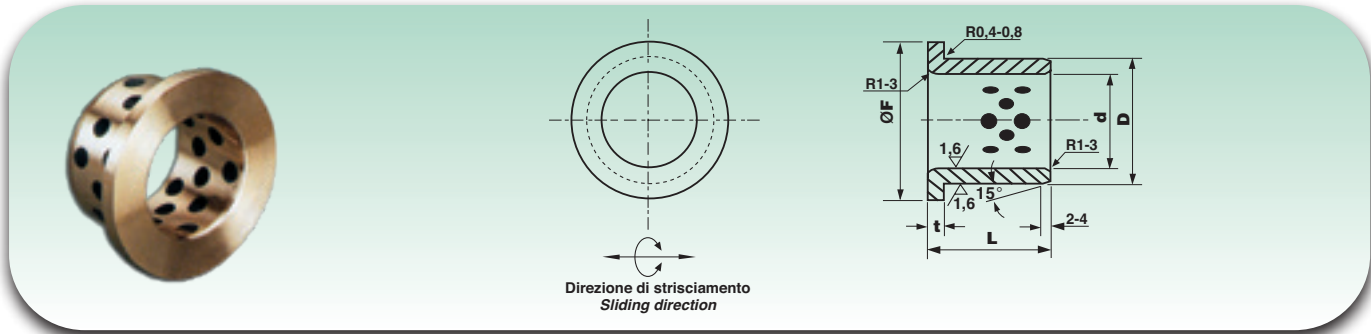

Dimensioni (mm) Dimensions (mm)				
$d_{(E7)}$	$D_{(r6)}$	F	$t \begin{smallmatrix} 0 \\ -0,1 \end{smallmatrix}$	$L \begin{smallmatrix} -0,10 \\ -0,30 \end{smallmatrix}$
55	70	80	5	40
				60
60	75	90	7,5	40
				50
				70
				80
63	75	85	7,5	67
65	80	95	7,5	40
				60
				80
70	85	105	7,5	50
				80
75	90	110	7,5	60
				80

Dimensioni (mm) Dimensions (mm)				
$d_{(E7)}$	$D_{(r6)}$	F	$t \begin{smallmatrix} 0 \\ -0,1 \end{smallmatrix}$	$L \begin{smallmatrix} -0,10 \\ -0,30 \end{smallmatrix}$
80	100	120	10	50
				60
				80
90	110	130	10	100
				50
				60
				80
100	120	150	10	60
				80
120	140	170	10	100
				60
				80

Per ordinare specificare: BG-F.. tipo 1/2/3/4/5 + d + D + L

To order, please specify: BG-F..type 1/2/3/4/5 + d + D + L



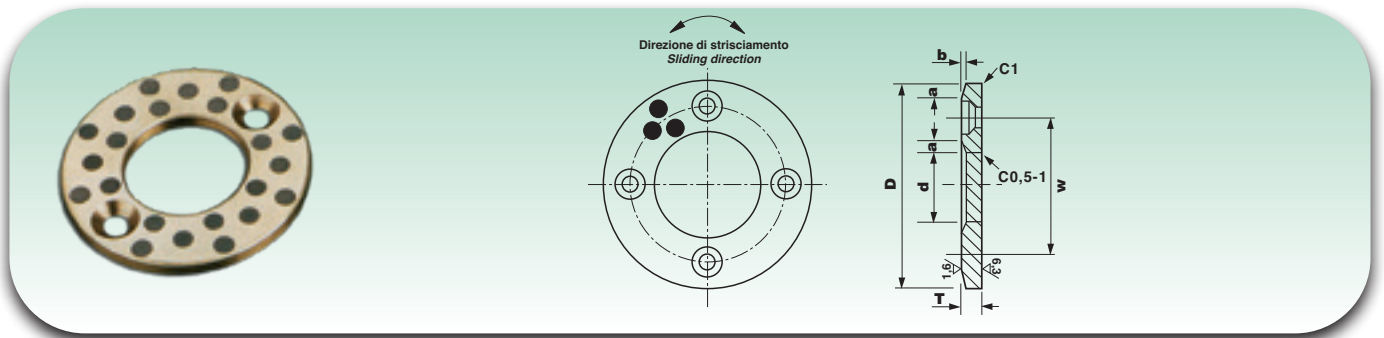

Sigla Designation	Dimensioni (mm.) Dimensions (mm.)							
	d	D	T ⁰ _{-0,1}	W	Foro - Hole		a	b
					n°	Filetto - Thread		
BG1-W 10	10,2 ^{+0,2} _{+0,1}	30	3	20	2	M3	1,5	0,3
BG1-W 10 (SF)	10,2 ^{+0,2} _{+0,1}	30	3	20	senza foro - without hole		1,5	0,3
BG1-W 12	12,2 ^{+0,2} _{+0,1}	40	3	28	2	M3	2	0,4
BG1-W 12 (SF)	12,2 ^{+0,2} _{+0,1}	40	3	28	senza foro - without hole		2	0,4
BG1-W 13	13,2 ^{+0,2} _{+0,1}	40	3	28	2	M3	2	0,4
BG1-W 14	14,2 ^{+0,2} _{+0,1}	40	3	28	2	M3	2	0,4
BG1-W 15	15,2 ^{+0,2} _{+0,1}	50	3	35	2	M3	2	0,4
BG1-W 16	16,2 ^{+0,2} _{+0,1}	50	3	35	2	M3	2	0,4
BG1-W 16 (SF)	16,2 ^{+0,2} _{+0,1}	50	3	35	senza foro - without hole		2	0,4
BG1-W 18	18,2 ^{+0,2} _{+0,1}	50	3	35	2	M3	2	0,4
BG1-W 20	20,2 ^{+0,2} _{+0,1}	50	5	35	2	M5	2,5	0,4
BG1-W 20 (SF)	20,2 ^{+0,2} _{+0,1}	50	5	35	senza foro - without hole		2,5	0,4
BG1-W 25	25,2 ^{+0,2} _{+0,1}	55	5	40	2	M5	2,5	0,4
BG1-W 25 (SF)	25,2 ^{+0,2} _{+0,1}	55	5	40	senza foro - without hole		2,5	0,4
BG1-W 30	30,2 ^{+0,2} _{+0,1}	60	5	45	2	M5	2,5	0,4
BG1-W 35	35,2 ^{+0,2} _{+0,1}	70	5	50	2	M5	2,5	0,4
BG1-W 40	40,2 ^{+0,2} _{+0,1}	80	7	60	2	M6	3	0,5
BG1-W 45	45,3 ^{+0,2} _{+0,1}	90	7	70	2	M6	3	0,5
BG1-W 50	50,3 ^{+0,2} _{+0,1}	100	8	75	4	M6	4	0,6
BG1-W 55	55,3 ^{+0,2} _{+0,1}	110	8	85	4	M6	4	0,6
BG1-W 60	60,3 ^{+0,2} _{+0,1}	120	8	90	4	M8	5	0,8
BG1-W 65	65,3 ^{+0,2} _{+0,1}	125	8	95	4	M8	5	0,8
BG1-W 70	70,3 ^{+0,2} _{+0,1}	130	10	100	4	M8	5	0,8
BG1-W 75	75,3 ^{+0,2} _{+0,1}	140	10	110	4	M8	5	0,8
BG1-W 80	80,3 ^{+0,2} _{+0,1}	150	10	120	4	M8	5	0,8
BG1-W 90	90,5 ^{+0,2} _{+0,1}	170	10	140	4	M10	5	0,8
BG1-W 100	100,5 ^{+0,2} _{+0,1}	190	10	160	4	M10	5	0,8
BG1-W 120	120,5 ^{+0,2} _{+0,1}	200	10	175	4	M10	5	0,8

Per ordinare specificare: sigla + tipo 1/2/3/4/5

To order, please specify: designation + type 1/2/3/4/5

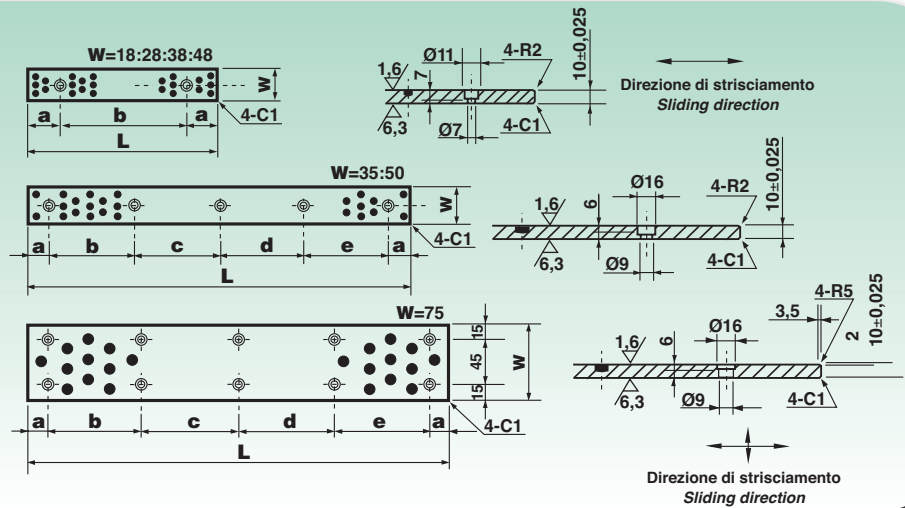
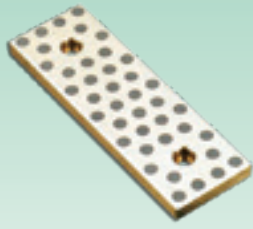

Sigla Designation	Dimensioni (mm) Dimensions (mm)								
	W ⁰ -0,2	L	Distanza tra i fori - Distance between bolts					Foro - Bolt	
			a	b	c	d	e	n°	Filetto Thread
BG1-SP 18-75	18	75 ⁰ _{-0,2}	15	45	-	-	-	2	M6
BG1-SP 18-100		100 ⁰ _{-0,2}	50	-	-	-			
BG1-SP 18-125		125 ⁰ _{-0,2}	75	-	-	-			
BG1-SP 18-150		150 ⁰ _{-0,2}	100	-	-	-			
BG1-SP 18-160		160 ⁰ _{-0,2}	110	-	-	-			
BG1-SP 18-220		220 ⁰ _{-0,3}	50	120	-	-	-		
BG1-SP 28-75	28	75 ⁰ _{-0,2}	15	45	-	-	2	M6	
BG1-SP 28-100		100 ⁰ _{-0,2}	50	-	-	-			
BG1-SP 28-125		125 ⁰ _{-0,2}	75	-	-	-			
BG1-SP 28-150		150 ⁰ _{-0,2}	100	-	-	-			
BG1-SP 28-160		160 ⁰ _{-0,2}	110	-	-	-			
BG1-SP 28-220		220 ⁰ _{-0,3}	50	120	-	-			-
BG1-SP 35-100	35	100 ⁰ _{-0,2}	20	60	-	-	2	M8	
BG1-SP 35-150		150 ⁰ _{-0,2}		55	55	-	3		
BG1-SP 35-200		200 ⁰ _{-0,3}		70	70	70	-		4
BG1-SP 35-250		250 ⁰ _{-0,3}		70	70	70	-		4
BG1-SP 35-300		300 ⁰ _{-0,3}		65	65	65	65		5
BG1-SP 35-350		350 ⁰ _{-0,3}		80	75	75	80		5
BG1-SP 38-75	38	75 ⁰ _{-0,2}	15	45	-	-	2	M6	
BG1-SP 38-100		100 ⁰ _{-0,2}	50	-	-	-			
BG1-SP 38-125		125 ⁰ _{-0,2}	75	-	-	-			
BG1-SP 38-150		150 ⁰ _{-0,2}	100	-	-	-			
BG1-SP 38-160		160 ⁰ _{-0,2}	110	-	-	-			
BG1-SP 38-220		220 ⁰ _{-0,3}	50	120	-	-			-
BG1-SP 48-75	48	75 ⁰ _{-0,2}	15	45	-	-	2	M6	
BG1-SP 48-100		100 ⁰ _{-0,2}	50	-	-	-			
BG1-SP 48-125		125 ⁰ _{-0,2}	75	-	-	-			
BG1-SP 48-150		150 ⁰ _{-0,2}	100	-	-	-			
BG1-SP 50-100	50	100 ⁰ _{-0,2}	20	60	-	-	2	M8	
BG1-SP 50-150		150 ⁰ _{-0,2}		55	55	-	3		
BG1-SP 50-200		200 ⁰ _{-0,3}		70	70	70	-		4
BG1-SP 50-250		250 ⁰ _{-0,3}		70	70	70	-		4
BG1-SP 50-300		300 ⁰ _{-0,3}		65	65	65	65		5
BG1-SP 50-400		400 ⁰ _{-0,5}		90	90	90	90		5
BG1-SP 75-150	75	150 ⁰ _{-0,2}	20	110	-	-	4	M8	
BG1-SP 75-200		200 ⁰ _{-0,3}		80	80	-	-		6
BG1-SP 75-250		250 ⁰ _{-0,3}		105	105	-	-		6
BG1-SP 75-300		300 ⁰ _{-0,3}		85	90	85	-		8
BG1-SP 75-400		400 ⁰ _{-0,5}		120	120	120	-		8
BG1-SP 75-500		500 ⁰ _{-0,5}		115	115	115	115		10

Per ordinare specificare: sigla + tipo 1/2/3/4/5

To order, please specify: designation + type 1/2/3/4/5

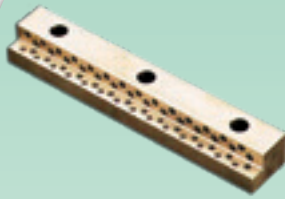

Tipo A Type

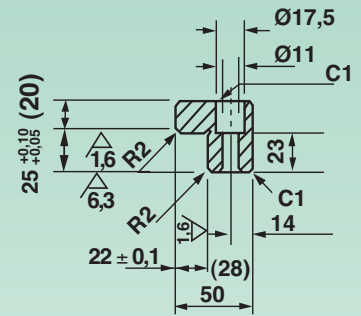
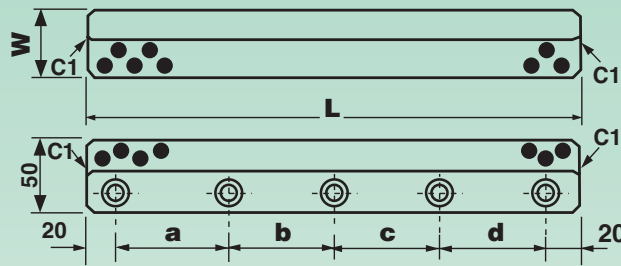

Tipo B Type

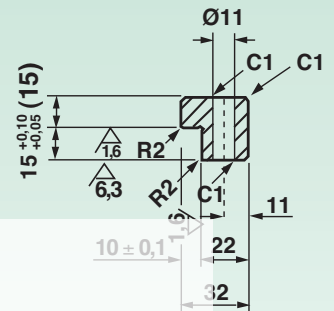
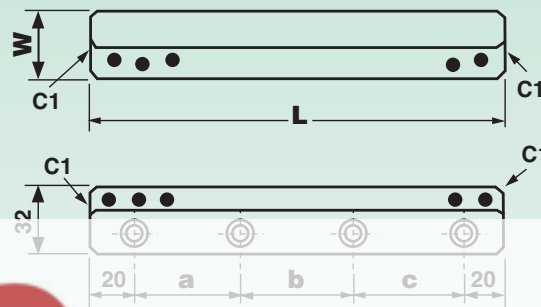

Tipo C Type

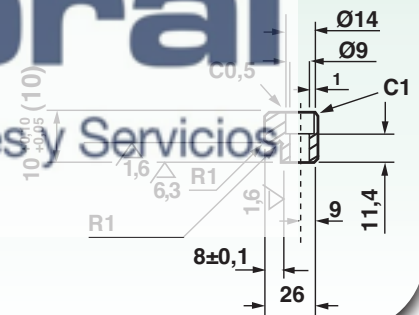
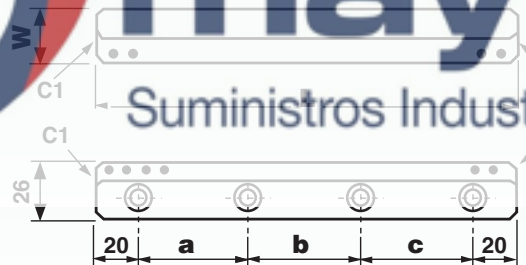

Sigla Designation	Tipo Type	Dimensioni (mm) Dimensions (mm)							
		W	L	Distanza tra i fori - Distance between bolts				Foro - Bolt	
				a	b	c	d	n°	Filetto Thread
BG1-SPL 20-100	C	20	100	60	-	-	-	2	M8
BG1-SPL 20-150			150	55	55	-	-	3	
BG1-SPL 20-200			200	55	50	55	-	4	
BG1-SPL 30-100	B	30	100	60	-	-	-	2	M10
BG1-SPL 30-150			150	55	55	-	-	3	
BG1-SPL 30-200			200	55	50	55	-	4	
BG1-SPL 30-250			250	70	70	70	-	4	
BG1-SPL 45-200	A	45	200	55	50	55	-	4	M10
BG1-SPL 45-250			250	70	70	70	-	4	
BG1-SPL 45-300			300	65	65	65	65	5	
BG1-SPL 45-350			350	80	75	75	80	5	

Per ordinare specificare: sigla + tipo 1/2/3/4/5

To order, please specify: designation + type 1/2/3/4/5

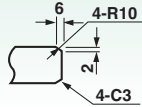
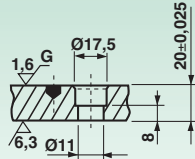
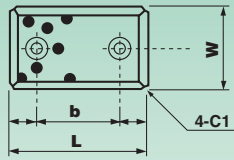
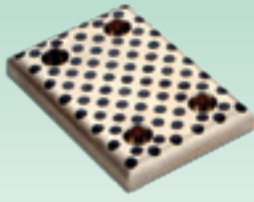

Tipo A Type

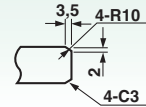
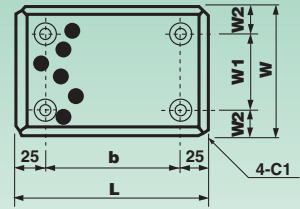

Tipo B Type

Sigla Designation	Dimensioni (mm) Dimensions (mm)						N. fori Holes n°	Tipo Type
	W ^{-0,1 -0,3}	L ^{-0,1 -0,3}	W1 ^{±0,2}	W2	b ^{±0,2}			
BG1-GP 28-75	28	75	-	-	45	2	A	
BG1-GP 28-100		100	-	-	50			
BG1-GP 28-125		125	-	-	75			
BG1-GP 28-150		150	-	-	100			
BG1-GP 28-200		200	-	-	150			
BG1-GP 38-75	38	75	-	-	45	2	A	
BG1-GP 38-100		100	-	-	50			
BG1-GP 38-125		125	-	-	75			
BG1-GP 38-150		150	-	-	100			
BG1-GP 38-200		200	-	-	150			
BG1-GP 48-75	48	75	-	-	45	2	A	
BG1-GP 48-100		100	-	-	50			
BG1-GP 48-125		125	-	-	75			
BG1-GP 48-150		150	-	-	100			
BG1-GP 48-200		200	-	-	150			
BG1-GP 58-75	58	75	-	-	45	2	A	
BG1-GP 58-100		100	-	-	50			
BG1-GP 58-150		150	-	-	100			
BG1-GP 75-75	75	75	-	-	25	2	A	
BG1-GP 75-100		100	-	-	50			
BG1-GP 75-125		125	-	-	75			
BG1-GP 75-150		150	-	-	100			
BG1-GP 75-200		200	-	-	150			
BG1-GP 100-100	100	100	-	-	50	4	B	
BG1-GP 100-125		125	-	-	75			
BG1-GP 100-150		150	50	25	100			
BG1-GP 100-200		200	-	-	150			
BG1-GP 100-250		250	-	-	200			
BG1-GP 125-125	125	125	-	-	75	4	B	
BG1-GP 125-150		150	50	37,50	100			
BG1-GP 125-200		200	-	-	150			
BG1-GP 125-250		250	-	-	200			
BG1-GP 150-150	150	150	-	-	100	4	B	
BG1-GP 150-200		200	100	25	150			
BG1-GP 150-250		250	-	-	200			
BG1-GP 150-300		300	-	-	250			
BG1-GP 200-200		200	200	-	-			150
BG1-GP 200-250	250		150	25	200			
BG1-GP 200-300	300		-	-	250			

Per ordinare specificare: sigla + tipo 1/2/3/4/5

To order, please specify: designation + type 1/2/3/4/5

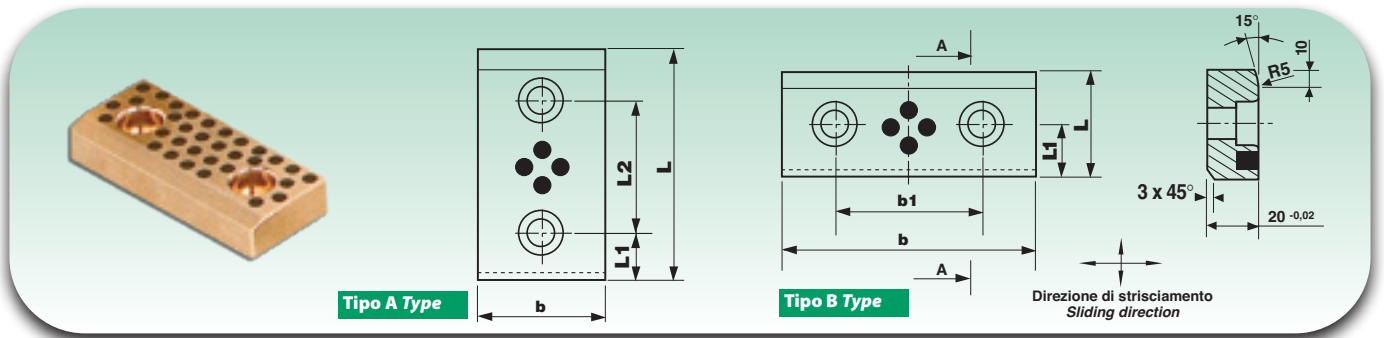

Sigla Designation	Dimensioni (mm) Dimensions (mm)					Tipo Type
	b ^{-0,2}	L ^{-0,2}	b1 ^{±0,1}	L1 ^{±0,1}	L2 ^{±0,1}	
BG1-GPS 50-80	50	80	-	25	30	A
BG1-GPS 50-100		100	-		50	
BG1-GPS 50-125		125	-		75	
BG1-GPS 50-160		160	-		110	
BG1-GPS 50-200		200	-		150	
BG1-GPS 80-50	80	50	30	25	-	A
BG1-GPS 80-80		80	-		30	
BG1-GPS 80-100		100	-		50	
BG1-GPS 80-125		125	-		75	
BG1-GPS 80-160		160	-		110	
BG1-GPS 80-200	200	-	150			
BG1-GPS 80-250	250	-	170			
BG1-GPS 80-315	315	-	235			
BG1-GPS 100-50	100	50	50	25	-	A
BG1-GPS 100-80		80	-		40	
BG1-GPS 100-100		100	-		50	
BG1-GPS 100-125		125	-		75	
BG1-GPS 100-160		160	-		110	
BG1-GPS 100-200	200	-	150			
BG1-GPS 100-250	250	-	170			
BG1-GPS 100-315	315	-	235			
BG1-GPS 125-50	125	50	75	25	-	B
BG1-GPS 125-80		80	-	40	-	
BG1-GPS 160-50	160	50	100	25	-	B
BG1-GPS 160-80		80		-	40	

Per ordinare specificare: sigla + tipo 1/2/3/4/5

To order, please specify: designation + type 1/2/3/4/5

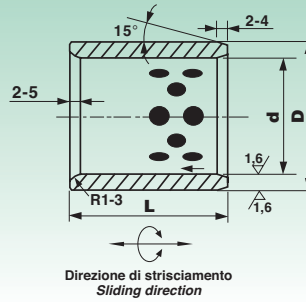

Dimensioni (mm) Dimensions (mm)		
$d_{(F7)}$	$D_{(m6)}$	L ^{-0,10 -0,30}
8	12	8
		10
		12
		15
		16
10	14	8
		10
		12
		15
		20
12	18	8
		10
		12
		15
		16
		19
		20
		25
		30
		13
12		
15		
16		
20		
14	20	10
		12
		15
		20
		25
		30
		30
15	21	10
		12
		15
		16
		20
		25
		30
16	20	12
		16
		20
		25
		30
		35
16	22	10
		12
		15
		16
		19
20		

Dimensioni (mm) Dimensions (mm)		
$d_{(F7)}$	$D_{(m6)}$	L ^{-0,10 -0,30}
16	22	25
		30
		35
		40
		40
17	23	15
		12
		15
		16
		20
		20
18	24	25
19	26	30
		35
		40
		15
		20
		10
		12
		15
		16
		16
20	28	20
		25
		30
		35
		40
20	30	16
		20
		25
		30
		35
		40
		45
20	32	45
22	32	12
		15
		20
		25
		25
25	30	16
		20
		25
		30
		35
		40
		40
		40
		12
		15
25	33	16
		20
		25
		30
		25
		30

Dimensioni (mm) Dimensions (mm)		
$d_{(F7)}$	$D_{(m6)}$	L ^{-0,10 -0,30}
25	33	35
		40
		45
		50
		60
		12
		15
		16
		20
		20
25	35	25
25	35	30
		35
		40
		45
		50
		20
		25
		30
		40
		40
30	35	16
		20
		25
		30
		30
30	36	35
		40
		50
		20
		25
		30
		35
30	38	40
		45
		50
		60
		12
		15
		20
30	40	25
		30
		35
		40
		45
		50
12		
15		
20		



mayoral
Suministros Industriales y Servicios

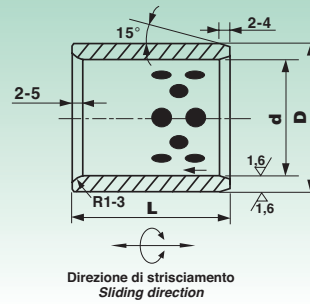

Dimensioni (mm) Dimensions (mm)		
$d_{(F7)}$	$D_{(m6)}$	L ^{-0,10 -0,30}
30	40	30
		35
		40
		45
		50
31,5	40	60
		30
31,5	42	40
		20
32	42	30
		40
		20
35	44	20
		25
		30
		35
		40
		45
		50
		60
		20
		25
35	45	30
		35
		40
		45
		50
		60
38	48	30
		40
40	50	15
		20
		25
		30
		35
		40
		45
		50
		60
		70
40	55	80
		15
		25
		30
		35
		40
		45
50		
60		

Dimensioni (mm) Dimensions (mm)		
$d_{(F7)}$	$D_{(m6)}$	L ^{-0,10 -0,30}
45	55	30
		35
		40
		45
		50
45	56	60
		30
		35
		40
		45
50	60	50
		60
		70
		80
		30
		35
		40
		45
		50
		60
50	62	70
		80
		30
		35
		40
		45
50	65	50
		60
		70
		80
		100
		30
		35
55	70	40
		30
		35

Dimensioni (mm) Dimensions (mm)		
$d_{(F7)}$	$D_{(m6)}$	L ^{-0,10 -0,30}
55	70	45
		50
		60
		70
		30
60	74	35
		40
		45
		50
		60
60	75	70
		80
		30
		35
		40
		45
		50
		60
		70
		80
63	75	100
		30
		35
		40
		50
		60
63	76	70
		80
		60
		70
65	80	80
		40
		50
		60
		70
		80
		30
70	85	35
		40
		45
		50
		60
		70
		80
70	90	100
		50
		60
		70
75	90	80
		50

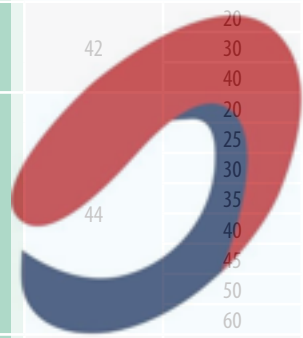

mayoral
Suministros Industriales y Servicios

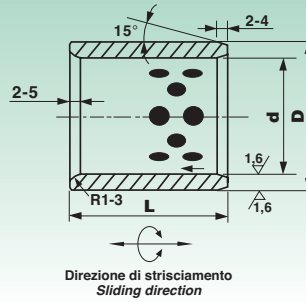

Dimensioni (mm) Dimensions (mm)				
$d_{(F7)}$	$D_{(m6)}$	L ^{-0,10 -0,30}		
75	90	60		
		70		
		80		
		100		
75	95	60		
		70		
		80		
80	96	100		
		35		
		40		
		45		
		50		
		60		
		70		
		80		
		100		
		120		
		80	100	40
				45
50				
60				
70				
80				
100				
140				

Dimensioni (mm) Dimensions (mm)		
$d_{(F7)}$	$D_{(m6)}$	L ^{-0,10 -0,30}
85	100	60
		80
90	100	30
		40
		45
		50
		60
		70
		80
		100
		120
		140
90	110	60
		70
		80
		100
		120
		140
100	110	65
		50
		70
		80
100	120	90
		100
		120
		140
		140

Dimensioni (mm) Dimensions (mm)		
$d_{(F7)}$	$D_{(m6)}$	L ^{-0,10 -0,30}
110	130	50
		70
		80
		100
		120
120	140	70
		80
		90
120	140	100
		120
		140
		140
125	145	100
		120
130	150	80
		100
		130
140	160	100
		140
140	170	80
		100
		150
160	180	80
		100
		150
		-

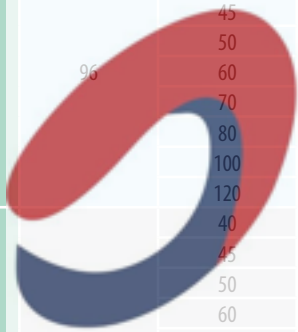

mayoral
Suministros Industriales y Servicios

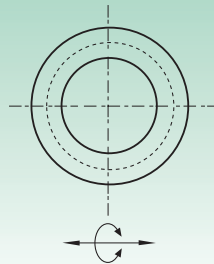

Direzione di strisciamento
Sliding direction

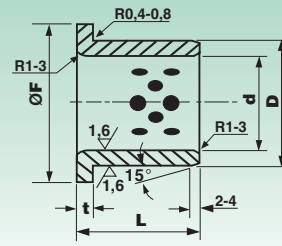

Dimensioni (mm) Dimensions (mm)				
$d_{(E7)}$	$D_{(r6)}$	F	$t_{-0,1}^0$	$L_{-0,30}^{-0,10}$
8	12	20	2	10
				15
				10
				12
10	14	22	2	15
				17
				20
				10
				15
12	18	25	3	20
				25
				30
12	18	26	3	30
				10
13	19	26	3	15
				20
				15
14	20	27	3	20
				25
				15
15	21	28	3	20
				25
				30
				15
				18
				20
16	22	29	3	23
				25
				30
				35
				40
18	24	32	3	20
				30
20	25	28	3	25
				15
				20
20	28	40	5	25
				30
				35
				15
				20
20	30	40	5	25
				30
				35
				40
				15
				20
25	33	45	5	25
				30

Dimensioni (mm) Dimensions (mm)				
$d_{(E7)}$	$D_{(r6)}$	F	$t_{-0,1}^0$	$L_{-0,30}^{-0,10}$
25	33	45	5	40
				15
				20
				25
25	35	45	5	30
				35
				40
				50
28	40	50	5	16
				20
				25
				30
30	38	50	5	35
				40
				50
				20
				25
30	40	50	5	35
				40
				50
				20
				30
31,5	40	50	5	35
				40
				20
				25
35	45	60	5	30
				35
				40
				50
				20
				25
40	50	65	5	30
				40
				50
				60
				30
				35
45	55	70	5	40
				50
				60
50	56	62	3	32
50	60	70	5	35
				30
				35
50	60	75	5	40
				50
				60
55	65	80	5	40



mayoral
Suministros Industriales y Servicios

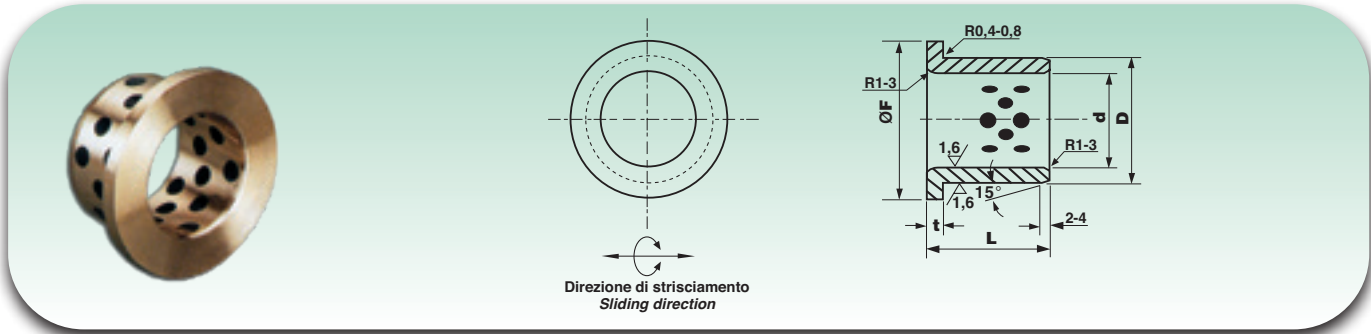

Dimensioni (mm) Dimensions (mm)				
$d_{(E7)}$	$D_{(r6)}$	F	$t \begin{smallmatrix} 0 \\ -0,1 \end{smallmatrix}$	$L \begin{smallmatrix} -0,10 \\ -0,30 \end{smallmatrix}$
55	65	80	5	60
				80
55	70	80	5	40
				60
60	75	90	7,5	40
				50
				60
				70
				80
63	75	85	7,5	67
65	80	95	7,5	40
				60
				80
70	85	105	7,5	50
				80
75	90	110	7,5	60

Dimensioni (mm) Dimensions (mm)				
$d_{(E7)}$	$D_{(r6)}$	F	$t \begin{smallmatrix} 0 \\ -0,1 \end{smallmatrix}$	$L \begin{smallmatrix} -0,10 \\ -0,30 \end{smallmatrix}$
75	90	110	7,5	80
80	100	120	10	50
				60
				80
90	110	130	10	100
				50
				60
				80
100	120	150	10	60
				80
				100
120	140	170	10	60
				80
130	150	170	15	90

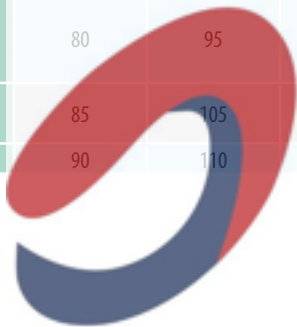

mayoral
Suministros Industriales y Servicios

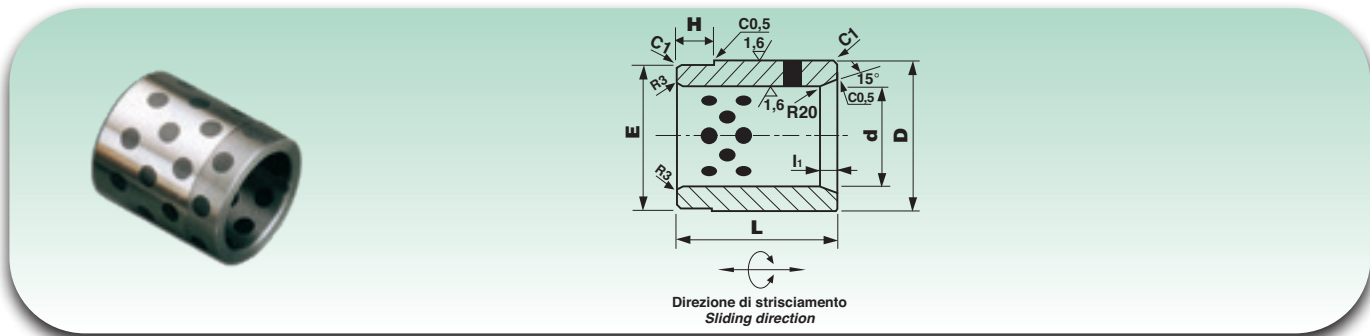

Sigla Designation	Dimensioni (mm) Dimensions (mm)					
	$d_{(H7)}$	$D_{(j6)}$	$L_{-0,20}^0$	$E_{-0,20}^0$	H	I_1
BG4 30	30	50	50	49	10	5
BG4 40	40	60	60	59	10	5
BG4 50	50	70	75	69	15	5
BG4 60	60	80	90	79	20	10
BG4 80	80	100	120	99	25	10
BG4 100	100	120	150	119	25	10
BG4 120	120	140	180	139	25	10

Per ordinare specificare: sigla + tipo 1/2/3/4/5

To order, please specify: designation + type 1/2/3/4/5



mayoral
Suministros Industriales y Servicios

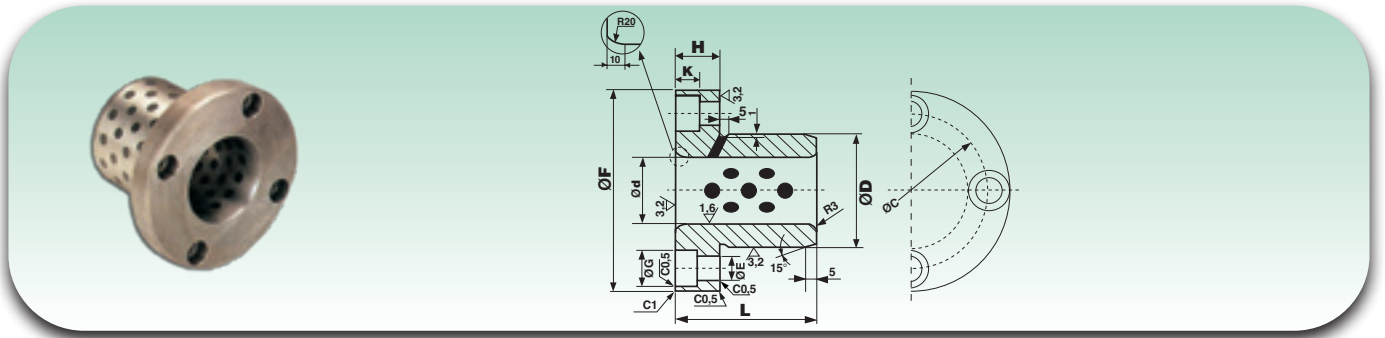

Sigla Designation	Dimensioni (mm) Dimensions (mm)								
	$d_{(H7)}$	$F^0_{-0,25}$	$D_{(j56)}$	H	$L^{\begin{matrix} -0,10 \\ -0,30 \end{matrix}}$	C	E	G	K
BG4-F 30	30	90	50	20	50	70	11	17,5	10,8
BG4-F 40	40	100	60	20	65	80	11	17,5	10,8
BG4-F 50	50	125	75	20	80	100	11	17,5	10,8
BG4-F 60	60	135	85	20	100	110	11	17,5	10,8
BG4-F 80	80	170	110	25	130	140	14	20	13
BG4-F 100	100	190	130	25	160	160	14	20	13

Per ordinare specificare: sigla + tipo 1/2/3/4/5

To order, please specify: designation + type 1/2/3/4/5



mayoral
Suministros Industriales y Servicios

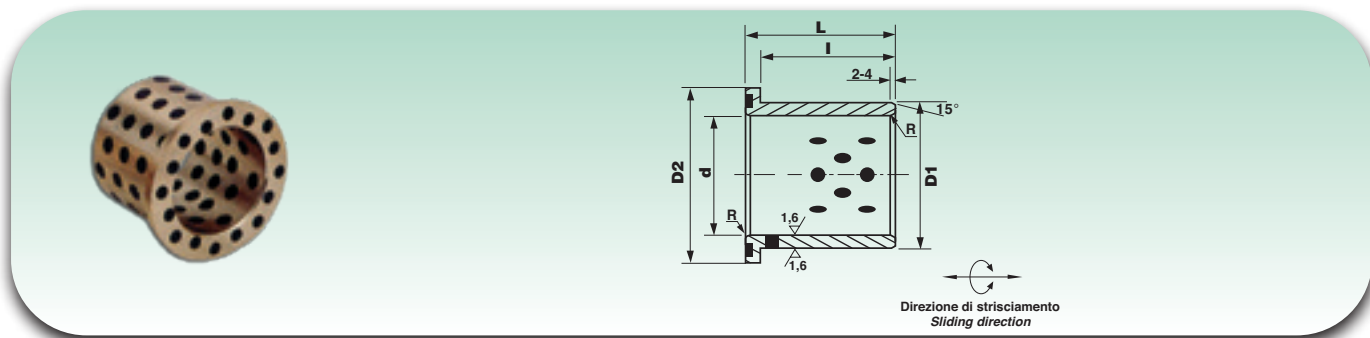

Sigla Designation	Dimensioni (mm) Dimensions (mm)				
	$d_{(F7)}$	$D1_{(m6)}$	D2	I	L
BG4-AF 12	12	18	25	11	15
BG4-AF 16	16	22	30	15	20
BG4-AF 20	20	28	36	20	25
BG4-AF 25	25	33	43	25	30
BG4-AF 30	30	38	48	30	35
BG4-AF 40	40	50	60	40	45
BG4-AF 50	50	62	75	49	55
BG4-AF 60	60	75	90	58	65

Per ordinare specificare: sigla + tipo 1/2/3/4/5

To order, please specify: designation + type 1/2/3/4/5



mayoral
Suministros Industriales y Servicios



7. Caratteristiche boccole con sfere ingabbiate BSI (allineate o a spirale)

La struttura di questa particolare boccia, può essere costruita con differenti tipologie di materiale, come ad esempio: rame, alluminio, plastica (POM).

All'interno della struttura, sono ingabbiate ed ordinate le sfere in acciaio, che possono differenziarsi per numero e per angolazione d'innesto, generando pertanto 2 tipologie di boccole con sfere ingabbiate ben distinte: allineate e a spirale.

Grazie al loro basso coefficiente d'attrito, alla lunga durata ed all'alta precisione, le boccole con sfere ingabbiate possono essere largamente impiegate nelle macchine utensili che necessitano di elevate prestazioni in termini di precisione ed in condizioni d'alta velocità assicurando pertanto sia movimenti rotatori sia verticali.

7. BSI ball retainer bushings characteristics (spiral or straight line array)

This kind of bushing can be manufactured in different types of materials such as copper, aluminium, plastic (POM).

There are steels spheres that are crated inside bushing surface according to two different arrays, that generate two quite different kind of bushings straight line or spiral.

Thanks to their low friction coefficient, long duration and high precision, the bushings with crated spheres can be widely used in tooling machines that necessitate high performance in terms of precision and in high speed conditions ensuring both rotating and vertical movements.

7.1 Caratteristiche tecniche

7.1 Technical features

Caratteristiche Characteristics	Unità di misura Measure unit
Capacità di carico Max load capacity	30 N / mm ²
Restringimento Shrink fit	0,01 mm ~ 0,02 mm
Velocità max. di scorrimento Max sliding speed	6 m / s
Coefficiente d'attrito Friction coefficient	0,01 ~ 0,08 μ
Tolleranza diametro delle sfere Tolerance for spheres diameter	< 0,002 mm

7.2 Tolleranze

7.2 Tolerances

Specificazione Specification	Materiale Material	Durezza Hardness	Tolleranza Tolerance
Struttura Structure	100 Cr6	62 ~ 66	¹⁾ 0,01 ~ 0,02 mm
Albero Shaft	100 Cr6	62 ~ 66	²⁾ h5
Sfere in acciaio Steel spheres	100 Cr6	62 ~ 66	³⁾ ±0,001

¹⁾ Quando applicato (albero + 2diametro sfere in acciaio - struttura)

²⁾ Tolleranza dell'albero

³⁾ Tolleranza diametro esterno

¹⁾ When installed (shaft + 2steel ball diameter - structure)

²⁾ Shaft tolerance

³⁾ Outside diameter tolerance

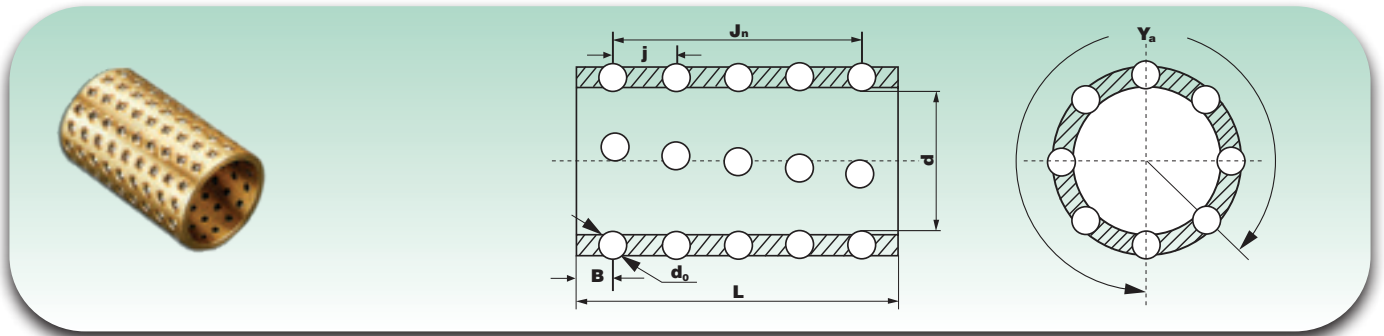

Sigla Designation	Dimensioni (mm) Dimensions (mm)							
	d	L	d _o	Y _a	J _n	n°	j	B
BSI-A 19-50	19	50	3	12	8	96	5,50	5,75
BSI-A 19-60		60			10	120	5,50	5,25
BSI-A 20-50	20	50	3	12	8	96	5,50	5,75
BSI-A 20-60		60			10	120	5,50	5,25
BSI-A 22-50	22	50	3	14	8	112	5,50	5,75
BSI-A 22-60		60			10	140	5,50	5,25
BSI-A 23-60	23	60	3	14	10	140	5,50	5,25
BSI-A 24-75	24	75	3	16	13	208	5,45	4,80
BSI-A 25-50	25	50	3	16	8	128	5,50	5,75
BSI-A 25-60		60			10	160	5,50	5,25
BSI-A 25-75		75			13	208	5,45	4,00
BSI-A 27-75	27	75	3	16	13	208	5,45	4,00
BSI-A 28-60	28	60	4	14	8	112	6,50	7,25
BSI-A 28-75		75			11	154	6,50	5,00
BSI-A 30-60	30	60	4	14	8	112	6,50	7,25
BSI-A 30-75		75			11	154	6,50	5,00
BSI-A 32-60	32	60	4	16	8	128	6,50	7,25
BSI-A 32-75		75			11	176	6,50	5,00
BSI-A 32-90		90			13	208	6,50	6,00
BSI-A 36-85	36	85	4	16	11	192	6,50	6,75
BSI-A 36-90		90			13	203	6,50	6,00
BSI-A 38-70	38	70	5	16	8	128	8,00	7,00
BSI-A 38-90		90			11	176	7,90	5,50
BSI-A 40-90	40	90	5	16	11	176	7,90	5,50
BSI-A 45-90	45	90	5	18	11	198	7,90	5,50
BSI-A 45-110		110			13	234	8,00	7,00
BSI-A 50-90	50	90	5	20	11	220	7,90	5,50
BSI-A 50-110		110			13	260	8,00	7,00
BSI-A 60-90	60	90	5	22	11	242	7,90	5,50
BSI-A 60-110		110			13	286	8,00	7,00
BSI-A 80-130	80	130	5	28	15	420	8,00	9,00

Per ordinare specificare: sigla + tipologia della struttura

To order, please specify: designation + structure type

Disponibili in rame, alluminio e plastica (POM)

Struttura in rame: CO

Struttura in alluminio: AL

Struttura in plastica (POM): PL

Copper, aluminium and plastic (POM) are available on request

Copper structure: CO

Aluminium structure: AL

Plastic structure (POM): PL

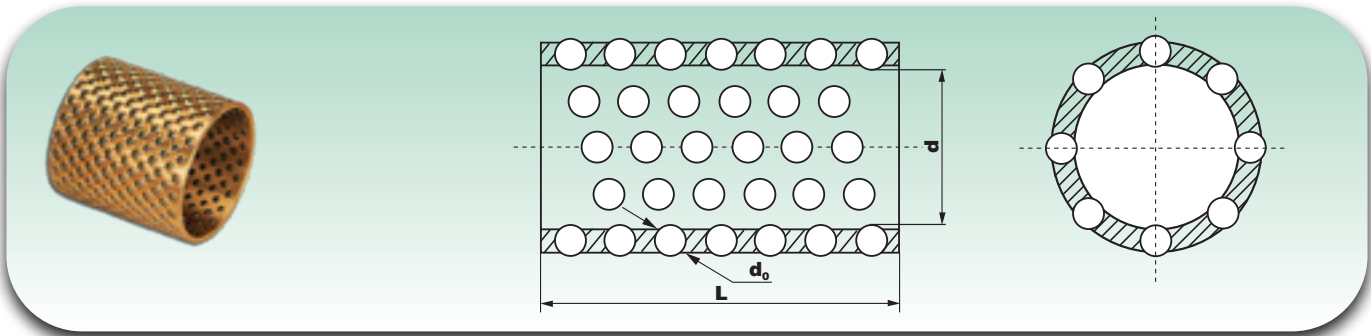

Sigla Designation	Dimensioni (mm) Dimensions (mm)					
	d	L	d _o	n°		
BSI-S 10-40	10	40	2,5	72		
BSI-S 18-43	18	43	3	74		
BSI-S 18-50		50		90		
BSI-S 18-55		55		100		
BSI-S 18-60		60		112		
BSI-S 18-64		64		120		
BSI-S 18-76		76		146		
BSI-S 19-43		19		43	3	74
BSI-S 19-50	19	50	3	90		
BSI-S 19-55		55		100		
BSI-S 19-60		60		112		
BSI-S 20-43	20	43	3	74		
BSI-S 20-50		50		90		
BSI-S 20-55		55		100		
BSI-S 20-60		60		112		
BSI-S 20-64		64		120		
BSI-S 20-75		75		144		
BSI-S 21-43		21		43	3	74
BSI-S 21-50	50		90			
BSI-S 21-55	55		100			
BSI-S 21-60	60		112			
BSI-S 21-65	65		122			
BSI-S 22-50	22		50	3		90
BSI-S 22-55			55			100
BSI-S 22-60		60	112			
BSI-S 22-64		64	120			
BSI-S 22-70		70	132			
BSI-S 23-60	23	60	3	112		
BSI-S 24-60	24	60	3	112		
BSI-S 24-65		65		122		
BSI-S 24-70		70		132		
BSI-S 24-75		75		144		
BSI-S 24-80		80		154		
BSI-S 25-48	25	48	3	86		
BSI-S 25-50		50		90		
BSI-S 25-55		55		100		
BSI-S 25-60		60		112		
BSI-S 25-64		64		120		
BSI-S 25-75		75		144		
BSI-S 25-76		76		146		
BSI-S 25-80		80		154		
BSI-S 25-85	85	164				
BSI-S 26-60	26	60	3	112		
BSI-S 26-65		65		122		
BSI-S 26-70		70		132		
BSI-S 26-80		80		154		
BSI-S 26-85		85		164		
BSI-S 27-75	27	75	3	144		

Sigla Designation	Dimensioni (mm) Dimensions (mm)			
	d	L	d _o	n°
BSI-S 28-60	28	60	4	108
BSI-S 28-64		64		118
BSI-S 28-75		75		142
BSI-S 28-76		76		144
BSI-S 28-84		84		160
BSI-S 28-90		90		174
BSI-S 30-53		30		53
BSI-S 30-60	60		108	
BSI-S 30-65	65		120	
BSI-S 30-70	30	70	4	130
BSI-S 30-75		75		140
BSI-S 30-80		80		152
BSI-S 30-85		85		162
BSI-S 31-40		31		40
BSI-S 31-50	50		88	
BSI-S 31-60	60		108	
BSI-S 31-75	75		142	
BSI-S 31-85	85		162	
BSI-S 32-50	32	50	4	88
BSI-S 32-55		55		94
BSI-S 32-60		60		108
BSI-S 32-70		70		130
BSI-S 32-75		75		140
BSI-S 32-76	32	76	4	142
BSI-S 32-84		84		160
BSI-S 32-85		85		162
BSI-S 32-90	32	90	4	174
BSI-S 32-95		95		184
BSI-S 34-70		34		70
BSI-S 34-75	75		142	
BSI-S 34-80	80		152	
BSI-S 34-90	90		174	
BSI-S 34-95	95		184	
BSI-S 35-70	35	70	4	130
BSI-S 35-76		76		144
BSI-S 35-84		84		160
BSI-S 35-90		90		174
BSI-S 35-95		95		184
BSI-S 36-80	36	80	4	152
BSI-S 36-85		85		162
BSI-S 36-90		90		174
BSI-S 37-95	37	95	5	182
BSI-S 38-68	38	68	5	124
BSI-S 38-70		70		128
BSI-S 38-75		75		138
BSI-S 38-80		80		150
BSI-S 38-85		85		160
BSI-S 38-90	38	90	5	172

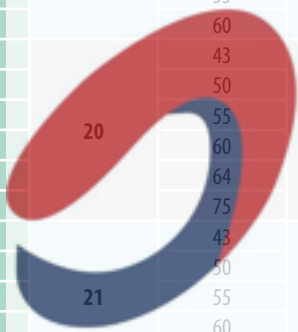

mayoral
Suministros Industriales y Servicios

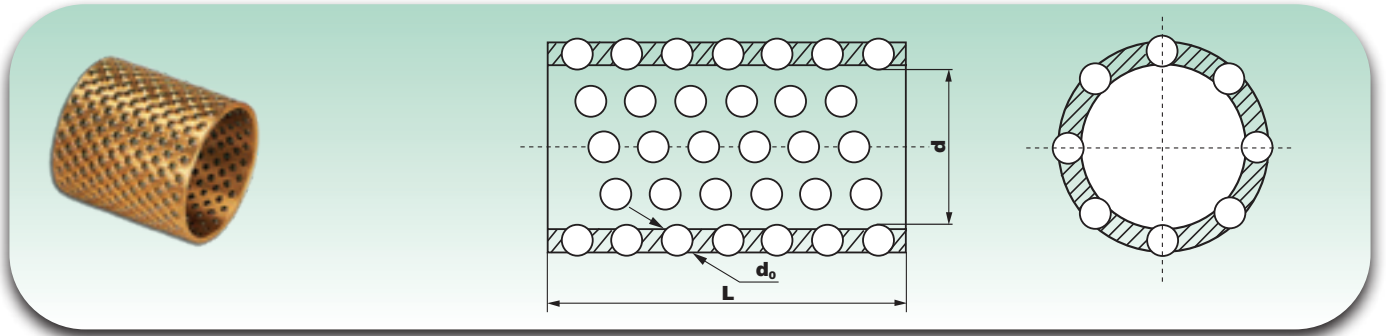

Sigla Designation	Dimensioni (mm) Dimensions (mm)			
	d	L	d ₀	n°
BSI-S 38-95	38	95	5	182
BSI-S 40-68	40	68	5	124
BSI-S 40-75		75		138
BSI-S 40-80		80		150
BSI-S 40-85		85		160
BSI-S 40-90		90		172
BSI-S 40-95		95		182
BSI-S 42-70	42	70	5	128
BSI-S 42-75		75		138
BSI-S 42-80		80		150
BSI-S 42-85		85		160
BSI-S 42-90		90		172
BSI-S 42-95		95		182
BSI-S 45-73	45	73	5	134
BSI-S 45-80		80		150
BSI-S 45-85		85		160
BSI-S 45-90		90		172
BSI-S 45-95		95		182
BSI-S 45-100		100		192
BSI-S 45-110	45	110	5	214
BSI-S 48-70		70		128
BSI-S 48-80		80		150
BSI-S 48-90		90		172
BSI-S 48-95		95		182
BSI-S 50-70		50		70
BSI-S 50-80	80		150	
BSI-S 50-90	90		172	
BSI-S 50-95	95		182	
BSI-S 50-100	100		192	
BSI-S 50-110	110		214	
BSI-S 52-70	52	70	5	128
BSI-S 52-80		80		150
BSI-S 52-90		90		172
BSI-S 52-95		95		182
BSI-S 55-80	55	80	5	150
BSI-S 55-90		90		172
BSI-S 55-100		100		192
BSI-S 56-106		56		106

Sigla Designation	Dimensioni (mm) Dimensions (mm)			
	d	L	d ₀	n°
BSI-S 58-80	58	80	5	150
BSI-S 58-90		90		172
BSI-S 58-100		100		192
BSI-S 60-80	60	80	5	150
BSI-S 60-90		90		172
BSI-S 60-100		100		192
BSI-S 60-110		110		214
BSI-S 70-90	70	90	5	170
BSI-S 70-95		95		182
BSI-S 70-100		100		192
BSI-S 70-110	70	110	5	214
BSI-S 75-90		90		172
BSI-S 75-95		95		182
BSI-S 75-100	75	100	5	192
BSI-S 75-110		110		214
BSI-S 80-90		90		172
BSI-S 80-100	80	100	5	192
BSI-S 80-110		110		214
BSI-S 80-120		120		236
BSI-S 80-130	80	130	5	258
BSI-S 85-90		90		172
BSI-S 85-100		100		192
BSI-S 85-110	85	110	5	214
BSI-S 85-120		120		236
BSI-S 90-100		100		192
BSI-S 90-110	90	110	5	214
BSI-S 90-120		120		236
BSI-S 90-130		130		258
BSI-S 90-140		140		278
BSI-S 95-120	95	120	5	236
BSI-S 100-100	100	100	5	192
BSI-S 100-110		110		214
BSI-S 100-120		120		236
BSI-S 100-130		130		258
BSI-S 100-140		140		278
BSI-S 100-150	150	290		
-	-	-	-	-



Per ordinare specificare: sigla + tipologia della struttura

To order, please specify: designation + structure type

Disponibili in rame, alluminio e plastica (POM)

Struttura in rame: **CO**
 Struttura in alluminio: **AL**
 Struttura in plastica (POM): **PL**

Copper, aluminium and plastic (POM) are available on request

Copper structure: **CO**
 Aluminium structure: **AL**
 Plastic structure (POM): **PL**

8. Programma generale di vendita ISB®

8. ISB® General sales program

Foto prodotto Product photo	Tipo ed applicazioni principali Type and main applications	Caratteristiche Characteristics
	<p>Boccole SF-1 La SF-1 è una boccola prodotta per avvolgimento, fatta di un materiale composito di tre strati, una base di acciaio, uno strato intermedio di bronzo poroso sinterizzato, ricoperto da una superficie strisciante di PTFE misto a piombo. Ha un basso coefficiente di attrito, buona resistenza all'usura ed alla corrosione, può essere usata in assenza di olio o con minima presenza di olio. In aggiunta, ha un basso costo, basse vibrazioni, bassa rumorosità, è compatta e leggera. Le SF-1 sono boccole di grandi applicazioni in organi striscianti di diversi macchinari, come quelli dell'industria tessile, del tabacco, veicoli idraulici, automobili, macchinari per l'agricoltura e le foreste</p> <p>SF-1 Bushings SF-1 is wrapped bushing made of triple layer composites material which consists of a steel backing, a sintered porous bronze particles interlayer and coated with PTFE and lead mixture as surface layer. It is of low friction coefficient, anti-wear, anti-corrosion and can be used without oil, or only a trace of oil is needed. Moreover, it is of low cost, low vibration and low noise, compact and light in weight. SF-1 is widely applied in various sliding articles of different kind of machines such as textile machines, tobacco machines, hydraulic vehicles, automobiles, agriculture and forests machines and soon.</p>	<p>Capacità di carico Load capacity 140N/mm²</p> <p>Temperatura limite Limit temperature -195 °C ~ +250 °C</p> <p>Velocità limite Speed limit 5m/s</p> <p>Coefficiente d'attrito Friction coefficient 0,04 ~ 0,18</p> <p>Limite Pv (a secco) Pv limit (dry) 2N/mm² • m/s</p> <p>Limite Pv (olio) Pv limit (oil) 50N/mm² • m/s</p>
	<p>Boccole SF-1D La boccola idraulica SF-1D è particolarmente adatta per l'uso nelle pompe a olio e dumper. È vantaggiosa quando lavora con un movimento alternativo ad alta frequenza con forze in gioco elevate. Ha buona resistenza alla fatica. È ampiamente usata in diversi cilindri idraulici, motori idraulici ed elementi pneumatici, ammortizzatori e cilindri ad olio, ecc.</p> <p>SF-1D Bushings SF-1D hydraulic bushing is particularly suitable for use in oil pump and dumper. It shows its advantages when working under high frequency reciprocating motion with a big side force. It has good anti-wear performances. It is widely used in various hydraulic cylinders, hydraulic motors, and pneumatic elements, motor damper and oil cylinders, etc.</p>	<p>Capacità di carico Load capacity 140N/mm²</p> <p>Temperatura limite Limit temperature -195 °C ~ +250 °C</p> <p>Velocità limite Speed limit 5m/s</p> <p>Coefficiente d'attrito Friction coefficient 0,04 ~ 0,20</p> <p>Limite Pv (a secco) Pv limit (dry) 3,8N/mm² • m/s</p> <p>Limite Pv (olio) Pv limit (oil) 50N/mm² • m/s</p>
	<p>Boccole SF-1SS (acciaio inox) La SF-1SS è una boccola fatta di un materiale composito di tre strati: polvere di bronzo sinterizzata su una base di acciaio inox, poi lo strato di PTFE copre lo strato di bronzo. SF-1SS può resistere a olio, acidi, basi e acqua marina. Non contiene piombo, perciò è molto usata nell'industria alimentare, flussimetri in ambienti acidi o basici per valvole e pompe, macchinari per la farmaceutica, la stampa, la chimica e l'industria marina.</p> <p>SF-1SS Bushings (stainless steel) SF-1SS bushing material is a composite of sintered bronze powder on a stainless steel base, and then the PTFE layer is coated on the bronze layer. SF-1SS can resist to oil, acids, alkali, and sea water. It is lead free, so it is popular in food machinery, acid and alkali flow meters for valves and pumps, pharmaceutical machines, printing machines, chemical machines, and other marine industry.</p>	<p>Capacità di carico Load capacity 140N/mm²</p> <p>Temperatura limite Limit temperature -150 °C ~ +150 °C</p> <p>Velocità limite Speed limit 2,5m/s</p> <p>Coefficiente d'attrito Friction coefficient 0,04 ~ 0,20</p> <p>Limite Pv (a secco) Pv limit (dry) 3,6N/mm² • m/s</p> <p>Limite Pv (olio) Pv limit (oil) 50N/mm² • m/s</p>
	<p>Boccole SF-1SSA (acciaio inox anticorrosione) Le SF-1SSA sono boccole fatte di acciaio inox anticorrosione ricoperto da PTFE sulla superficie strisciante. Hanno buone prestazioni in ambienti acidi, basici e salati, e possono essere largamente utilizzate nell'industria chimica in flussimetri per ambienti fortemente acidi/basici, pompe, valvole, ecc. Dimostra le sue prestazioni superiori nell'industria marina, dove per la superficie strisciante si richiedono caratteristiche anti-corrosive.</p> <p>SF-1SSA Bushings (anti-corrosion stainless steel) SF-1SSA is stainless steel bushings coated with PTFE: it is made by stainless steel, with spray-painted PTFE on the sliding surface. It has good performance in acid, alkali and salty liquids, and can be widely used in chemical industry such as in strong acid/alkali flow meters, pumps, valves, etc. It shows its superior performances when anti-corrosion at the sliding part is necessary in marine industry.</p>	<p>Capacità di carico Load capacity 100N/mm²</p> <p>Temperatura limite Limit temperature -150 °C ~ +150 °C</p> <p>Velocità limite Speed limit 2,5m/s</p> <p>Coefficiente d'attrito Friction coefficient 0,03 ~ 0,18</p> <p>Limite Pv (a secco) Pv limit (dry) 3,0N/mm² • m/s</p> <p>Limite Pv (olio) Pv limit (oil) 40N/mm² • m/s</p>
	<p>Boccole SF-2 La boccola SF2 per condizioni di lubrificazione limite è fatta di un materiale composito costituito da tre strati ben attaccati: una base di acciaio, uno strato intermedio di polvere di bronzo poroso sinterizzata, ed una superficie strisciante a base di POM. Funziona bene in condizioni di bassa velocità, grosso carico e temperatura normale. È efficiente ed ha una vita utile più lunga se usata come sostituta della normale boccola in bronzo. È largamente usata nei telai delle auto, nelle macchine di forgiatura, macchinari metallurgici e minerari, macchine per costruzione, centrali elettriche, laminato, ecc.</p> <p>SF-2 Bushings SF2 boundary lubrication bushing is based on a composite material with three firmly bonded layers: steel as backing, sintered porous bronze powder as interlayer, and modified POM as sliding layer. It works well under working condition of low speed, heavy duty, and normal temperature. It is cost effective and it has longer working life when it acts as substitute of normal bronze bushings. It is widely applied in auto chassis, forging machine, metallurgical and mining equipment, construction machinery, power station, strip rolling industries, etc.</p>	<p>Capacità di carico Load capacity 70N/mm²</p> <p>Temperatura limite Limit temperature -40 °C ~ +110 °C</p> <p>Velocità limite Speed limit 2,5 m/s</p> <p>Coefficiente d'attrito Friction coefficient 0,05 ~ 0,25</p> <p>Limite Pv (a secco) Pv limit (dry) 2,8N/mm² • m/s</p> <p>Limite Pv (olio) Pv limit (oil) 22N/mm² • m/s</p>

Foto prodotto Product photo	Tipo ed applicazioni principali Type and main applications	Caratteristiche Characteristics	
	<p>Boccole sinterizzate FE La boccia in ferro sinterizzato FE è fatta da polvere di ferro, pressata in stampi in condizioni di elevata pressione, poi sinterizzata in condizioni di elevata temperatura, ed infine impregnata di olio sotto vuoto per una migliore lubrificazione. Ha buone proprietà anti-frizione se funziona con bassi carichi. Può essere variamente usata nelle parti striscianti di macchine tessili, attrezzature elettriche, ammortizzatori di automobili e motocicli. In condizioni statiche, può servire come base di allineamento per la guida ed il posizionamento.</p> <p>FE Sintered bushings FE sintered bushing is made by iron powder, mould pressed under high pressure, and then sintered under high temperature, and finally oil impregnated under vacuum for better lubrication. It has good performance of anti-friction if it works under low load. It can be widely used in sliding part of textile machines, electric tools, shock absorbers of automobiles and motorcycles. Under static condition, it can be used as base housing for guiding and fixing position.</p>	<p>Capacità di carico Load capacity</p> <p>Temperatura limite Limit temperature</p> <p>Coefficiente d'attrito Friction coefficient</p> <p>Composizione chimica Chemical composition</p>	<p>45 N/mm²</p> <p>-80 °C ~ +160 °C</p> <p>0,15 ~ 0,20</p> <p>FE</p>
	<p>Boccole sinterizzate BNZ La boccia in bronzo sinterizzato BNZ è fatta da polvere di bronzo, pressata in stampi in condizioni di elevata pressione, poi sinterizzata in condizioni di elevata temperatura, ed infine impregnata di olio sotto vuoto per una migliore lubrificazione. Può essere utilizzata in condizioni di media velocità e bassi carichi. È ampiamente usata nelle apparecchiature elettriche domestiche, attrezzature elettriche, forni e macchine per l'ingegneria chimiche, macchinari tessili, industria automobilistica, apparecchiature per l'ufficio, ecc.</p> <p>BNZ Sintered bushings BNZ sintered bushing is made by bronze powder, mould pressed under high pressure, and then sintered under high temperature, and finally oil impregnated under vacuum for better lubrication. It can be used under conditions of medium speed and low load. It is widely used in domestic electric equipments, electric tools, woven and chemical engineering machines, textile machines, automobiles industry, office equipment, etc.</p>	<p>Capacità di carico Load capacity</p> <p>Temperatura limite Limit temperature</p> <p>Coefficiente d'attrito Friction coefficient</p> <p>Composizione chimica Chemical composition</p>	<p>35 N/mm²</p> <p>-10 °C ~ +90 °C</p> <p>0,12 ~ 0,18</p> <p>CuSn10Zn2</p>
	<p>Boccole in bronzo 090 La boccia 090 è ottenuta per avvolgimento da una striscia di bronzo. Il materiale è fatto con una speciale formula che garantisce un'elevata gravità specifica, e può prevedere tasche sferiche o a diamante e gole di lubrificazione a seconda le richieste del cliente. Ha un'elevata capacità di carico e una lunga durata. È ampiamente utilizzata in macchinari di sollevamento, macchinari per costruzioni, automobili, trattori, autocarri, macchine utensili, ed in alcune applicazioni nell'industria mineraria.</p> <p>090 Bronze bushings 090 bushing is wrapped by bronze strip. The material is made of particular formulation with high specific gravity, and it is suitable for application with spherical or diamond grooves for lubrication or grooves as required by customers. It is of high load capacity and long life. It is widely used in hoisting machines, construction machines, automobiles, tractors, trucks, machine tools and some mining industry.</p>	<p>Capacità di carico Load capacity</p> <p>Temperatura limite Limit temperature</p> <p>Velocità limite Speed limit</p> <p>Durezza Hardness</p> <p>Composizione chimica Chemical composition</p> <p>Limite Pv (olio) Pv limit (oil)</p>	<p>150N/mm²</p> <p>-40 °C ~ +150 °C</p> <p>2,5m/s</p> <p>HB 90 ~ 120</p> <p>CuSn8 P0,3</p> <p>75N/mm² • m/s</p>
	<p>Boccole in bronzo 092 La boccia 092 è fatta in bronzo, ed ha fori di lubrificazione distribuiti in modo uniforme su tutta la sua superficie. Durante il montaggio, la boccia dovrebbe essere ingrassata prima che le sue estremità vengano chiuse con delle tenute. La boccia 092 ha il vantaggio di abbondante tenuta di olio, facilità di montaggio, facilità di ri-lavorazione, ecc. Può sostituire boccole fatte interamente di rame, inoltre è adatta per condizione di carico intermedie e basse velocità, inclusi convogliatori, macchine per il sollevamento, chiuse idrauliche, macchine per l'allineamento, ecc.</p> <p>092 Bronze bushings 092 bronze bushing is made of bronze with oil holes evenly distributed on it. When assemble it, the bushing should be lubricated with grease before both ends of the bushing is assembled with seals. 092 has the advantages of abundant oil storage, easy-to-assembly or easy to be machined etc. It can substitute bushings made by complete copper material, in addition, it suits for conditions of middle load and low speed including convey machine, hoisting machine, windlass, aligning machine etc.</p>	<p>Capacità di carico Load capacity</p> <p>Temperatura limite Limit temperature</p> <p>Velocità limite Speed limit</p> <p>Durezza Hardness</p> <p>Composizione chimica Chemical composition</p> <p>Limite Pv (olio) Pv limit (oil)</p>	<p>150N/mm²</p> <p>-40 °C ~ +150 °C</p> <p>2,5m/s</p> <p>HB 90 ~ 120</p> <p>CuSn8 P0,3</p> <p>60N/mm² • m/s</p>
	<p>Boccole bimetalliche BM1 La boccia bimetallica BM1 è fatta di acciaio con CuPb10Sn10 sinterizzato sulla superficie strisciante. Questa tipologia di boccia mostra la migliore prestazione tra quelle in lega di rame. È più adatta per le medie velocità e le situazioni con elevati impatti. Il suo campo di applicazione include sospensioni per autocarri con elevata massa a pieno carico, telai delle automobili, ecc.</p> <p>BM1 Bimetal bushings BM1 bimetal bushing is made of steel sintered with CuPb10Sn10 as a lining layer. This type of bushing shows its best performance among bushings made of Cu-lead alloy material in this product range. It suits most for middle speed and high impact conditions. Its application includes suspensions of heavy-duty trucks, auto chassis etc.</p>	<p>Composizione chimica Chemical composition</p> <p>Capacità di carico limite Limit load capacity</p> <p>Temperatura limite Limit temperature</p> <p>Durezza Hardness</p>	<p>CuPb10Sn10</p> <p>150N/mm²</p> <p>+260 °C</p> <p>HB 70 ~ 100</p>

Foto prodotto Product photo	Tipo ed applicazioni principali Type and main applications	Caratteristiche Characteristics	
	<p>Boccole bimetalliche BM2 La boccia bimetallica BM2 ha una base di acciaio su cui è stata sinterizzata la superficie strisciante in CuPb24Sn4. Questa tipologia ha prestazioni piuttosto buone di resistenza a fatica e ad elevati carichi. È adatta per velocità e carichi intermedi. Quando viene placcata con una speciale lega leggera e con lubrificazione ad olio può essere usata in motori a combustione interna e bielle.</p> <p>BM2 Bimetal bushings BM2 is a bimetal bushing with steel back and sintered CuPb24Sn4 as lining. This type has fairly good performances in anti-fatigue and heavy load capacity. It is suitable for middle speed and middle load. When soft alloy is plated on the bushing surface and with oil lubrication, it can be applied in high-speed internal combustion engine and connect-rod.</p>	<p>Composizione chimica Chemical composition</p> <p>Capacità di carico limite Limit load capacity</p> <p>Temperatura limite Limit temperature</p> <p>Durezza Hardness</p>	<p>CuPb24Sn4</p> <p>130N/mm²</p> <p>+200 °C</p> <p>HB 45 ~ 70</p>
	<p>Boccole bimetalliche BM3 La boccia bimetallica BM3 ha una base di acciaio su cui è stata sinterizzata la superficie strisciante in CuPb30. Grazie all'elevato contenuto di piombo, ha buone prestazioni nell'evitare il grippaggio dell'albero e nell'ovviare alla presenza di sostanze estranee. Quando viene placcata con una speciale lega leggera, può essere usata in condizioni di elevata velocità, e carichi intermedi o bassi, per esempio gusci per cuscinetti dei motori a combustione interna, bielle e bilancieri.</p> <p>BM3 Bimetal bushings BM3 is a bimetal bushing with steel as backing and sintered CuPb30 as lining layer. It has good performance in anti-seizing shaft, and covers up often substance due to the high lead composition. When soft alloy is plated on the bushing, it can be used under high speed and middle or low load, e.g. master bearing shell of internal combustion engine, connect-rod and rocker arm bushing.</p>	<p>Composizione chimica Chemical composition</p> <p>Capacità di carico limite Limit load capacity</p> <p>Temperatura limite Limit temperature</p> <p>Durezza Hardness</p>	<p>CuPb30</p> <p>120N/mm²</p> <p>+170 °C</p> <p>HB 30 ~ 45</p>
	<p>Boccole bimetalliche BM4 La BM4 è una boccia con un'alta percentuale di stagno ed alluminio. Con una base in acciaio ed una superficie strisciante in AlSn20Cu, la boccia ha buona resistenza a fatica ed alla corrosione, buona capacità di carico, buona scorrevolezza. È molto usata in condizioni di elevate velocità e bassi carichi. Può essere usata come gusci per cuscinetti dei motori a combustione interna con potenza intermedia o bassa, o gusci per cuscinetti per treni, compressori, impianti di raffreddamento. È un buon sostituto per il materiale Babbitt.</p> <p>BM4 Bimetal bushings BM4 is a bushing with high percentage of tin and aluminum. With steel as back and AlSn20Cu as lining, the bushing has fairly good performance in anti-fatigue, load capacity, anti-corrosion, and smooth sliding movement. It is widely applied under high speed and low load. It can be made into bearing shells for internal combustion engine with mid or low power or bearing shells for trains, air compressor and cooling machines. It is a good substitution for Babbitt material.</p>	<p>Composizione chimica Chemical composition</p> <p>Capacità di carico limite Limit load capacity</p> <p>Temperatura limite Limit temperature</p> <p>Durezza Hardness</p>	<p>AlSn20Cu</p> <p>100N/mm²</p> <p>+150 °C</p> <p>HB 30 ~ 40</p>
	<p>Boccole in ottone con inserti in grafite BG1 La boccia BG1 con inserti di lubrificante solido è ricavata da una fusione di ottone con inserti in grafite uniformemente distribuiti sulla sua superficie. Ha prestazioni superiori alle normali boccole in cui la lubrificazione dipende da un film d'olio. In condizione di carichi pesanti, alta temperatura, bassa velocità, corrosione o dove la lubrificazione ad olio è difficile, raddoppia le sue prestazioni sia di durezza che di resistenza alla frizione rispetto alle normali boccole. Può essere ampiamente utilizzata in macchinari per la colata continua, macchinari per l'industria mineraria, navi, turbine ad aria e idrauliche, macchine per lo stampaggio plastico.</p> <p>BG1 Brass bushings with graphite insert BG1 solid lubricant embedded bushing is made of casting brass with graphite embedded evenly in it. It has superior performances than normal bushings whose lubrication depends on oil film. Under condition of heavy duty, high temperature, slow speed, corrosion or where oil is hard to be introduced, its performance doubles that of the normal bushings both in hardness and anti-friction. It can be widely applied in continuous casting machines, mining machine, ships, air turbine, hydraulic turbines and plastic injection moulding machines.</p>	<p>Materiale Material</p> <p>Durezza Hardness</p> <p>Coefficiente d'attrito (μ) Friction coefficient (μ)</p> <p>Temperatura limite Limit temperature</p> <p>Carico limite Load limit</p> <p>Velocità limite di scorrimento Sliding velocity limit</p>	<p>CuZn25Al6Fe3Mn3</p> <p>HB 210 ~ 250</p> <p>< 0,16</p> <p>+300 °C</p> <p>100N/mm²</p> <p>a secco dry 0,4m/s con olio oil 5 m/s</p>
	<p>Boccole in bronzo con inserti in grafite BG2 La boccia BG2 è fatta in bronzo CuSn6Zn6Pb3 con inserti in grafite distribuiti uniformemente sulla sua superficie. Può lavorare con carichi leggeri, elevate temperature e velocità intermedie, per esempio in forni da panettiere, macchinari per la lavorazione della gomma, macchinari dell'industria leggera, attrezzature, ecc.</p> <p>BG2 Bronze bushings with graphite insert BG2 is made of bronze CuSn6Zn6Pb3 with graphite evenly embedded in it. It can work under low load, high temperature and middle speed, e.g. in convey way of the baking furnace, rubber machine, light industry and machine tools industry etc.</p>	<p>Materiale Material</p> <p>Durezza Hardness</p> <p>Coefficiente d'attrito (μ) Friction coefficient (μ)</p> <p>Temperatura limite Limit temperature</p> <p>Carico limite Load limit</p>	<p>CuSn6Zn6Pb3</p> <p>HB 80 ~ 120</p> <p>< 0,15</p> <p>+350 °C</p> <p>60N/mm²</p>

Foto prodotto Product photo	Tipo ed applicazioni principali Type and main applications	Caratteristiche Characteristics	
	<p>Boccole bimetalliche con inserti in grafite BG3 La boccia BG3 ha quasi le stesse prestazioni della BG2. È fatta di due tipologie di materiale, una base di acciaio con polvere sinterizzata di CuSn6Zn6Pb3 sulla superficie strisciante, ed inserti di lubrificante solido distribuito sulla sua superficie. Ha un costo inferiore della BG2 ed una più elevata resistenza a rottura; le sue estremità possono essere saldate con le parti di un macchinario. È adatta per i macchinari dell'industria metallurgica, parti di macchinari dell'industria delle costruzioni, e quando si ha difficoltà a lubrificare con olio, come nel caso di convogliatori di olio.</p> <p>BG3 Bimetal bushings with graphite insert BG3 has almost the same performance as BG2. It is made of two kinds of material, steel back sintered with CuSn6Zn6Pb3 powder as a lining, then solid lubricant is embedded evenly in it. It is cost effective and has higher crash strength comparing with BG2 type; its ends can even be welded with machine part and assemble together. It is suitable for metallurgy machine, construction machine part, and where oil is hard to be employed such as oil convey equipment.</p>	<p>Materiale Material</p> <p>Durezza Hardness</p> <p>Coefficiente d'attrito (μ) Friction coefficient (μ)</p> <p>Temperatura limite Limit temperature</p> <p>Carico limite Load limit</p>	<p>CuSn6Zn6Pb3</p> <p>HB 60 ~ 90</p> <p>< 0,14</p> <p>+300 °C</p> <p>70N/mm²</p>
	<p>Boccole in ghisa con inserti in grafite BG4 La boccia BG4 è fatta di ghisa GJL-250 con inserti di lubrificante solido. È un tipico prodotto per il risparmio dei costi. Può sostituire le bocce BG2 se l'applicazione non è troppo gravosa, come nelle presse e nei macchinari per lo stampaggio plastico.</p> <p>BG4 Cast iron bushings with graphite insert BG4 is made of casting iron GJL-250 and embedded with solid lubricant. It is a typical cost saving product. It can be substitute of BG2 if requirement in mechanical performance is not high, including guide post of mould, mould-frame of plastic injection machine etc.</p>	<p>Materiale Material</p> <p>Durezza Hardness</p> <p>Coefficiente d'attrito (μ) Friction coefficient (μ)</p> <p>Temperatura limite Limit temperature</p> <p>Carico limite Load limit</p>	<p>GJL 250</p> <p>HB 180 ~ 230</p> <p>< 0,18</p> <p>+400 °C</p> <p>60N/mm²</p>
	<p>Boccole in acciaio con inserti in grafite BG5 La boccia BG5 è fatta di acciaio rinforzato 100Cr6 con inserti di lubrificante solido. Le sue buone prestazioni, in particolar modo elevata resistenza a rottura, si dimostrano nelle parti di supporto degli organi di sollevamento, come in chiuse idrauliche e gru. Non può essere usata in acqua e in ambienti acidi o basici.</p> <p>BG5 Steel bushings with graphite insert BG5 is made of reinforced material steel 100Cr6 with solid lubricant embedded in it. Its good performance of high crash strength can be shown in supporting position of hoisting machine, e. g. support part of windlass and crane. It can not be used in water or in acid/alkali condition.</p>	<p>Materiale Material</p> <p>Durezza Hardness</p> <p>Coefficiente d'attrito (μ) Friction coefficient (μ)</p> <p>Temperatura limite Limit temperature</p> <p>Carico limite Load limit</p>	<p>100Cr6</p> <p>HRC 55 ~ 60</p> <p>< 0,17</p> <p>+350 °C</p> <p>250N/mm²</p>
	<p>Boccole con sfere ingabbiate BSI Questo tipo di boccia può avere la struttura in rame, alluminio o plastica (POM) prodotta con un trattamento speciale, sulla quale le sfere di alta qualità sono disposte secondo diverse angolature e densità. Vengono utilizzate nelle macchine perforatrici a freddo e nelle macchine utensili ad alta precisione.</p> <p>BSI Ball retainer bushings The structure of this type of bushing can be in copper, aluminium or plastic (POM) being produced through special workmanship, on which the high quality spheres are arranged orderly in certain angle and density. It is used in cold punching mould and machine tools with high precision.</p>	<p>Capacità di carico Load capacity</p> <p>Restringimento Shrink fit</p> <p>Velocità limite Speed limit</p> <p>Coefficiente d'attrito Friction coefficient</p> <p>Tolleranza diametro delle sfere Tolerance for spheres diameter</p>	<p>30N/mm²</p> <p>0,01 mm ~ 0,02 mm</p> <p>6m/s</p> <p>0,01 ~ 0,08</p> <p>< 0,002 mm</p>

9. Tabella d'intercambiabilità

9. Interchangeability table

Tipo Type	ISB [*]	INA	SKF	GGB
Boccole Bushings	SF-1B	EGB..E40	PCM..B	DU [*]
Boccole flangiate Flanged bushings	SF-1B F	EGF..E40	PCMF..B	DU [*]
Ralle Thrust washers	SF-1B WC	EGW..E40	PCMW..B	DU [*]
Nastri Strips	NSTR-S	EGS..E40	PCMS..B	DU [*]
Boccole (Misure in pollici) Bushings (Inches sizes)	SF-1B	EGBZ..E40	PCZ..B	-
Boccole flangiate (Misure in pollici) Flanged bushings (Inches sizes)	SF-1B F	-	-	-
Ralle (Misure in pollici) Thrust washers (Inches sizes)	SF-1B WC	-	-	-
Nastri (Misure in pollici) Strips (Inches sizes)	NSTR-S	-	-	-
Boccole Bushings	SF-2	EGB..E50	PCM..M	DX [*]
Ralle Thrust washers	SF-2 WC	EGW..E50	PCMW..M	DX [*]
Nastri (superficie alveolata) Strips (honey cones surface)	NSTR-1	EGF..E50	PCMS..M	DX [*]
Nastri (struttura con sovrametallo e superficie alveolata) Strips (honey cones surface with plate)	NSTR-2	-	-	-
Nastri (struttura con sovrametallo e superficie non alveolata) Strips (with plate and without honey cones surface)	NSTR-3	-	-	-
Boccole (Misure in pollici) Bushings (Inches sizes)	SF-2	-	PCZ..M	-
Ralle (Misure in pollici) Thrust washers (Inches sizes)	SF-2 WC	-	-	-
Nastri superficie alveolata (Misure in pollici) Strips honey cones surface (Inches sizes)	NSTR-I	-	-	-
Boccole sinterizzate in bronzo Sintered bronze bushings	BNZ	-	PBM	BP 25
Boccole in ferro Iron bushings	FE	-	-	-
Boccole sinterizzate in bronzo flangiate Sintered bronze flanged bushings	BNZF	-	PBMF	BP 25
Boccole in ferro flangiate Iron flanged bushings	FEF	-	-	-

Tabella d'intercambiabilità
Interchangeability table

Tipo Type	ISB®	INA	SKF	GGB
Boccole Bushings	090	-	PRM	MBZ-B09™
Boccole flangiate Flanged bushings	090F	-	PRMF	-
Ralle Thrust washers	090	-	-	-
Boccole (con fori passanti sferici) Bushings (with spherical holes)	092	-	-	LD™
Boccole bimetalliche Bimetal bushings	BM1	-	-	SY™
Boccole bimetalliche flangiate Bimetal flanged bushings	BM1 F	-	-	SY™
Ralle bimetalliche Bimetal washers	BM1 R	-	-	SY™
Nastri (rivestimento bimetallico) Strips (bimetal covering)	NSTR-BM	-	-	SY™
Boccole (bronzo e grafite) Bushings (bronze and graphite)	BG1	-	-	DB™
Boccole flangiate (bronzo e grafite) Flanged bushings (bronze and graphite)	BG1-F	-	-	DB™
Ralle (bronzo e grafite) Thrust washers (bronze and graphite)	BG1-W	-	-	DB™
Piastre scorrevoli (bronzo e grafite) Sliding plates (bronze and graphite)	BG1-SP	-	-	DB™
Piastre lineari scorrevoli (bronzo e grafite) Linear sliding plates (bronze and graphite)	BG1-SPL	-	-	-
Guide piane (bronzo e grafite) Plane guides (bronze and graphite)	BG1-GP	-	-	-
Guide piane scorrevoli (bronzo e grafite) Plane sliding guides (bronze and graphite)	BG1-GPS	-	-	-
Boccole (ghisa e grafite) Bushings (cast iron and graphite)	BG2	-	-	-
Boccole flangiate (ghisa e grafite) Flanged bushings (cast iron and graphite)	BG2-F	-	-	-
Boccole (ghisa e grafite) Bushings (cast iron and graphite)	BG4	-	-	-
Boccole flangiate (ghisa e grafite) Flanged bushings (cast iron and graphite)	BG4-F	-	-	-
Boccole flangiate (con inserti di grafite anche sulla flangia) Flanged bushings (with graphite insert on the flange)	BG4-AF	-	-	-
Boccole con sfere ingabbiate allineate Ball retainer straight line array	BSI-A	-	-	-
Boccole con sfere ingabbiate a spirale Ball retainer spiral array	BSI-S	-	-	-



10. Tabella di conversione pollici/mm

10. Inches/mm conversion table

1"=25,4 mm

Frazione Fractions	Decimali Decimals	Pollici - Inch										
		0"	1"	2"	3"	4"	5"	6"	7"	8"	9"	10"
		Millimetri - Millimetres										
0	0,000000	0,0000	25,4000	50,8000	76,2000	101,6000	127,0000	152,4000	177,8000	203,2000	228,6000	254,0000
1/64	0,015625	0,3969	25,7969	51,1969	76,5969	101,9969	127,3969	152,7969	178,1969	203,5969	228,9969	254,3969
1/32	0,031250	0,7938	26,1938	51,5938	76,9938	102,3938	127,7938	153,1938	178,5938	203,9938	229,3938	254,7938
3/64	0,046875	1,1906	26,5906	51,9906	77,3906	102,7906	128,1906	153,5906	178,9906	204,3906	229,7906	255,1906
1/16	0,062500	1,5875	26,9875	52,3875	77,7875	103,1875	128,5875	153,9875	179,3875	204,7875	230,1875	255,5875
5/64	0,078125	1,9844	27,3844	52,7844	78,1844	103,5844	128,9844	154,3844	179,7844	205,1844	230,5844	255,9844
3/32	0,093750	2,3812	27,7812	53,1812	78,5812	103,9812	129,3812	154,7812	180,1812	205,5812	230,9812	256,3812
7/64	0,109375	2,7781	28,1781	53,5781	78,9781	104,3781	129,7781	155,1781	180,5781	205,9781	231,3781	256,7781
1/8	0,125000	3,1750	28,5750	53,9750	79,3750	104,7750	130,1750	155,5750	180,9750	206,3750	231,7750	257,1750
9/64	0,140625	3,5719	28,9719	54,3719	79,7719	105,1719	130,5719	155,9719	181,3719	206,7719	232,1719	257,5719
5/32	0,156250	3,9688	29,3688	54,7688	80,1688	105,5688	130,9688	156,3688	181,7688	207,1688	232,5688	257,9688
11/64	0,171875	4,3656	29,7656	55,1656	80,5656	105,9656	131,3656	156,7656	182,1656	207,5656	232,9656	258,3656
3/16	0,187500	4,7625	30,1625	55,5625	80,9625	106,3625	131,7625	157,1625	182,5625	207,9625	233,3625	258,7625
13/64	0,203125	5,1594	30,5594	55,9594	81,3594	106,7594	132,1594	157,5594	182,9594	208,3594	233,7594	259,1594
7/32	0,218750	5,5562	30,9562	56,3562	81,7562	107,1562	132,5562	157,9562	183,3562	208,7562	234,1562	259,5562
15/64	0,234375	5,9531	31,3531	56,7531	82,1531	107,5531	132,9531	158,3531	183,7531	209,1531	234,5531	259,9531
1/4	0,250000	6,3500	31,7500	57,1500	82,5500	107,9500	133,3500	158,7500	184,1500	209,5500	234,9500	260,3500
17/64	0,265625	6,7469	32,1469	57,5469	82,9469	108,3469	133,7469	159,1469	184,5469	209,9469	235,3469	260,7469
9/32	0,281250	7,1438	32,5438	57,9438	83,3438	108,7438	134,1438	159,5438	184,9438	210,3438	235,7438	261,1438
19/64	0,296875	7,5406	32,9406	58,3406	83,7406	109,1406	134,5406	159,9406	185,3406	210,7406	236,1406	261,5406
5/16	0,312500	7,9375	33,3375	58,7375	84,1375	109,5375	134,9375	160,3375	185,7375	211,1375	236,5375	261,9375
21/64	0,328125	8,3344	33,7344	59,1344	84,5344	109,9344	135,3344	160,7344	186,1344	211,5344	236,9344	262,3344
11/8	0,343750	8,7312	34,1312	59,5312	84,9312	110,3312	135,7312	161,1312	186,5312	211,9312	237,3312	262,7312
23/64	0,359375	9,1281	34,5281	59,9281	85,3281	110,7281	136,1281	161,5281	186,9281	212,3281	237,7281	263,1281
3/8	0,375000	9,5250	34,9250	60,3250	85,7250	111,1250	136,5250	161,9250	187,3250	212,7250	238,1250	263,5250
25/64	0,390625	9,9219	35,3219	60,7219	86,1219	111,5219	136,9219	162,3219	187,7219	213,1219	238,5219	263,9219
13/32	0,406250	10,3188	35,7188	61,1188	86,5188	111,9188	137,3188	162,7188	188,1188	213,5188	238,9188	264,3188
27/64	0,421875	10,7156	36,1156	61,5156	86,9156	112,3156	137,7156	163,1156	188,5156	213,9156	239,3156	264,7156
7/16	0,437500	11,1125	36,5125	61,9125	87,3125	112,7125	138,1125	163,5125	188,9125	214,3125	239,7125	265,1125
29/64	0,453125	11,5094	36,9094	62,3094	87,7094	113,1094	138,5094	163,9094	189,3094	214,7094	240,1094	265,5094
15/32	0,468750	11,9062	37,3062	62,7062	88,1062	113,5062	138,9062	164,3062	189,7062	215,1062	240,5062	265,9062
31/64	0,484375	12,3031	37,7031	63,1031	88,5031	113,9031	139,3031	164,7031	190,1031	215,5031	240,9031	266,3031
1/2	0,500000	12,7000	38,1000	63,5000	88,9000	114,3000	139,7000	165,1000	190,5000	215,9000	241,3000	266,7000
33/64	0,515625	13,0969	38,4969	63,8969	89,2969	114,6969	140,0969	165,4969	190,8969	216,2969	241,6969	267,0969
17/32	0,531250	13,4938	38,8938	64,2938	89,6938	115,0938	140,4938	165,8938	191,2938	216,6938	242,0938	267,4938
35/64	0,546875	13,8906	39,2906	64,6906	90,0906	115,4906	140,8906	166,2906	191,6906	217,0906	242,4906	267,8906
9/16	0,562500	14,2875	39,6875	65,0875	90,4875	115,8875	141,2875	166,6875	192,0875	217,4875	242,8875	268,2875
37/64	0,578125	14,6844	40,0844	65,4844	90,8844	116,2844	141,6844	167,0844	192,4844	217,8844	243,2844	268,6844
19/32	0,593750	15,0812	40,4812	65,8812	91,2812	116,6812	142,0812	167,4812	192,8812	218,2812	243,6812	269,0812
39/64	0,609375	15,4781	40,8781	66,2781	91,6781	117,0781	142,4781	167,8781	193,2781	218,6781	244,0781	269,4781
5/8	0,625000	15,8750	41,2750	66,6750	92,0750	117,4750	142,8750	168,2750	193,6750	219,0750	244,4750	269,8750
41/64	0,640625	16,2719	41,6719	67,0719	92,4719	117,8719	143,2719	168,6719	194,0719	219,4719	244,8719	270,2719
21/32	0,656250	16,6688	42,0688	67,4688	92,8688	118,2688	143,6688	169,0688	194,4688	219,8688	245,2688	270,6688
43/64	0,671875	17,0656	42,4656	67,8656	93,2656	118,6656	144,0656	169,4656	194,8656	220,2656	245,6656	271,0656
11/16	0,687500	17,4625	42,8625	68,2625	93,6625	119,0625	144,4625	169,8625	195,2625	220,6625	246,0625	271,4625
45/64	0,703125	17,8594	43,2594	68,6594	94,0594	119,4594	144,8594	170,2594	195,6594	221,0594	246,4594	271,8594
23/32	0,718750	18,2562	43,6562	69,0562	94,4562	119,8562	145,2562	170,6562	196,0562	221,4562	246,8562	272,2562
47/64	0,734375	18,6531	44,0531	69,4531	94,8531	120,2531	145,6531	171,0531	196,4531	221,8531	247,2531	272,6531
3/4	0,750000	19,0500	44,4500	69,8500	95,2500	120,6500	146,0500	171,4500	196,8500	222,2500	247,6500	273,0500
49/64	0,765625	19,4469	44,8469	70,2469	95,6469	121,0469	146,4469	171,8469	197,2469	222,6469	248,0469	273,4469
25/32	0,781250	19,8438	45,2438	70,6438	96,0438	121,4438	146,8438	172,2438	197,6438	223,0438	248,4438	273,8438
51/64	0,796875	20,2406	45,6406	71,0406	96,4406	121,8406	147,2406	172,6406	198,0406	223,4406	248,8406	274,2406
13/16	0,812500	20,6375	46,0375	71,4375	96,8375	122,2375	147,6375	173,0375	198,4375	223,8375	249,2375	274,6375
53/64	0,828125	21,0344	46,4344	71,8344	97,2344	122,6344	148,0344	173,4344	198,8344	224,2344	249,6344	275,0344
27/32	0,843750	21,4312	46,8312	72,2312	97,6312	123,0312	148,4312	173,8312	199,2312	224,6312	250,0312	275,4312
55/64	0,859375	21,8281	47,2281	72,6281	98,0281	123,4281	148,8281	174,2281	199,6281	225,0281	250,4281	275,8281
7/8	0,875000	22,2250	47,6250	73,0250	98,4250	123,8250	149,2250	174,6250	200,0250	225,4250	250,8250	276,2250
57/64	0,890625	22,6219	48,0219	73,4219	98,8219	124,2219	149,6219	175,0219	200,4219	225,8219	251,2219	276,6219
29/32	0,906250	23,0188	48,4188	73,8188	99,2188	124,6188	150,0188	175,4188	200,8188	226,2188	251,6188	277,0188
59/64	0,921875	23,4156	48,8156	74,2156	99,6156	125,0156	150,4156	175,8156	201,2156	226,6156	252,0156	277,4156
15/16	0,937500	23,8125	49,2125	74,6125	100,0125	125,4125	150,8125	176,2125	201,6125	227,0125	252,4125	277,8125
61/64	0,953125	24,2094	49,6094	75,0094	100,4094	125,8094	151,2094	176,6094	202,0094	227,4094	252,8094	278,2094
31/32	0,968750	24,6062	50,0062	75,4062	100,8062	126,2062	151,6062	177,0062	202,4062	227,8062	253,2062	278,6062
63/64	0,984375	25,0031	50,4031	75,8031	101,2031	126,6031	152,0031	177,4031	202,8031	228,2031	253,6031	279,0031





INDUSTRIES



©Copyright 

È vietata la riproduzione anche parziale del contenuto di questo catalogo tecnico. Non si possono accettare responsabilità per eventuali errori od omissioni. Le misure, i disegni e le immagini non sono impegnativi. Le condizioni generali di vendita aggiornate sono consultabili sul nostro sito isb-industries.com

 Marchio registrato.

The reproduction, even partial, of the contained concerning this technical catalogue, is forbidden. Liability for possible errors and/or omissions are not accepted. The measurements, drawings and images are not demanding. The updated general sales conditions can be found on our website isb-industries.com

 TM Registered.



BOCCOLE
BUSHINGS



2.25 ©Copyright



679991008010A026435